



MSI 35 T

THIS OPERATOR'S MANUAL MUST BE KEPT IN THE LIFT TRUCK AND MUST BE READ AND UNDERSTOOD BY OPERATORS.

1 - OPERATING AND SAFETY INSTRUCTIONS

2 - DESCRIPTION

3 - MAINTENANCE

4 - ADAPTABLE ATTACHMENTS IN OPTION ON THE RANGE

02/07/2008	1st DATE OF ISSUE
23/03/2009	UP DATING (2-4; 2-7; 2-9; 2-11; 2-13 – 2-17; 2-22 – 2-29; 3-6 – 3-9)
03/05/2010	UP DATING (1-5 ; 1-6 ; 1-10 – 1-12 ; 1-15 ; 1-16 2-4 ; 2-7 ; 2-9 ; 2-11 ; 2-13 – 2-17 ; 2-22 – 2-29 3-3 ; 3-5 ; 3-10 ; 3-11 ; 3-18 ; 3-19 ; 3-21 – 3-23)



1 - OPERATING AND SAFETY INSTRUCTIONS

TABLE OF CONTENTS

INSTRUCTIONS TO THE COMPANY MANAGER ***1 - 4***

THE SITE	1 - 4
THE OPERATOR	1 - 4
THE LIFT TRUCK	1 - 4
A - THE LIFT TRUCK'S SUITABILITY FOR THE JOB	1 - 4
B - ADAPTATION OF THE LIFT TRUCK TO STANDARD ENVIRONMENTAL CONDITIONS	1 - 4
C - MODIFICATION OF THE LIFT TRUCK	1 - 5
THE INSTRUCTIONS	1 - 5
THE MAINTENANCE	1 - 5

INSTRUCTIONS FOR THE OPERATOR ***1 - 6***

PREAMBULE	1 - 6
GENERAL INSTRUCTIONS	1 - 6
A - OPERATOR'S MANUAL	1 - 6
B - AUTHORIZATION FOR USE IN FRANCE (or see current legislation in other countries)	1 - 6
C - MAINTENANCE	1 - 6
D - MODIFICATION OF THE LIFT TRUCK	1 - 6
E - LIFTING PEOPLE	1 - 6
OPERATING INSTRUCTIONS UNLADEN AND LADEN	1 - 8
A - BEFORE STARTING THE LIFT TRUCK	1 - 8
B - DRIVER'S OPERATING INSTRUCTIONS	1 - 8
C - ENVIRONMENT	1 - 9
D - VISIBILITY	1 - 9
E - STARTING THE LIFT TRUCK	1 - 10
F - DRIVING THE LIFT TRUCK	1 - 10
G - STOPPING THE LIFT TRUCK	1 - 11
H - DRIVING THE LIFT TRUCK ON THE PUBLIC HIGHWAY	1 - 12
INSTRUCTIONS FOR HANDLING A LOAD	1 - 13
A - CHOICE OF ATTACHMENTS	1 - 13
B - MASS OF LOAD AND CENTRE OF GRAVITY	1 - 13
C - TRANSVERSE ATTITUDE OF THE LIFT TRUCK	1 - 14
D - TAKING UP A LOAD ON THE GROUND	1 - 14
E - TAKING UP AND LAYING A HIGH LOAD ON TYRES	1 - 15

MAINTENANCE INSTRUCTIONS OF THE LIFT TRUCK ***1 - 16***

GENERAL INSTRUCTIONS	1 - 16
MAINTENANCE	1 - 16
LUBRICANT AND FUEL LEVELS	1 - 16
HYDRAULIC	1 - 16
ELECTRICITY	1 - 16
WELDING	1 - 17
WASHING THE LIFT TRUCK	1 - 17

IF THE LIFT TRUCK IS NOT TO BE USED FOR A LONG TIME ***1 - 18***

INTRODUCTION	1 - 18
PREPARING THE LIFT TRUCK	1 - 18
PROTECTING THE I.C. ENGINE	1 - 18
PROTECTING THE LIFT TRUCK	1 - 18
BRINGING THE LIFT TRUCK BACK INTO SERVICE	1 - 19

INSTRUCTIONS TO THE COMPANY MANAGER

THE SITE

- Proper management of lift truck's area of travel will reduce the risk of accidents:
 - . ground not unnecessarily uneven or obstructed,
 - . no excessive slopes,
 - . pedestrian traffic controlled, etc.

THE OPERATOR

- Only qualified, authorized personnel can use the lift truck. This authorization is given in writing by the appropriate person in the establishment with respect to the use of lift trucks and must be carried permanently by the operator.



On the basis of experience, there are a number of possible situations in which operating the lift truck is contra-indicated. Such foreseeable abnormal uses, the main ones being listed below, are strictly forbidden.

- **The foreseeable abnormal behaviour resulting from ordinary neglect, but does not result from any wish to put the machinery to any improper use.**
 - **The reflex reactions of a person in the event of a malfunction, incident, fault, etc. during operation of the lift truck.**
 - **Behaviour resulting from application of the «principle of least action» when performing a task.**
 - **For certain machines, the foreseeable behaviour of such persons as: apprentices, teenagers, handicapped persons, trainees tempted to drive a lift truck, operator tempted to operate a truck to win a bet, in competition or for their own personal experience.**
- The person in charge of the equipment must take these criteria into account when assessing whether or not a person will make a suitable driver.**

THE LIFT TRUCK

A - THE LIFT TRUCK'S SUITABILITY FOR THE JOB

- MANITOU has ensured that this lift truck is suitable for use under the standard operating conditions defined in this operator's manual, with a **STATIC TEST COEFFICIENT OF 1.33** and a **DYNAMIC TEST COEFFICIENT OF 1**, as specified in harmonised norm **EN 1726-1** for mast trucks.
- Before commissioning, the company manager must make sure that the lift truck is appropriate for the work to be done, and perform certain tests (in accordance with current legislation).

B - ADAPTATION OF THE LIFT TRUCK TO STANDARD ENVIRONMENTAL CONDITIONS

- In addition to series equipment mounted on your lift truck, many options are available, such as: road lighting, stop lights, flashing light, reverse lights, reverse buzzer alarm, front light, rear light, etc.
- The operator must take into account the operating conditions to define the lift truck's signalling and lighting equipment. Contact your dealer.
- Take into account climatic and atmospheric conditions of the site of utilisation.
 - . Protection against frost (see: 3 - MAINTENANCE: LUBRICANTS AND FUEL).
 - . Adaptation of lubricants (ask your dealer for information).
 - . I.C. engine filtration (see: 3 - MAINTENANCE: FILTERS CARTRIDGES AND BELTS).



For operation under average climatic conditions, i.e.: between -15 °C and + 35 °C, correct levels of lubricants in all the circuits are checked in production. For operation under more severe climatic conditions, before starting up, it is necessary to drain all the circuits, then ensure correct levels of lubricants using lubricants properly suited to the relevant ambient temperatures. It is the same for the cooling liquid.

- A lift truck operating in an area without fire extinguishing equipment must be equipped with an individual extinguisher. There are solutions, consult your dealer.



Your lift truck is designed for outdoor use under normal atmospheric conditions and indoor use in suitably aerated and ventilated premises. It is prohibited to use the lift truck in areas where there is a risk of fire or which are potentially explosive (e.g. Refineries, fuel or gas depots, stores of inflammable products...). For use in these areas, specific equipment is available (ask your dealer for information).

- Our trucks comply with Directive 2004/108/EC concerning electromagnetic compatibility (EMC), and with the corresponding harmonized norm EN 12895. Their proper operation is no longer guaranteed if they are used within areas in which the electromagnetic fields exceed the limit specified by that norm (10 V/m).
- Directive 2002/44/EC requires company managers to not expose their employees to excessive vibration doses. There is no recognized code of measurement for comparing the machines of different manufacturers. The actual doses received can therefore be measured only under actual operating conditions at the user's premises.
- The following are some tips for minimizing these vibration doses:
 - Select the most suitable lift truck and attachment for the intended use.
 - Adapt the seat adjustment to the operator's weight (according to lift truck model) and maintain it in good condition, as well as the cab suspension. Inflate the tires in accordance with recommendations.
 - Ensure that the operators adapt their operating speed to suit the conditions on site.
 - As far as possible, arrange the site in such a way as to provide a flat running surface and remove obstacles and harmful potholes.

C - MODIFICATION OF THE LIFT TRUCK

- For your safety and that of others, you must not change the structure and settings of the various components used in your lift truck (hydraulic pressure, calibrating limiters, I.C. engine speed, addition of extra equipment, addition of counterweight, unapproved attachments, alarm systems, etc.) yourself. In this event, the manufacturer cannot be held responsible.

THE INSTRUCTIONS

- The operator's manual must always be in good condition and kept in the place provided on the lift truck and in the language used by the operator.
- The operator's manual and any plates or stickers which are no longer legible or are damaged, must be replaced immediately.

THE MAINTENANCE

- Maintenance or repairs other than those detailed in part: 3 - MAINTENANCE must be carried out by qualified personnel (consult your dealer) and under the necessary safety conditions to maintain the health of the operator and any third party.



Your lift truck must be inspected periodically to ensure that it remains in compliance. The frequency of this inspection is defined by current legislation in the country in which the lift truck is used.

INSTRUCTIONS FOR THE OPERATOR

PREAMBULE

WHENEVER YOU SEE THIS SYMBOL IT MEANS:



WARNING ! BE CAREFUL ! YOUR SAFETY OR THE SAFETY OF THE LIFT TRUCK IS AT RISK.

! *The risk of accident while using, servicing or repairing your lift truck can be restricted if you follow the safety instructions and safety measures detailed in these instruction.*

- Only the operations and manœuvres described in these operator's manual must be performed. The manufacturer cannot predict all possible risky situations. Consequently, the safety instructions given in the operator's manual and on the lift truck itself are not exhaustive.
- At any time, as an operator, you must envisage, within reason, the possible risk to yourself, to others or to the lift truck itself when you use it.

! *Failure to respect the safety and operating instructions, or the instructions for repairing or servicing your lift truck may lead to serious, even fatal accident.*

GENERAL INSTRUCTIONS

A - OPERATOR'S MANUAL

- Read the operator's manual carefully.
- The operator's manual must always be in good condition and in the place provided for it on the lift truck.
- You must report any plates and stickers which are no longer legible or which are damaged.

B - AUTHORIZATION FOR USE IN FRANCE

(or see current legislation in other countries)

- Only qualified, authorized personnel may use the lift truck. This authorization is given in writing by the appropriate person in the company, in charge of using the lift truck, and must be permanently carried by the operator.
- The operator is not competent to authorise the driving of the lift truck by another person.

C - MAINTENANCE

- The operator must immediately advise his superior if his lift truck is not in good working order or does not comply with the safety notice.
- The operator is prohibited from carrying out any repairs or adjustments himself, unless he has been trained for this purpose. He must keep the lift truck properly cleaned if this is among his responsibilities.
- The operator must carry out daily maintenance (see: 3 - MAINTENANCE: A - DAILY OR EVERY 10 HOURS SERVICE).
- The operator must ensure tyres are adapted to the nature of the ground (see area of the contact surface of the tyres in the chapter: 2 - DESCRIPTION: FRONT AND REAR TYRES). There are optional solutions, consult your dealer.
 - . SAND tyres.
 - . LAND tyres.
 - . Snow chains.

! *Do not use the lift truck if the tyres are incorrectly inflated, damaged or excessively worn, because this could put your own safety or that of others at risk, or cause damage to the lift truck itself. The fitting of foam inflated tyres is prohibited and is not guaranteed by the manufacturer, excepting prior authorisation.*

D - MODIFICATION OF THE LIFT TRUCK

- For your safety and that of others, you must not change the structure and settings of the various components used in your lift truck (hydraulic pressure, calibrating limiters, I.C. engine speed, addition of extra equipment, addition of counterweight, unapproved attachments, alarm systems, etc.) yourself. In this event, the manufacturer cannot be held responsible.

E - LIFTING PEOPLE

- The use of working equipment and load lifting attachments to lift people is:
 - either forbidden
 - or authorized exceptionally and under certain conditions (see current regulations in the country in which the lift truck is used).

OPERATING INSTRUCTIONS UNLADEN AND LADEN

A - BEFORE STARTING THE LIFT TRUCK

- Carry out daily maintenance (see: 3 - MAINTENANCE: A - DAILY OR EVERY 10 HOURS SERVICE).
- Make sure the lights, indicators and windscreen wipers are working properly.
- Make sure the rear view mirrors are in good condition, clean and properly adjusted.
- Make sure the horn works.

B - DRIVER'S OPERATING INSTRUCTIONS

- Whatever his experience, the operator is advised to familiarize himself with the position and operation of all the controls and instruments before operating the lift truck.
- Wear clothes suited for driving the lift truck, avoid loose clothes.
- Make sure you have the appropriate protective equipment for the job to be done.
- Prolonged exposure to high noise levels may cause hearing problems. It is recommended to wear ear muffs to protect against excessive noise.
- Always face the lift truck when getting into and leaving the driving seat and use the handle(s) provided for this purpose. Do not jump out of the seat to get down.
- Always pay attention when using the lift truck. Do not listen to the radio or music using headphones or earphones.
- Never operate the lift truck when hands or feet are wet or soiled with greasy substances.
- For increased comfort, adjust the seat to your requirements and adopt the correct position in the driver's cab.



Under no circumstances must the seat be adjusted while the lift truck is moving.

- The operator must always be in his normal position in the driver's cab. It is prohibited to have arms or legs, or generally any part of the body, protruding from the driver's cab of the lift truck.
- The safety belt must be worn and adjusted to the operator's size.
- The control units must never in any event be used for any other than their intended purposes (e.g. climbing onto or down from the lift truck, portmanteau, etc.).
- If the control components are fitted with a forced operation (lever lock) device, it is forbidden to leave the cab without first putting these controls in neutral.
- It is prohibited to carry passengers either on the lift truck or in the cab.

C - ENVIRONMENT

- Comply with site safety regulations.
- If you have to use the lift truck in a dark area or at night, make sure it is equipped with working lights.
- During handling operations, make sure that no one is in the way of the lift truck and its load.
- Do not allow anybody to come near the working area of the lift truck or pass beneath an elevated load.
- When using the lift truck on a transverse slope, before lifting the mast, follow the instructions given in the paragraph: INSTRUCTIONS FOR HANDLING A LOAD: C - TRANSVERSE ATTITUDE OF THE LIFT TRUCK.
- Traveling on a longitudinal slope:
 - Drive and brake gently.



- Moving without load: Forks or attachment facing downhill.



- Moving with load: Forks or attachment facing uphill.

- Take into account the lift truck's dimensions and its load before trying to negotiate a narrow or low passageway.
- Never move onto a loading platform without having first checked:
 - That it is suitably positioned and made fast.
 - That the unit to which it is connected (wagon, lorry, etc.) will not shift.
 - That this platform is prescribed for the total weight of the lift truck to be loaded.
 - That this platform is prescribed for the size of the lift truck.
- Never move onto a foot bridge, floor or freight lift, without being certain that they are prescribed for the weight and size of the lift truck to be loaded and without having checked that they are in sound working order.
- Be careful in the area of loading bays, trenches, scaffolding, soft ground and manholes.
- Make sure the ground is stable and firm under the wheels before lifting the load.
- Make sure that the scaffolding, loading platform, pilings or ground is capable of bearing the load.
- Never stack loads on uneven ground, they may tip over.
- The load or the attachment must not be left just above a structure for long periods at a time because of the descending mast. In such a case, a constant watch must be kept and the height of the forks or the attachment readjusted if necessary.
- When working near aerial lines, ensure that the safety distance is sufficient between the working area of the lift truck and the aerial line.



You must consult your local electrical agency. You could be electrocuted or seriously injured if you operate or park the lift truck too close to power cables.



In the event of high winds, do not carry out handling work that jeopardizes the stability of the lift truck and its load, particularly if the load catches the wind badly.

D - VISIBILITY

- The safety of people within the lift truck's working area, as well as that of the lift truck itself and the operator are depend on good operator visibility of the lift truck's immediate vicinity in all situations and at all times.
- This lift truck has been designed to allow good operator visibility (direct or indirect by means of rear-view mirrors) of the immediate vicinity of the lift truck while traveling with no load and with the mast in the transport position.
- Special precautions must be taken if the size of the load restricts visibility towards the front:
 - moving in reverse,
 - site layout,
 - assisted by a person directing the maneuver (while standing outside the truck's area of travel), making sure to keep this person clearly in view at all times,
 - in any case, avoid reversing over long distances.
- If visibility of your road is inadequate, ask someone to assist by directing the maneuver (while standing outside the truck's area of travel), making sure to keep this person clearly in view at all times.
- Keep all components affecting visibility in a clean, properly adjusted state and in good working order (e.g. windscreens, windows, windscreen wipers, windscreen washers, driving and work lights, rear-view mirrors).

E - STARTING THE LIFT TRUCK

SAFETY NOTICE



The lift truck must only be started up or manoeuvred when the operator is sitting in the driver's cab, with his seat belt adjusted and fastened.

- Never try to start the lift truck by pushing or towing it. Such operation may cause severe damage to the transmission. If necessary, to tow the lift truck in an emergency, the transmission must be placed in the neutral position (see: 3 - MAINTENANCE: G - OCCASIONAL MAINTENANCE).
- If using an emergency battery for start-up, use a battery with the same characteristics and respect battery polarity when connecting it. Connect at first the positive terminals before the negative terminals.



Failure to respect polarity between batteries can cause serious damage to the electrical circuit. The electrolyte in the battery may produce an explosive gas. Avoid flames and generation of sparks close to the batteries. Never disconnect a battery while it is charging.

INSTRUCTIONS

- Check the closing and locking of the hood(s).
- For lift trucks operating on gas carburisation, open the gas bottle.
- Check that the forward/reverse selector is in neutral.
- Turn the ignition key to the position I to activate the electrical system and the preheat.
- Check the fuel level on the indicator.
- Turn the ignition key fully: the I.C. engine should then start. Release the ignition key and let the I.C. engine run at idle.
- Do not engage the starter motor for more than 15 seconds and carry out the preheating between unsuccessful attempts.
- Make sure all the signal lights on the control instrument panel are off.
- Check all control instruments when the I.C. engine is warm and at regular intervals during use, so as to quickly detect any faults and to be able to correct them without any delay.
- If an instrument does not show the correct display, stop the I.C. engine and immediately carry out the necessary operations.

F - DRIVING THE LIFT TRUCK

SAFETY NOTICE



Operators' attention is drawn to the risks involved in using the lift truck, in particular:

- Risk of losing control.
- Risk of losing lateral and frontal stability of the lift truck.

The operator must remain in control of the lift truck.

In the event of the lift truck overturning, do not try to leave the cabin during the incident. YOUR BEST PROTECTION IS TO STAY FASTENED IN THE CABIN.

- Observe the company's traffic regulations or, by default, the public highway code.
- Do not carry out operations which exceed the capacities of your lift truck or attachments.
- Always drive the lift truck with the forks or attachment to the transport position, i.e. at 300 mm from the ground and the carriage sloping backwards.
- Only carry loads which are balanced and properly anchored to avoid any risk of a load falling off.
- Ensure that palletes, cases, etc, are in good order and suitable for the load to be lifted.
- Familiarise yourself with the lift truck on the terrain where it will be used.
- Ensure that the service brakes are working properly.
- The loaded lift truck must not travel at speeds in excess of 12 km/h.
- Drive smoothly at an appropriate speed for the operating conditions (land configuration, load on the lift truck).
- Do not use the hydraulic mast controls when the lift truck is moving.
- Do not manoeuvre the lift truck with the mast in the raised position unless under exceptional circumstances and then with extreme caution, at very low speed and using gentle braking. Ensure that visibility is adequate.
- Take bends slowly.
- In all circumstances make sure you are in control of your speed.
- On damp, slippery or uneven terrain, drive slowly.
- Brake gently, never abruptly.
- Only use the lift truck's forward/reverse selector from a stationary position and never do so abruptly.
- Do not drive with your foot on the brake pedal.
- Always remember that hydrostatic type steering is extremely sensitive to movement of the steering wheel, so turn it gently and not jerkily.
- Never leave the I.C. engine on when the lift truck is unattended.
- Do not leave the cab when the lift truck has a raised load.
- Look where you are going and always make sure you have good visibility along the route.

- Use the rear-view mirrors frequently.
- Drive round obstacles.
- Never drive on the edge of a ditch or steep slope.
- It is dangerous to use two lift trucks simultaneously to handle heavy or voluminous loads, since this operation requires particular precautions to be taken. It must only be used exceptionally and after risk analysis.
- The ignition switch has an emergency stop mechanism in case of an operating anomaly occurring in the case of lift trucks not fitted with a punch-operated cut-out.

INSTRUCTIONS

- Always drive the lift truck with the forks or attachment to the transport position, i.e. at 300 mm from the ground and the carriage sloping backwards.
- For lift trucks with gearboxes, use the recommended gear (see: 2 - DESCRIPTION: INSTRUMENTS AND CONTROLS).
- Release the parking brake.
- Shift the forward/reverse selector to the selected direction of travel and accelerate gradually until the lift truck moves off.

G - STOPPING THE LIFT TRUCK

SAFETY NOTICE

- Never leave the ignition key in the lift truck during the operator's absence.
- When the lift truck is stationary, or if the operator has to leave his cab (even for a moment), place the forks or attachment on the ground, apply the parking brake and put the forward/reverse selector in neutral.
- Make sure that the lift truck is not stopped in any position that will interfere with the traffic flow and at less than one meter from the track of a railway.
- In the event of prolonged parking on a site, protect the lift truck from bad weather, particularly from frost (check the level of antifreeze), close and lock all the lift truck accesses (doors, windows, cowls...).

INSTRUCTIONS

- Park the lift truck on flat ground or on an incline lower than 15 %.
- Place the forward/reverse selector in neutral.
- Apply the parking brake.
- For lift trucks with gearboxes, place the gear lever in neutral.
- Lower the forks or attachment to rest on the ground.
- When using an attachment with a grab or jaws, or a bucket with hydraulic opening, close the attachment fully.
- Before stopping the lift truck after a long working period, leave the I.C. engine idling for a few moments, to allow the coolant liquid and oil to lower the temperature of the I.C. engine and transmission. Do not forget this precaution, in the event of frequent stops or warm stalling of the I.C. engine, or else the temperature of certain parts will rise significantly due to the stopping of the cooling system, with the risk of badly damaging such parts.
- Stop the I.C. engine with the ignition switch.
- Remove the ignition key.
- Lock all the accesses to the lift truck (doors, windows, cowls...).
- For lift trucks operating on gas carburisation, shut the LPG bottle. For a long lasting stop, let the engine stop naturally by shutting the LPG bottle before switching off the ignition, so as to eliminate all the fuel in the feed tube.

H - DRIVING THE LIFT TRUCK ON THE PUBLIC HIGHWAY

SAFETY INSTRUCTIONS

- Operators driving on the public highway must comply with current highway code legislation.
- The lift truck must comply with current road legislation. If necessary, there are optional solutions. Contact your dealer.

INSTRUCTIONS

- Make sure the revolving light is in place, switch it on and verify its operation.
- Check the good working order and cleanness of lights, indicators and windscreen wiper.
- Switch off the working headlights if the lift truck is fitted with them.
- Put the attachment at 300 mm from the ground.



Never move in neutral (forward/reverse selector or gear lever in neutral or transmission cut-off button pressed) to preserve the lift truck engine brake. Failure to respect this instruction on a slope will lead to excessive speed which may make the lift truck uncontrollable (steering, brakes) and may cause severe mechanical damage.

DRIVING THE LIFT TRUCK WITH A FRONT-MOUNTED ATTACHMENT

- You must comply with current regulations in your country, covering the possibility of driving on the public highway with a front-mounted attachment on your lift truck.
- If road legislation in your country authorizes circulation with a front-mounted attachment, you must at least:
 - Protect and report any sharp and/or dangerous edges on the attachment (see: 4 - ADAPTABLE ATTACHMENTS IN OPTION ON THE RANGE: ATTACHMENT SHIELDS).
 - The attachment must not be loaded.
 - Make sure that the attachment does not mask the lighting range of the forward lights.
 - Make sure that current legislation in your country does not require other obligations.

OPERATING THE LIFT TRUCK WITH A TRAILER

- For using a trailer, observe the regulations in force in your country (maximum travel speed, braking, maximum weight of trailer, etc.).
- Do not forget to connect the trailer's electrical equipment to that of the lift truck.
- The trailer's braking system must comply with current legislation.
- If pulling a trailer with assisted braking, the tractor lift truck must be equipped with a trailer braking mechanism. In this case, do not forget to connect the trailer braking equipment to the lift truck.
- The vertical force on the towing hook must not exceed the maximum authorised by the manufacturer (consult the manufacturer's plate on your lift truck).
- The authorised gross vehicle weight must not exceed the maximum weight authorised by the manufacturer (consult the manufacturer's plate on your lift truck).

IF NECESSARY, CONSULT YOUR DEALER.

INSTRUCTIONS FOR HANDLING A LOAD

A - CHOICE OF ATTACHMENTS

- Only attachments approved by MANITOU can be used on its lift trucks.
- Make sure the attachment is appropriate for the work to be done (see: 4 - ADAPTABLE ATTACHMENTS IN OPTION ON THE RANGE).
- Make sure the attachment is correctly installed and locked onto the lift truck carriage.
- Make sure that your lift truck attachments work properly.
- Comply with the load chart limits for the lift truck for the attachment used.
- Do not exceed the rated capacity of the attachment.
- Never lift a load in a sling without the attachment provided for the purpose. There are optional solutions ; contact your dealer.

B - MASS OF LOAD AND CENTRE OF GRAVITY

- Before taking up a load, you must know its mass and its centre of gravity.
- The load chart for your lift truck is valid for a load in which the longitudinal position of the centre of gravity is 500 or 600 mm from the base of the forks (as model of lift truck) (fig. B1). For a higher centre of gravity, contact your dealer.
- For irregular loads, determine the transverse centre of gravity before any movement (fig. B2) and set it in the longitudinal axis of the lift truck.

⚠ *It is forbidden to move a load heavier than the effective capacity defined on the lift truck load chart.*

⚠ *For loads with a moving centre of gravity (e.g. liquids), take account of the variations in the centre of gravity in order to determine the load to be handled and be vigilant and take extra care to limit these variations as far as possible.*

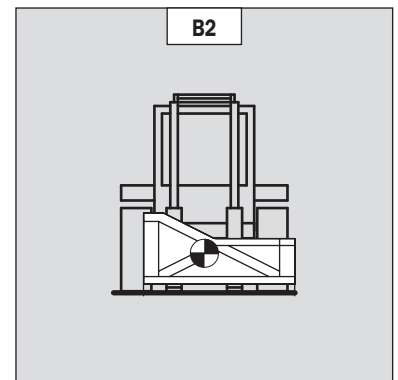
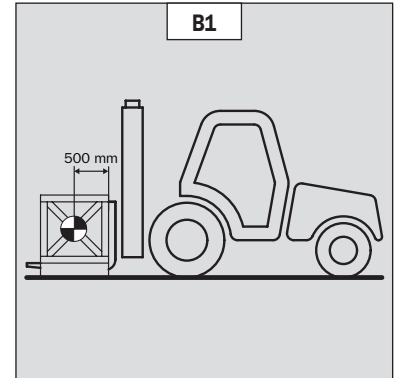

C - TRANSVERSE ATTITUDE OF THE LIFT TRUCK

The transverse attitude is the transverse slope of the chassis with respect to the horizontal.

Raising the load reduces the lift truck's lateral stability. The transverse attitude must be set with the mast in down position as follows:

- Position the lift truck so that the bubble in the level is between the two lines (see: 2 - DESCRIPTION: INSTRUMENTS AND CONTROLS).

D - TAKING UP A LOAD ON THE GROUND

- Approach the lift truck perpendicular to the load, with the forks in a horizontal position (fig. D1).
- Adjust the fork spread and centering in connection with the load (fig. D2) (optional solutions exist, consult your dealer).
- Never lift a load with a single fork.

! Beware of the risks of trapping or squashing limbs when manually adjusting the forks.

- Move the lift truck forward slowly (1) and bring the forks to stop in front of the load (fig. D3), if necessary, slightly lift the mast (2) while taking up the load.
- Bring the load into the transport position.
- Tilt the load far enough backwards to ensure stability (loss of load on braking or going downhill).

FOR A NON-PALLETIZED LOAD

- Tilt the carriage (1) forwards and move the lift truck slowly forwards (2), to insert the fork under the load (fig. D4) (block the load if necessary).
- Continue to move the lift truck forwards (2) tilting the carriage (3) (fig. D4) backwards to position the load on the forks and check the load's longitudinal and lateral stability.

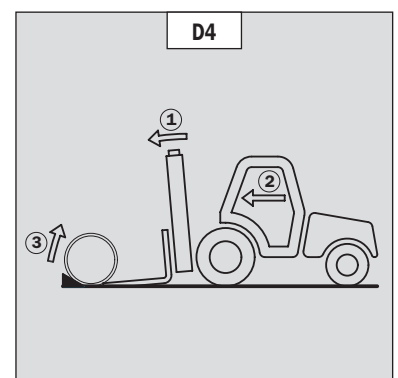
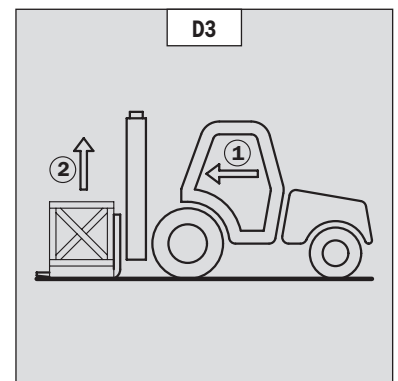
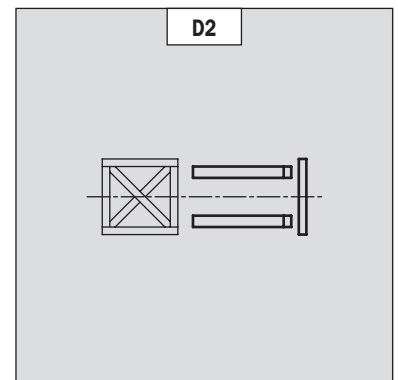
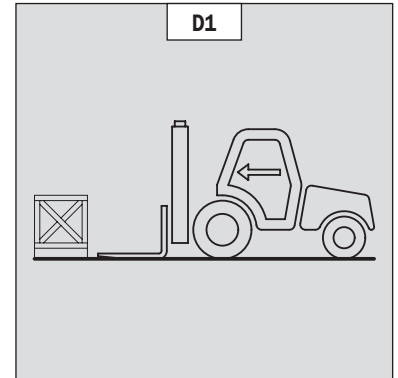

E - TAKING UP AND LAYING A HIGH LOAD ON TYRES

⚠ You must not raise the mast if you have not checked the transverse attitude of the lift truck (see: INSTRUCTIONS FOR HANDLING A LOAD: C - TRANSVERSE ATTITUDE OF THE LIFT TRUCK).

REMINDER: Make sure that the following operations can be performed with good visibility (see: OPERATIONS INSTRUCTIONS UNLADEN AND LADEN: D - VISIBILITY).

TAKING UP A HIGH LOAD ON TYRES

- Ensure that the forks will easily pass under the load.
- Keeping the mast vertical (1), advance the lift truck and raise the forks to level with the load (2) (fig. E1).
- Manoeuvre carefully and gently to bring the forks to the stop in front of the load (fig. E2). Put the handbrake on and set the forward/reverse selector to neutral.
- Slightly lift the load (1) and incline the carriage (2) backwards to stabilize the load (fig. E3).
- Tilt the load sufficiently backwards to ensure its stability.
- Reverse the lift truck (1) very carefully and gently to free the load. Lower the mast (2) to bring the load into transport position (fig. E4).

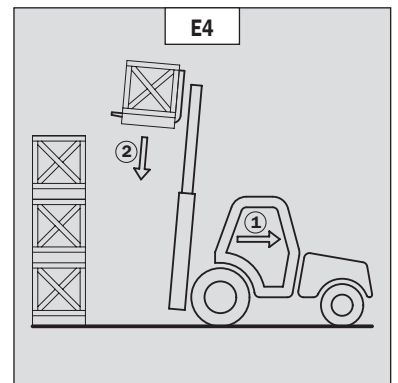
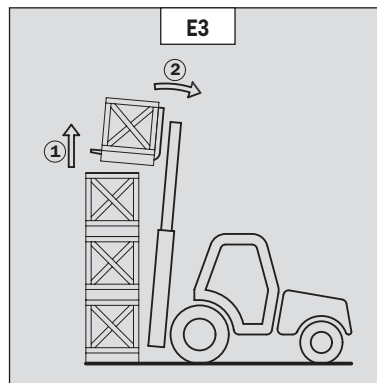
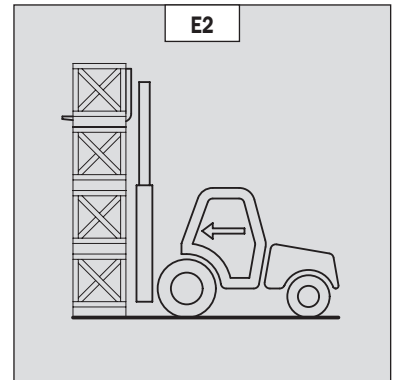
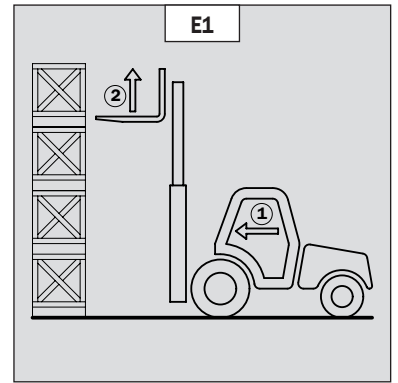

LAYING A HIGH LOAD ON TYRES

- Approach the load in the transport position in front of the pile (fig. E5).
- Raise the mast (1) until the load is higher than the pile and move the lift truck forward (2) (fig. E6) very carefully and gently, until the load is over the pile. Put the handbrake on and set the forward/reverse selector to neutral.
- Place the load in a horizontal position by tilting the mast forwards (1) and lay it down on the pile (2) while checking the correct positioning of the load (fig. E7).
- Reverse the lift truck (1) very slowly and carefully to release the forks (fig. E8). Then set them into transport position.

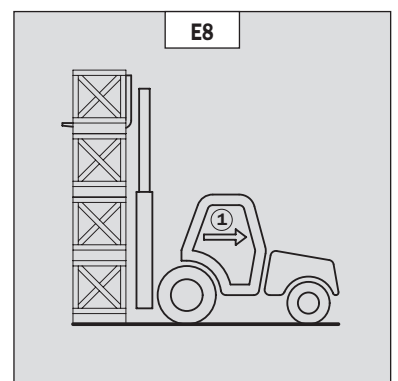
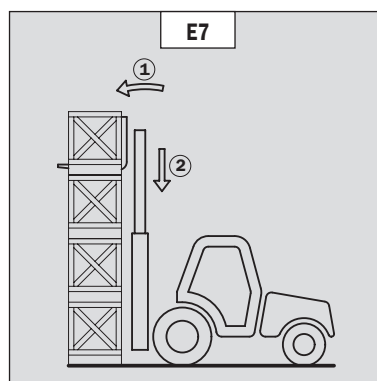
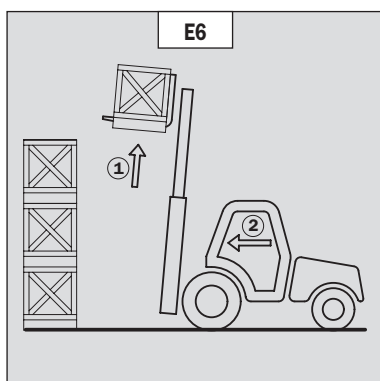
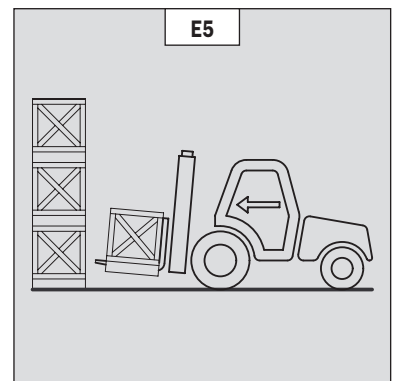

MAINTENANCE INSTRUCTIONS OF THE LIFT TRUCK

GENERAL INSTRUCTIONS

- Ensure the area is sufficiently ventilated before starting the lift truck.
- Wear clothes suitable for the maintenance of the lift truck, avoid wearing jewellery and loose clothes. Tie and protect your hair, if necessary.
- Stop the I.C. engine and remove the ignition key, when an intervention is necessary.
- Read the operator's manual carefully.
- Carry out all repairs immediately, even if the repairs concerned are minor.
- Repair all leaks immediately, even if the leak concerned is minor.
- Make sure that the disposal of process materials and of spare parts is carried out in total safety and in a ecological way.
- Be careful of the risk of burning and splashing (exhaust, radiator, I.C. engine, etc.).

MAINTENANCE

- Perform the periodic service (see: 3 - MAINTENANCE) to keep your lift truck in good working conditions. Failure to perform the periodic service may cancel the contractual guarantee.

MAINTENANCE LOGBOOK

- The maintenance operations carried out in accordance with the recommendations given in part: 3 - MAINTENANCE and the other inspection, servicing or repair operations or modifications performed on the lift truck or its attachments shall be recorded in a maintenance logbook. The entry for each operation shall include details of the date of the works, the names of the individuals or companies having performed them, the type of operation and its frequency, if applicable. The part numbers of any lift truck items replaced shall also be indicated.

LUBRICANT AND FUEL LEVELS

- Use the recommended lubricants (never use contaminated lubricants).
- Do not fill the fuel tank when the I.C. engine is running.
- Only fill up the fuel tank in areas specified for this purpose.
- Do not fill the fuel tank to the maximum level.
- Do not smoke or approach the lift truck with a flame, when the fuel tank is open or is being filled.

HYDRAULIC

- Any work on the load handling hydraulic circuit is forbidden except for the operations described in part: 3 - MAINTENANCE.
- Do not attempt to loosen unions, hoses or any hydraulic component with the circuit under pressure.

 **BALANCING VALVE: It is dangerous to change the setting and remove the balancing valves or safety valves which may be fitted to your lift truck cylinders. These operations must only be performed by approved personnel (consult your dealer).**

 **The HYDRAULIC ACCUMULATORS that may be fitted on your lift truck are pressurised units. Removing these accumulators and their pipework is a dangerous operation and must only be performed by approved personnel (consult your dealer).**

ELECTRICITY

- Do not short-circuit the starter relay to start the IC engine. If the forward/reverse selector is not in neutral and the parking brake is not engaged, the lift truck may suddenly start to move.
- Do not drop metallic items on the battery.
- Disconnect the battery before working on the electrical circuit.

WELDING

- Disconnect the battery before any welding operations on the lift truck.
- When carrying out electric welding work on the lift truck, connect the negative cable from the equipment directly to the part being welded, so as to avoid high tension current passing through the alternator.
- Never carry out welding or work which gives off heat on an assembled tyre. The heat would increase the pressure which could cause the tyre to explode.
- If the lift truck is equipped with an electronic control unit, disconnect this before starting to weld, to avoid the risk of causing irreparable damage to electronic components.

WASHING THE LIFT TRUCK

- Clean the lift truck or at least the area concerned before any intervention.
- Remember to close and lock all accesses to the lift truck (doors, windows, cowls...).
- During washing, avoid the articulations and electrical components and connections.
- If necessary, protect against penetration of water, steam or cleaning agents, components susceptible of being damaged, particularly electrical components and connections and the injection pump.
- Clean the lift truck of any fuel, oil or grease trace.

FOR ANY INTERVENTION OTHER THAN REGULAR MAINTENANCE, CONSULT YOUR DEALER.

IF THE LIFT TRUCK IS NOT TO BE USED FOR A LONG TIME

INTRODUCTION

The following recommendations are intended to prevent the lift truck from being damaged when it is withdrawn from service for an extended period.

For these operations, we recommend the use of a MANITOU protective product, reference 603726. Instructions for using the product are given on the packaging.



Procedures to follow if the lift truck is not to be used for a long time and for starting it up again afterwards must be performed by your dealership.

PREPARING THE LIFT TRUCK

- Clean the lift truck thoroughly.
- Check and repair any leakage of fuel, oil, water or air.
- Replace or repair any worn or damaged parts.
- Wash the painted surfaces of the lift truck in clear and cold water and wipe them.
- Touch up the paintwork if necessary.
- Shut down the lift truck (see: OPERATING INSTRUCTIONS UNLADEN AND LADEN).
- Make sure the mast cylinder rods are all in retracted position.
- Release the pressure in the hydraulic circuits.

PROTECTING THE I.C. ENGINE

- Fill the tank with fuel (see: 3 - MAINTENANCE: A - DAILY OR EVERY 10 HOURS SERVICE).
 - Empty and replace the cooling liquid (see: 3 - MAINTENANCE: F - EVERY 2000 HOURS SERVICE).
 - Leave the I.C. engine running at idling speed for a few minutes, then switch off.
 - Replace the I.C. engine oil and oil filter (see: 3 - MAINTENANCE: D - EVERY 500 HOURS SERVICE).
 - Add the protective product to the engine oil.
 - Run the I.C. engine for a short time so that the oil and cooling liquid circulate inside.
 - Disconnect the battery and store it in a safe place away from the cold, after charging it to a maximum.
 - Remove the injectors and spray the protective product into each cylinder for two seconds with the piston in low neutral position.
 - Turn the crankshaft once slowly and refit the injectors (see I.C. engine REPAIR MANUAL).
 - Remove the intake hose from the manifold or turbocharger and spray the protective product into the manifold or turbocharger.
 - Cap the intake manifold or turbocharger hole with waterproof adhesive tape.
 - Remove the exhaust pipe and spray the protective product into the exhaust manifold or turbocharger.
 - Refit the exhaust pipe and block the outlet with waterproof adhesive tape.
- NOTE: The spray time is noted on the product packaging and must be increased by 50 % for turbo engines.
- Open the filler plug, spray the protective product around the rocker arm shaft and refit the filler plug.
 - Cap the fuel tank using waterproof adhesive tape.
 - Remove the drive belts and store them in a safe place.
 - Disconnect the engine cut-off solenoid on the injection pump and carefully insulate the connection.

PROTECTING THE LIFT TRUCK

- Set the lift truck on axle stands so that the tyres are not in contact with the ground and release the handbrake.
- Protect cylinder rods which will not be retracted, from corrosion.
- Wrap the tyres.

NOTE: If the lift truck is to be stored outdoors, cover it with a waterproof tarpaulin.

BRINGING THE LIFT TRUCK BACK INTO SERVICE

- Remove the waterproof adhesive tape from all the holes.
- Refit the intake hose.
- Refit and reconnect the battery.
- Remove the protection from the cylinder rods.
- Perform the daily service (see: 3 - MAINTENANCE: A - DAILY OR EVERY 10 HOURS SERVICE).
- Put the handbrake on and remove the axle stands.
- Empty and replace the fuel and replace the fuel filter (see: 3 - MAINTENANCE: D - EVERY 500 HOURS SERVICE).
- Refit and set the tension in the drive belts (see: 3 - MAINTENANCE: C - EVERY 250 HOURS SERVICE).
- Turn the I.C. engine using the starter, to allow the oil pressure to rise.
- Reconnect the engine cut-off solenoid.
- Lubricate the lift truck completely (see: 3 - MAINTENANCE: SERVICING SCHEDULE).



Make sure the area is adequately ventilated before starting up the lift truck.

- Start up the lift truck, following the safety instructions and regulations (see: OPERATING INSTRUCTIONS UNLADEN AND LADEN).
- Run all the mast's hydraulic movements, concentrating on the ends of travel for each cylinder.

2 - DESCRIPTION

TABLE OF CONTENTS

« EC » DECLARATION OF CONFORMITY			2-4
IDENTIFICATION OF THE LIFT TRUCK			2-6
CHARACTERISTICS	MSI 20 T Série 2-E3	MSI 20 T BUGGIE Série 2-E3	2-8
CHARACTERISTICS	MSI 25 T Série 2-E3	MSI 25 T BUGGIE Série 2-E3	2-10
CHARACTERISTICS	MSI 30 T Série 2-E3	MSI 30 T BUGGIE Série 2-E3	2-12
CHARACTERISTICS	MSI 35 T Série 2-E3	MSI 35 T BUGGIE Série 2-E3	2-14
CHARACTERISTICS	MH 20-4 T BUGGIE Série 2-E3		2-16
CHARACTERISTICS	MH 25-4 T BUGGIE Série 2-E3		2-18
CHARACTERISTICS OF MASTS WITH ROLLERS	MSI 20 T Série 2-E3 MSI 25 T Série 2-E3	MSI 20 T BUGGIE Série 2-E3 MSI 25 T BUGGIE Série 2-E3	2-20
CHARACTERISTICS OF MASTS WITH ROLLERS	MSI 30 T Série 2-E3 MSI 35 T Série 2-E3	MSI 30 T BUGGIE Série 2-E3 MSI 35 T BUGGIE Série 2-E3	2-21
CHARACTERISTICS OF MASTS WITH ROLLERS	MH 20-4 T BUGGIE Série 2-E3	MH 25-4 T BUGGIE Série 2-E3	2-22
FRONT AND REAR TIRES			2-24
DIMENSIONS AND LOAD CHART	MSI 20 T Série 2-E3	MSI 20 T BUGGIE Série 2-E3	2-28
DIMENSIONS AND LOAD CHART	MSI 25 T Série 2-E3	MSI 25 T BUGGIE Série 2-E3	2-29
DIMENSIONS AND LOAD CHART	MSI 30 T Série 2-E3	MSI 30 T BUGGIE Série 2-E3	2-30
DIMENSIONS AND LOAD CHART	MSI 35 T Série 2-E3	MSI 35 T BUGGIE Série 2-E3	2-31
DIMENSIONS AND LOAD CHART	MH 20-4 T BUGGIE Série 2-E3		2-32
DIMENSIONS AND LOAD CHART	MH 25-4 T BUGGIE Série 2-E3		2-33
INSTRUMENTS AND CONTROLS			2-34
TOWING PIN AND HOOK			2-44
DESCRIPTION AND USE OF ELECTRIC AND HYDRAULIC OPTIONS			2-46

1) **DÉCLARATION «CE» DE CONFORMITÉ (originale)**
« EC » DECLARATION OF CONFORMITY (original)

2) La société, *The company* : **MANITOU BF**

3) Adresse, *Address* : **430, rue de l'Aubinière - BP 10249 - 44158 - ANCENIS CEDEX - FRANCE**

4) Dossier technique, *Technical file* : **MANITOU BF - 430, rue de l'Aubinière
BP 10249 - 44158 - ANCENIS CEDEX - FRANCE**

5) Constructeur de la machine décrite ci-après, *Manufacturer of the machine described below* :

MSI 20 T Série 2-E3	MSI 20 T BUGGIE Série 2-E3
MSI 25 T Série 2-E3	MSI 25 T BUGGIE Série 2-E3
MSI 30 T Série 2-E3	MSI 30 T BUGGIE Série 2-E3
MSI 35 T Série 2-E3	MSI 35 T BUGGIE Série 2-E3

MH 20-4 T BUGGIE Série 2-E3
MH 25-4 T BUGGIE Série 2-E3

6) Déclare que cette machine, *Declares that this machine* :

7) Est conforme aux directives suivantes et à leurs transpositions en droit national,
Complies with the following directives and their transpositions into national law :

2006/42/CE

8) Pour les machines annexe IV , *For annex IV machines* :

9) Numéro d'attestation, *Certificate number* :

10) Organisme notifié, *Notified body* :

15) Normes harmonisées utilisées, *Harmonised standards used* :

16) Normes ou dispositions techniques utilisées, *Standards or technical provisions used* :

17) Fait à, *Done at* : **Ancenis**

18) Date, *Date* : **29/12/2009**

19) Nom du signataire, *Name of signatory* : **Christian CALECA**

20) Fonction, *Function* : **Directeur Général Adjoint**

21) Signature, *Signature* :

bg : 1) удостоверение за « CE » съответствие (оригинална), 2) Фирмата, 3) Адрес, 4) Техническо досие, 5) Фабрикант на описаната по-долу машина, 6) Обявява, че тази машина, 7) Отговаря на следните директиви и на тяхното съответствие национално право, 8) За машините към допълнение IV, 9) Номер на удостоверението, 10) Наименувана фирма, 15) хармонизирани стандарти използвани, 16) стандарти или технически правила, използвани, 17) Изработено в, 18) Дата, 19) Име на разписалия се, 20) Функция, 21) Функция.

cs : 1) ES prohlášení o shodě (původní), 2) Název společnosti, 3) Adresa, 4) Technická dokumentace, 5) Výrobce níže uvedeného stroje, 6) Prohlašuje, že tento stroj, 7) Je v souladu s následujícími směrnici a směrnici transponovanými do vnitrostátního práva, 8) Pro stroje v příloze IV, 9) Číslo certifikátu, 10) Notifikační orgán, 15) harmonizované normy použity, 16) Norem a technických pravidel používaných, 17) Místo vydání, 18) Datum vydání, 19) Jméno podepsaného, 20) Funkce, 21) Podpis.

da : 1) EF Overensstemmelseserklæring (original), 2) Firmaet, 3) Adresse, 4) tekniske dossier, 5) Konstruktor af nedenfor beskrevne maskine, 6) Erklærer, at denne maskine, 7) Overholder nedennævnte direktiver og disses gennemførelse til national ret, 8) For maskiner under bilag IV, 9) Certifikat nummer, 10) Bemyndigede organ, 15) harmoniserede standarder, der anvendes, 16) standarder eller tekniske regler, 17) Udfærdiget i, 18) Dato, 19) Underskrivers navn, 20) Funktion, 21) Underskrift.

de : 1) EG-Konformitätserklärung (original), 2) Die Firma, 3) Adresse, 4) Technischen Unterlagen, 5) Hersteller der nachfolgend beschriebenen Maschine, 6) Erklärt, dass diese Maschine, 7) den folgenden Richtlinien und deren Umsetzung in die nationale Gesetzgebung entspricht, 8) Für die Maschinen laut Anhang IV, 9) Bescheinigungsnummer, 10) Benannte Stelle, 15) angewandten harmonisierten Normen, 16) angewandten sonstigen technischen Normen und Spezifikationen, 17) Ausgestellt in, 18) Datum, 19) Name des Unterzeichners, 20) Funktion, 21) Unterschrift.

el : 1) Δήλωση συμμόρφωσης CE (πρωτότυπο), 2) Η εταιρεία, 3) Διεύθυνση, 4) τεχνικό φάκελο, 5) Κατασκευάστρια του εξής περιγραφόμενου μηχανήματος, 6) Δηλώνει ότι αυτό το μηχάνημα, 7) Είναι σύμφωνο με τις εξής οδηγίες και τις προσαρμογές τους στο εθνικό δίκαιο, 8) Για τα μηχανήματα παραρτήματος IV, 9) Αριθμός δήλωσης, 10) Κοινοποιημένος φορέας, 15) εναρμονισμένα πρότυπα που χρησιμοποιούνται, 16) Πρότυπα ή τεχνικούς κανόνες που χρησιμοποιούνται, 16) Είναι σύμφωνο με τα εξής πρότυπα και τεχνικές διατάξεις, 17) Ev, 18) Ημερομηνία, 19) Όνομα του υπογράφοντος, 20) Θέση, 21) Υπογραφή.

es : 1) Declaración DE de conformidad (original), 2) La sociedad, 3) Dirección, 4) expediente técnico, 5) Constructor de la máquina descrita a continuación, 6) Declara que esta máquina, 7) Está conforme a las siguientes directivas y a sus transposiciones en derecho nacional, 8) Para las máquinas anexo IV, 9) Número de certificación, 10) Organismo notificado, 15) normas armonizadas utilizadas, 16) Otras normas o especificaciones técnicas utilizadas, 17) Hecho en, 18) Fecha, 19) Nombre del signatario, 20) Función, 21) Firma.

et : 1) EÜ vastavusdeklaratsioon (algupärane), 2) Äriühing, 3) Aadress, 4) Tehniline dokumentatsioon, 5) Seadme tootja, 6) Kinnitab, et see toode, 7) On vastavuses järgmistele direktiivide ja nende riigisisese õiguse ülevõtmiseks vastuvõetud õigusaktidega, 8) IV lisas loetletud seadmete puhul, 9) Tunnistuse number, 10) Serifitseerimisasutus, 15) kasutatud ühtlustatud standardite, 16) Muud standardites või spetsifikatsioonides kasutatakse, 17) Väljaandmise koht, 18) Väljaandmise aeg, 19) Allkirjastaja nimi, 20) Amet, 21) Allkiri.

fi : 1) EY-vaatimustenmukaisuusvakuutus (alkuperäiset), 2) Yritys, 3) Osoite, 4) teknisen eritelmän, 5) Jäljessä kuvattu koneen valmistaja, 6) Vakuuttaa, että tämä kone, 7) Täyttää seuraavien direktiivien sekä niitä vastaavien kansallisten säännösten vaatimukset, 8) Liitteen IV koneiden osalta, 9) Todistuksen numero, 10) Ilmoitettu laitos, 15) yhdenmukaistettuja standardeja käytetään, 16) muita standardeja tai eritelmiä, 17) Paikka, 18) Aika, 19) Allekirjoittajan nimi, 20) Toimi, 21) Allekirjoitus.

ga : 1) « EC » dearbhú comhréireachta (bunaidh), 2) An comhlacht, 3) Seoladh, 4) comhad teicniúil, 5) Déantóir an innill a thuairiscítear thíos, 6) Dearbhaíonn sé go bhfuil an t-inneall, 7) Go gcoinn sé le na teoracha seo a leanas agus a trasúimh isteach i ndlí náisiúnta, 8) Le haghaidh innill an aguisín IV, 9) Uimhir teastais, 10) Comhlacht a chuireadh i bhfios, 15) caighdeán comhchuibhithe a úsáidtear, 16) caighdeán eile nó sonraíochtaí teicniúla a úsáidtear, 17) Déanta ag, 18) Dáta, 19) Ainm an tsíniheora, 20) Feidhm, 21) Síniú.

hu : 1) CE megfelelő ségi nyilatkozat (eredeti), 2) A vállalat, 3) Cím, 4) műszaki dokumentáció, 5) Az alábbi gép gyártója, 6) Kijelenti, hogy a gép, 7) Megfelel az alábbi irányelveknek valamint azok honosított előírásainak, 8) A IV. melléklet gépeihez, 9) Bizonylati szám, 10) Értesített szervezet, 15) felhasznált harmonizált szabványok, 16) egyéb felhasznált műszaki előírások hivatkozásai, 17) Kelt (hely), 18) Dátum, 19) Aláíró neve, 20) Funkció, 21) Aláírás.

is : 1) Samræmisvottorð ESB (upprunalega), 2) Fyrirtækið, 3) Aðsetur, 4) Tæknilegar skrá, 5) Smíður tækisins sem lýst er hér á eftir, 6) Staðfestir að tækið, 7) Samræmist eftirfarandi stöðlum og staðfærslu þeirra með hliðsjón af þjóðarrétti, 8) Fyrir tækin í aukakalla IV, 9) Staðfestingarnúmer, 10) Tilkynnt til, 15) samhæða staðla sem notaðir, 16) önnur staðlar eða forskrifir notað, 17) Staður, 18) Dagsetning, 19) Nafn undirritaðs, 20) Staða, 21) Undirskrift.

it : 1) Dichiarazione CE di conformità (originale), 2) La società, 3) Indirizzo, 4) fascicolo tecnico, 5) Costruttore della macchina descritta di seguito, 6) Dichiaro che questa macchina, 7) È conforme alle direttive seguenti e alle relative trasposizioni nel diritto nazionale, 8) Per le macchine Allegato IV, 9) Numero di Attestazione, 10) Organismo notificato, 15) norme armonizzate applicate, 16) altre norme e specifiche tecniche applicate, 17) Stabilità a, 18) Data, 19) Nome del firmatario, 20) Funzione, 21) Firma.

lt : 1) CE atitikties deklaracija (originalas), 2) Bendrovė, 3) Adresas, 4) Techninė byla, 5) Žemiau nurodytas įrenginio gamintojas, 6) Pareiškia, kad šis įrenginys, 7) Atitinka toliau nurodytas direktyvas ir j nacionalinius teisės aktus perkeltas jų nuostatas, 8) IV priedas dėl mašinų, 9) Serifikato Nr., 10) Paskelbtoji įstaiga, 15) suderintus standartus naudojamus, 16) Kiti standartai ir techninės specifikacijos, 17) Pasirašyta, 18) Data, 19) Pasirašiusio asmens vardas ir pavardė, 20) Pareigos, 21) Parašas.

lv : 1) EK atbilstības deklarācija (oriģināls), 2) Uzņēmums, 3) Adrese, 4) tehniskās lietas, 5) Tālāk aprakstītās iekārtas ražotājs, 6) Apliecinā, ka šī iekārta, 7) Ir atbilstoša tālāk norādītajām direktīvām un to transponētajām nacionālajām likumdošanā, 8) Iekārtām IV pielikumā, 9) Apliecināšanas numurs, 10) Reģistrētā organizācija, 15) lietotajiem saskaņotajiem standartiem, 16) lietotajiem tehniskajiem standartiem un specifikācijām, 17) Sastādīts, 18) Datums, 19) Parakstītāja vārds, 20) Amats, 21) Paraksts.

mt : 1) Dikjarazzjoni ta' Konformità KE (originali), 2) Il-kumpanija, 3) Indirizz, 4) fajl tekniku, 5) Manifattriċi tal-magna deskritta hawn isfel, 6) Tiddikjara li din il-magna, 7) Hija konformi hija konformi mad-Direttivi segwenti u l-ligijiet li jimplimentawhom fil-ligijiet nazzjonali, 8) Għall-magni fl-Anness IV, 9) Numru taċ-ċertifikat, 10) Entità nnotifikata, 15) l-istandards armonizzati użati, 16) standards tekniċi u speċifikazzjonijiet oħra użati, 17) Magħmul f', 18) Data, 19) lsem il-firmatarju, 20) Kariga, 21) Firma.

nl : 1) EG-verklaring van overeenstemming (oorspronkelijke), 2) Het bedrijf, 3) Adres, 4) technisch dossier, 5) Constructeur van de hierna genoemde machine, 6) Verklaart dat deze machine, 7) In overeenstemming is met de volgende richtlijnen en hun omzettingen in het nationale recht, 8) Voor machines van bijlage IV, 9) Goedkeuringsnummer, 10) Aangezegde instelling, 15) gehanteerde geharmoniseerde normen, 16) andere gehanteerde technische normen en specificaties, 17) Opgemaakt te, 18) Datum, 19) Naam van ondergetekende, 20) Functie, 21) Handtekening.

no : 1) CE-samsvarserklæring (original), 2) Selskapet, 3) Adresse, 4) tekniske arkiv, 5) Fabrikant av følgende maskin, 6) Erklærer at denne maskinen, 7) Oppfyller kravene i følgende direktiver, med nasjonale gjennomføringsbestemmelser, 8) For maskinene i tillegg IV, 9) Attestnummer, 10) Notifisert organ, 15) harmoniserte standarder som brukes, 16) Andre standarder og spesifikasjoner brukt, 17) Utstedt i, 18) Dato, 19) Underskrivers navn, 20) Stilling, 21) Underskrift.

pl : 1) Deklaracja zgodności CE (oryginalne), 2) Spółka, 3) Adres, 4) dokumentacji technicznej, 5) Wykonawca maszyny opisanej poniżej, 6) Oświadczka, że ta maszyna, 7) Jest zgodna z następującymi dyrektywami i odpowiadającymi przepisami prawa krajowego, 8) Dla maszyn załącznik IV, 9) Numer certyfikatu, 10) Jednostka certyfikująca, 15) zastosowanych norm zharmonizowanych, 16) innych zastosowanych norm technicznych i specyfikacji, 17) Sporządzono w, 18) Data, 19) Nazwisko podpisującego, 20) Stanowisko, 21) Podpis.

pt : 1) Declaração de conformidade CE (original), 2) A empresa, 3) Morada, 4) processo técnico, 5) Fabricante da máquina descrita abaixo, 6) Declara que esta máquina, 7) Está em conformidade às directivas seguintes e às suas transposições para o direito nacional, 8) Para as máquinas no anexo IV, 9) Número de certificado, 10) Entidade notificada, 15) normas harmonizadas utilizadas, 16) outras normas e especificações técnicas utilizadas, 17) Elaborado em, 18) Data, 19) Nome do signatário, 20) Cargo, 21) Assinatura.

ro : 1) Declarație de conformitate CE (originală), 2) Societatea, 3) Adresa, 4) cărțile tehnice, 5) Constructor al mașinii descrise mai jos, 6) Declară că prezenta mașină, 7) Este conformă cu directivele următoare și cu transpunerea lor în dreptul național, 8) Pentru mașinile din anexa IV, 9) Număr de atestare, 10) Organism notificat, 15) standardele armonizate utilizate, 16) alte standarde și specificații tehnice utilizate, 17) Întocmit la, 18) Data, 19) Numele persoanei care semnează, 20) Funcția, 21) Semnătură.

sk : 1) ES vyhlásenie o zhode (pôvodný), 2) Názov spoločnosti, 3) Adresa, 4) technickej dokumentácie, 5) Výrobca nižšie opísaného stroja, 6) Vyhlasuje, že tento stroj, 7) Je v súlade s nasledujúcimi smernicami a smernicami transponovanými do vnútroštátneho práva, 8) Pre stroje v prílohe IV, 9) Číslo certifikátu, 10) Notifikačný orgán, 15) použité harmonizované normy, 16) použité iné technické normy a predpisy, 17) Miesto vydania, 18) Dátum vydania, 19) Meno podpisujúceho, 20) Funkcia, 21) Podpis.

sl : 1) ES Izjava o ustreznosti (izvirna), 2) Družba, 3) Naslov, 4) tehnične dokumentacije, 5) Proizvajalac tukaj opisanega stroja, 6) Izjavlja, da je ta stroj, 7) Ustreza naslednjim direktivam in njihovi transpoziciji v državno pravo, 8) Za stroje priloga IV, 9) Številka potrdila, 10) Obvestilo organu, 15) uporabljene harmonizirane standarde, 16) druge uporabljene tehnične standarde in zahteve, 17) V, 18) Datum, 19) Ime podpisnika, 20) Funkcija, 21) Podpis.

sv : 1) CE-försäkran om överensstämmelse (original), 2) Företaget, 3) Adress, 4) tekniska dokumentationen, 5) Konstruktör av nedan beskrivna maskin, 6) Försäkrar att denna maskin, 7) Överensstämmer med nedanstående direktiv och införlivandet av dem i nationell rätt, 8) För maskinerna i bilaga IV, 9) Nummer för godkännande, 10) Organism som underrättats, 15) Harmoniserade standarder som använts, 16) andra tekniska standarder och specifikationer som använts, 17) Upprättat i, 18) Datum, 19) Namn på den som undertecknat, 20) Befattning, 21) Namnteckning.

IDENTIFICATION OF THE LIFT TRUCK

As our policy is to promote a constant improvement of our products, our range of telescopic lift trucks may undergo certain modifications, without obligation for us to advise our customers.

When you order parts, or when you require any technical information, always specify:

NOTE: For the owner's convenience, it is recommended that a note of these numbers is made in the spaces provided, at the time of the delivery of the lift truck.

LIFT TRUCK MANUFACTURER'S PLATE (FIG. A)

- Model
- Series
- Serial Nr
- Year of manufacture

For any further technical information regarding your lift truck refer to chapter: 2 - DESCRIPTION: CHARACTERISTICS.

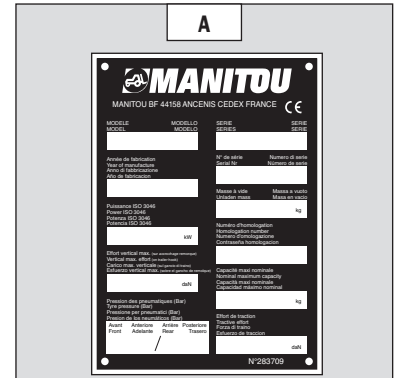

I.C. ENGINE (FIG. B)

- Model
- Serial Nr
- I.C. engine Nr

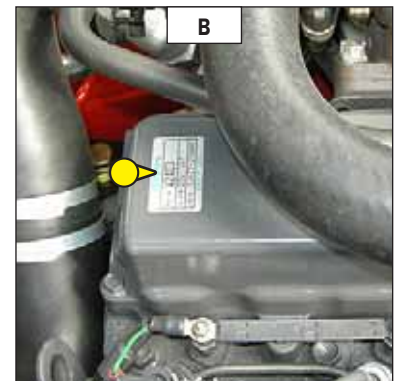

HYDROSTATIC PUMP (FIG. C)

- MANITOU reference
- Type of codification
- Serial Nr
- Manufacturer's Nr
- Year of manufacture

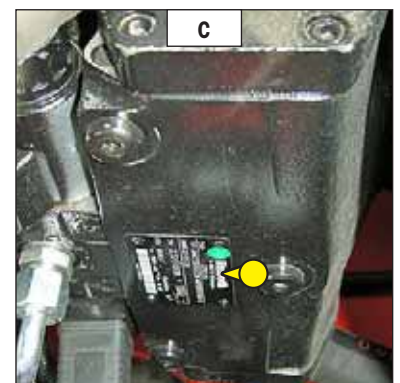

FRONT WHEEL HYDROSTATIC MOTORS (FIG. D)

- MANITOU reference
- Type of codification
- Serial Nr
- Manufacturer's Nr
- Year of manufacture

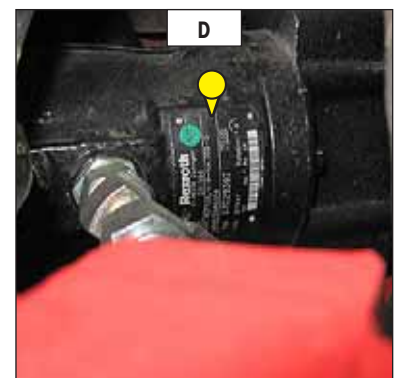

FRONT WHEEL REDUCERS (FIG. E)

- Type
- Serial Nr
- Date

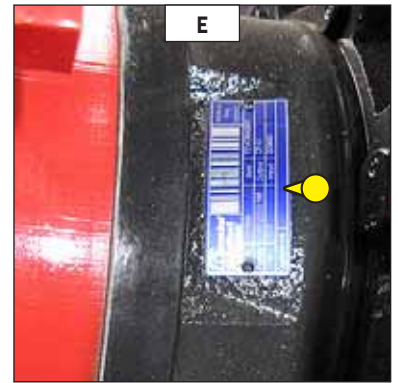

REAR WHEEL HYDROSTATIC MOTORS (FIG. F)

MH 20-4 T BUGGIE Série 2-E3
 MH 25-4 T BUGGIE Série 2-E3

- Type of codification
- Motor Nr
- Manufacturer's Nr
- Year of manufacture

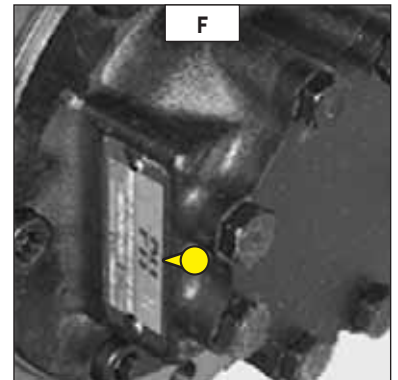

OVERHEAD GUARD (FIG. G)

- Type
- Serial Nr

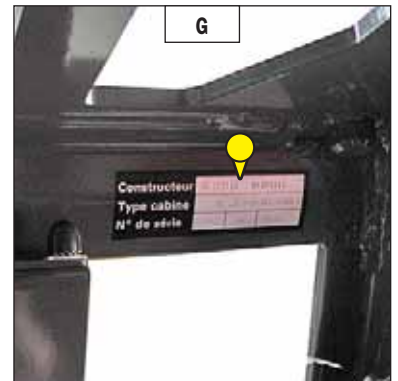

CAB (FIG. H)

- Model
- Serial Nr
- Year of manufacture

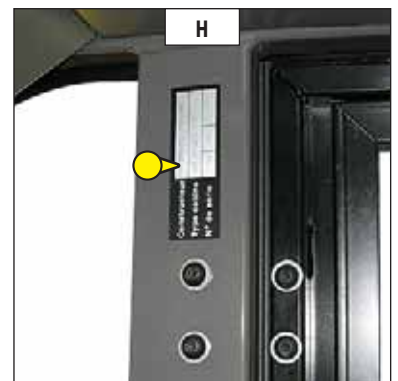

MAST (FIG. I)

- Mast identification Nr



ATTACHMENT MANUFACTURER'S PLATE (FIG. J)

- Model
- Serial Nr
- Year of manufacture

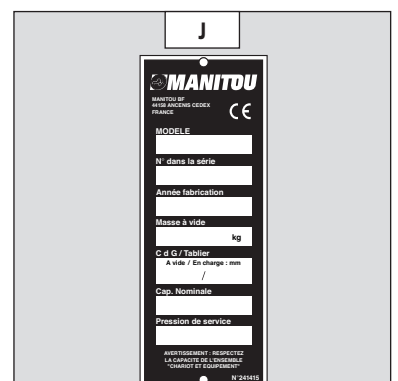

CHARACTERISTICS

MSI 20 T Série 2-E3

MSI 20 T BUGGIE Série 2-E3

I.C. ENGINE		
Type		KUBOTA V2403 M T E3 1J477-23000
Fuel		Diesel
Number of cylinders		4 in line
Suction		Supercharged
Injection system		Mechanical
Ignition sequence		1-3-4-2
Capacity	cm3	2434
Bore and stroke	mm	87 x 102,4
Compression ratio		23/1
Nominal rating loaded	rpm	2700
Rating slow unladen	rpm	900
Max. rating unladen	rpm	2920
Power ISO/TR 14396	cv- kW	60 - 44
Power SAE J 1995	cv- kW	60 - 44
Maximum torque ISO/TR 14396	Nm	165 to 1600 rpm
Air cleaner	µm	3
Type of cooling		By water
Fan		Blowing

TRANSMISSION		
Hydrostatic pump		REXROTH
Type		A4VG71DA1D7/32R with variable cubic capacity and with automatic power governor
Forward/reverse selector		Electro-hydraulic
Number of forward speeds		1
Number of reverse speeds		1
Main pump		
MAX./MIN. displacement	cm3/r	0 - 71
MAX. flow rate	l/mn	210
Working pressure	bar	500
Boost pump		
Capacity	cm3/r	19,6
MAX. flow rate	l/mn	58
Boost pressure MAX. R.P.M.	bar	30
Front wheel hydrostatic motor		REXROTH
Type		A2FE28/61W with fixed capacity
MAX. displacement	cm3/r	28
Front wheel reducer		BREVINI
Drive wheels		2 RM Permanent
Switch for 2/4 drive wheels		No
Front tyres		GOODYEAR
Size		275/70 R22,5 148/145M Regional RHS
Pressure	bar	9
Rear tyres		CONTINENTAL
Size		7.00X12 14PR IC40
Pressure	bar	4,5

ELECTRIC CIRCUIT		
Battery	Standard Option	12 V - 110 Ah - 750 A EN
Alternator		12 V - 70 A
Type		Denso 19279-64010
Starter		12 V - 2 kW
Type		17123-63010

BRAKE CIRCUIT		
Service brake		Low pressure hydraulic brake
Type of brake		Multidisc brake immersed in oil
Type of control		By foot on front wheels
Parking brake		Low pressure hydraulic brake
Type of brake		Multidisc brake immersed in oil
Type of control		Switch-operated electro-hydraulic

HYDRAULIC CIRCUIT		
Hydraulic pump		CASAPPA
Type		Gear pump
Capacity	cm ³	26
Max. rating capacity unladen	l/mn	77
Flow rate at 1800 rpm	l/mn	48
Filtration		
Return	µm	10
Suction	µm	100
Maximum service pressure		
Double mast with all-round vision	bar	140
Triple mast with free-acting lift	bar	140
Double mast with free-acting lift	bar	140
Triple mast without free-acting lift	bar	145
Front/rear tilting circuit	bar	140/140
Attachment circuit	bar	140
Steering circuit	bar	125

HYDRAULIC MOVEMENTS		
Lifting movements		
Unladen lifting	m/s	0,5
Laden lifting	m/s	0,4
Unladen lowering	m/s	0,5
Laden lowering	m/s	0,6

SOUND AND VIBRATION		
Level of sound pressure in the driver's cab LpA (according to standard NF EN 12053)	dB	82
Level of sound power ensured in the LWA environment (according to directive 2000/14/EC modified by directive 2005/88/EC)	dB	measured/guaranteed
Average weighted acceleration on driver's body (according to standard NF EN 13059)	m/s ²	
The average weighted acceleration transmitted to the driver's hand/arm system (according to standard ISO 5349-2)	m/s ²	<2,5

SPECIFICATIONS AND WEIGHTS		
Speed of movement for lift truck in standard configuration on flat ground (except particular conditions)		
Front unladen	km/h	20
Rear unladen	km/h	20
Standard mast		DVT 3M30
Lift height	mm	3300
Free lift height	mm	130
Overall height (retracted)	mm	2300
Overall height (extended)	mm	4131
Carriage		
Class		FEM2A
width	mm	1260
Weight of forks (each)	kg	43
Rated load capacity	kg	2000
Rated load capacity with standard mast	kg	2000
Effective load capacity on forks with side-shift carriage	kg	2000
Distance from the centre of gravity of the load to the base of the forks	mm	500
Lift truck weight without forks or mast	kg	3049
Lift truck weight with standard mast		
Unladen	kg	3770
At rated load	kg	5770
Axle weight with standard mast (transport position)		
Front unladen	kg	1661
Rear unladen	kg	2109
Front rated load	kg	4911
Rear rated load	kg	859
Drag strain on the coupling hook		
Unladen (sliding)	daN	1370
At rated load (transmission setting)	daN	2280
Pull strain with open carrier (according to standard ISO 8313)	daN	

CHARACTERISTICS

MSI 25 T Série 2-E3

MSI 25 T BUGGIE Série 2-E3

I.C. ENGINE		
Type		KUBOTA V2403 M T E3 1J477-23000
Fuel		Diesel
Number of cylinders		4 in line
Suction		Supercharged
Injection system		Mechanical
Ignition sequence		1-3-4-2
Capacity	cm3	2434
Bore and stroke	mm	87 x 102,4
Compression ratio		23/1
Nominal rating loaded	rpm	2700
Rating slow unladen	rpm	900
Max. rating unladen	rpm	2920
Power ISO/TR 14396	cv- kW	60 - 44
Power SAE J 1995	cv- kW	60 - 44
Maximum torque ISO/TR 14396	Nm	165 to 1600 rpm
Air cleaner	µm	3
Type of cooling		By water
Fan		Blowing

TRANSMISSION		
Hydrostatic pump		REXROTH
Type		A4VG71DA1D7/32R with variable cubic capacity and with automatic power governor
Forward/reverse selector		Electro-hydraulic
Number of forward speeds		1
Number of reverse speeds		1
Main pump		
MAX./MIN. displacement	cm3/r	0 - 71
MAX. flow rate	l/mn	210
Working pressure	bar	500
Boost pump		
Capacity	cm3/r	19,6
MAX. flow rate	l/mn	58
Boost pressure MAX. R.P.M.	bar	30
Front wheel hydrostatic motor		REXROTH
Type		A2FE28/61W with fixed capacity
MAX. displacement	cm3/r	28
Front wheel reducer		BREVINI
Drive wheels		2 RM Permanent
Switch for 2/4 drive wheels		No
Front tyres		GOODYEAR
Size		275/70 R22,5 148/145M Regional RHS
Pressure	bar	9
Rear tyres		CONTINENTAL
Size		7.00X12 14PR IC40
Pressure	bar	5,3

ELECTRIC CIRCUIT		
Battery	Standard Option	12 V - 110 Ah - 750 A EN
Alternator		12 V - 70 A
Type		Denso 19279-64010
Starter		12 V - 2 kW
Type		17123-63010

BRAKE CIRCUIT		
Service brake		Low pressure hydraulic brake
Type of brake		Multidisc brake immersed in oil
Type of control		By foot on front wheels
Parking brake		Low pressure hydraulic brake
Type of brake		Multidisc brake immersed in oil
Type of control		Switch-operated electro-hydraulic

HYDRAULIC CIRCUIT		
Hydraulic pump		CASAPPA
Type		Gear pump
Capacity	cm ³	26
Max. rating capacity unladen	l/mn	77
Flow rate at 1800 rpm	l/mn	48
Filtration		
Return	µm	10
Suction	µm	100
Maximum service pressure		
Double mast with all-round vision	bar	170
Triple mast with free-acting lift	bar	170
Double mast with free-acting lift	bar	170
Triple mast without free-acting lift	bar	180
Front/rear tilting circuit	bar	170/170
Attachment circuit	bar	170
Steering circuit	bar	125

HYDRAULIC MOVEMENTS		
Lifting movements		
Unladen lifting	m/s	0,5
Laden lifting	m/s	0,4
Unladen lowering	m/s	0,5
Laden lowering	m/s	0,6

SOUND AND VIBRATION		
Level of sound pressure in the driver's cab LpA (according to standard NF EN 12053)	dB	82
Level of sound power ensured in the LWA environment (according to directive 2000/14/EC modified by directive 2005/88/EC)	dB	measured/guaranteed
Average weighted acceleration on driver's body (according to standard NF EN 13059)	m/s ²	
The average weighted acceleration transmitted to the driver's hand/arm system (according to standard ISO 5349-2)	m/s ²	<2,5

SPECIFICATIONS AND WEIGHTS		
Speed of movement for lift truck in standard configuration on flat ground (except particular conditions)		
Front unladen	km/h	20
Rear unladen	km/h	20
Standard mast		DVT 3M30
Lift height	mm	3300
Free lift height	mm	130
Overall height (retracted)	mm	2300
Overall height (extended)	mm	4131
Carriage		
Class		FEM2A
width	mm	1260
Weight of forks (each)	kg	43
Rated load capacity	kg	2500
Rated load capacity with standard mast	kg	2500
Effective load capacity on forks with side-shift carriage	kg	2500
Distance from the centre of gravity of the load to the base of the forks	mm	500
Lift truck weight without forks or mast	kg	3349
Lift truck weight with standard mast		
Unladen	kg	4070
At rated load	kg	6650
Axle weight with standard mast (transport position)		
Front unladen	kg	1632
Rear unladen	kg	2437
Front rated load	kg	5695
Rear rated load	kg	874
Drag strain on the coupling hook		
Unladen (sliding)	daN	1370
At rated load (transmission setting)	daN	2280
Pull strain with open carrier (according to standard ISO 8313)	daN	

CHARACTERISTICS

MSI 30 T Série 2-E3

MSI 30 T BUGGIE Série 2-E3

I.C. ENGINE		
Type		KUBOTA V2403 M T E3 1J477-23000
Fuel		Diesel
Number of cylinders		4 in line
Suction		Supercharged
Injection system		Mechanical
Ignition sequence		1-3-4-2
Capacity	cm3	2434
Bore and stroke	mm	87 x 102,4
Compression ratio		23/1
Nominal rating loaded	rpm	2700
Rating slow unladen	rpm	900
Max. rating unladen	rpm	2920
Power ISO/TR 14396	cv- kW	60 - 44
Power SAE J 1995	cv- kW	60 - 44
Maximum torque ISO/TR 14396	Nm	165 to 1600 rpm
Air cleaner	µm	3
Type of cooling		By water
Fan		Blowing

TRANSMISSION		
Hydrostatic pump		REXROTH
Type		A4VG71DA1D7/32R with variable cubic capacity and with automatic power governor
Forward/reverse selector		Electro-hydraulic
Number of forward speeds		1
Number of reverse speeds		1
Main pump		
MAX./MIN. displacement	cm3/r	0 - 71
MAX. flow rate	l/mn	210
Working pressure	bar	500
Boost pump		
Capacity	cm3/r	19,6
MAX. flow rate	l/mn	58
Boost pressure MAX. R.P.M.	bar	30
Front wheel hydrostatic motor		REXROTH
Type		A2FE28/61W with fixed capacity
MAX. displacement	cm3/r	28
Front wheel reducer		BREVINI
Drive wheels		2 RM Permanent
Switch for 2/4 drive wheels		No
Front tyres		GOODYEAR
Size		275/70 R22,5 148/145M Regional RHS
Pressure	bar	9
Rear tyres		CONTINENTAL
Size		7.00X12 14PR IC40
Pressure	bar	5,3

ELECTRIC CIRCUIT		
Battery	Standard Option	12 V - 110 Ah - 750 A EN
Alternator		12 V - 70 A
Type		Denso 19279-64010
Starter		12 V - 2 kW
Type		17123-63010

BRAKE CIRCUIT		
Service brake		Low pressure hydraulic brake
Type of brake		Multidisc brake immersed in oil
Type of control		By foot on front wheels
Parking brake		Low pressure hydraulic brake
Type of brake		Multidisc brake immersed in oil
Type of control		Switch-operated electro-hydraulic

HYDRAULIC CIRCUIT		
Hydraulic pump		CASAPPA
Type		Gear pump
Capacity	cm ³	26
Max. rating capacity unladen	l/mn	77
Flow rate at 1800 rpm	l/mn	48
Filtration		
Return	µm	10
Suction	µm	100
Maximum service pressure		
Double mast with all-round vision	bar	185
Triple mast with free-acting lift	bar	185
Double mast with free-acting lift	bar	185
Triple mast without free-acting lift	bar	
Front/rear tilting circuit	bar	185/185
Attachment circuit	bar	185
Steering circuit	bar	125

HYDRAULIC MOVEMENTS		
Lifting movements		
Unladen lifting	m/s	0,5
Laden lifting	m/s	0,4
Unladen lowering	m/s	0,4
Laden lowering	m/s	0,5

SOUND AND VIBRATION		
Level of sound pressure in the driver's cab LpA (according to standard NF EN 12053)	dB	82
Level of sound power ensured in the LWA environment (according to directive 2000/14/EC modified by directive 2005/88/EC)	dB	measured/guaranteed
Average weighted acceleration on driver's body (according to standard NF EN 13059)	m/s ²	
The average weighted acceleration transmitted to the driver's hand/arm system (according to standard ISO 5349-2)	m/s ²	<2,5

SPECIFICATIONS AND WEIGHTS		
Speed of movement for lift truck in standard configuration on flat ground (except particular conditions)		
Front unladen	km/h	20
Rear unladen	km/h	20
Standard mast		DVT 3M30
Lift height	mm	3300
Free lift height	mm	130
Overall height (retracted)	mm	2300
Overall height (extended)	mm	4193
Carriage		
Class		FEM2A
width	mm	1260
Weight of forks (each)	kg	55
Rated load capacity	kg	3000
Rated load capacity with standard mast	kg	3000
Effective load capacity on forks with side-shift carriage	kg	3000
Distance from the centre of gravity of the load to the base of the forks	mm	500
Lift truck weight without forks or mast	kg	3959
Lift truck weight with standard mast		
Unladen	kg	4704
At rated load	kg	7704
Axle weight with standard mast (transport position)		
Front unladen	kg	1899
Rear unladen	kg	2805
Front rated load	kg	6782
Rear rated load	kg	922
Drag strain on the coupling hook		
Unladen (sliding)	daN	1260
At rated load (transmission setting)	daN	2460
Pull strain with open carrier (according to standard ISO 8313)	daN	

CHARACTERISTICS

MSI 35 T Série 2-E3

MSI 35 T BUGGIE Série 2-E3

I.C. ENGINE		
Type		KUBOTA V2403 M T E3 1J477-23000
Fuel		Diesel
Number of cylinders		4 in line
Suction		Supercharged
Injection system		Mechanical
Ignition sequence		1-3-4-2
Capacity	cm3	2434
Bore and stroke	mm	87 x 102,4
Compression ratio		23/1
Nominal rating loaded	rpm	2700
Rating slow unladen	rpm	900
Max. rating unladen	rpm	2920
Power ISO/TR 14396	cv- kW	60 - 44
Power SAE J 1995	cv- kW	60 - 44
Maximum torque ISO/TR 14396	Nm	165 to 1600 rpm
Air cleaner	µm	3
Type of cooling		By water
Fan		Blowing

TRANSMISSION		
Hydrostatic pump		REXROTH
Type		A4VG71DA1D7/32R with variable cubic capacity and with automatic power governor
Forward/reverse selector		Electro-hydraulic
Number of forward speeds		1
Number of reverse speeds		1
Main pump		
MAX./MIN. displacement	cm3/r	0 - 71
MAX. flow rate	l/mn	210
Working pressure	bar	500
Boost pump		
Capacity	cm3/r	19,6
MAX. flow rate	l/mn	58
Boost pressure MAX. R.P.M.	bar	30
Front wheel hydrostatic motor		REXROTH
Type		A2FE28/61W with fixed capacity
MAX. displacement	cm3/r	28
Front wheel reducer		BREVINI
Drive wheels		2 RM Permanent
Switch for 2/4 drive wheels		No
Front tyres		GOODYEAR
Size		275/70 R22,5 148/145M Regional RHS
Pressure	bar	9
Rear tyres		CONTINENTAL
Size		7.00X12 14PR IC40
Pressure	bar	7,5

ELECTRIC CIRCUIT		
Battery	Standard Option	12 V - 110 Ah - 750 A EN
Alternator		12 V - 70 A
Type		Denso 19279-64010
Starter		12 V - 2 kW
Type		17123-63010

BRAKE CIRCUIT		
Service brake		Low pressure hydraulic brake
Type of brake		Multidisc brake immersed in oil
Type of control		By foot on front wheels
Parking brake		Low pressure hydraulic brake
Type of brake		Multidisc brake immersed in oil
Type of control		Switch-operated electro-hydraulic

HYDRAULIC CIRCUIT		
Hydraulic pump		CASAPPA
Type		Gear pump
Capacity	cm ³	26
Max. rating capacity unladen	l/mn	77
Flow rate at 1800 rpm	l/mn	48
Filtration		
Return	µm	10
Suction	µm	100
Maximum service pressure		
Double mast with all-round vision	bar	190
Triple mast with free-acting lift	bar	220
Double mast with free-acting lift	bar	190
Triple mast without free-acting lift	bar	
Front/rear tilting circuit	bar	190/190
Attachment circuit	bar	190
Steering circuit	bar	125

HYDRAULIC MOVEMENTS		
Lifting movements		
Unladen lifting	m/s	0,5
Laden lifting	m/s	0,4
Unladen lowering	m/s	0,3
Laden lowering	m/s	0,4

SOUND AND VIBRATION		
Level of sound pressure in the driver's cab LpA (according to standard NF EN 12053)	dB	82
Level of sound power ensured in the LWA environment (according to directive 2000/14/EC modified by directive 2005/88/EC)	dB	measured/guaranteed
Average weighted acceleration on driver's body (according to standard NF EN 13059)	m/s ²	
The average weighted acceleration transmitted to the driver's hand/arm system (according to standard ISO 5349-2)	m/s ²	<2,5

SPECIFICATIONS AND WEIGHTS		
Speed of movement for lift truck in standard configuration on flat ground (except particular conditions)		
Front unladen	km/h	20
Rear unladen	km/h	20
Standard mast		DVT 3M30
Lift height	mm	3300
Free lift height	mm	135
Overall height (retracted)	mm	2300
Overall height (extended)	mm	4193
Carriage		
Class		FEM3A
width	mm	1260
Weight of forks (each)	kg	68
Rated load capacity	kg	3500
Rated load capacity with standard mast	kg	3500
Effective load capacity on forks with side-shift carriage	kg	3200
Distance from the centre of gravity of the load to the base of the forks	mm	500
Lift truck weight without forks or mast	kg	4054
Lift truck weight with standard mast		
Unladen	kg	4845
At rated load	kg	8345
Axle weight with standard mast (transport position)		
Front unladen	kg	1732
Rear unladen	kg	3113
Front rated load	kg	7430
Rear rated load	kg	915
Drag strain on the coupling hook		
Unladen (sliding)	daN	1560
At rated load (transmission setting)	daN	2640
Pull strain with open carrier (according to standard ISO 8313)		
	daN	

CHARACTERISTICS

MH 20-4 T BUGGIE Série 2-E3

I.C. ENGINE		
Type		KUBOTA V2403 M T E3 1J477-23000
Fuel		Diesel
Number of cylinders		4 in line
Suction		Supercharged
Injection system		Mechanical
Ignition sequence		1-3-4-2
Capacity	cm3	2434
Bore and stroke	mm	87 x 102,4
Compression ratio		23/1
Nominal rating loaded	rpm	2700
Rating slow unladen	rpm	900
Max. rating unladen	rpm	2920
Power ISO/TR 14396	cv- kW	60 - 44
Power SAE J 1995	cv- kW	60 - 44
Maximum torque ISO/TR 14396	Nm	165 to 1600 rpm
Air cleaner	µm	3
Type of cooling		By water
Fan		Blowing

TRANSMISSION		
Hydrostatic pump		REXROTH
Type		A4VG71DA1D7/32R with variable cubic capacity and with automatic power governor
Forward/reverse selector		Electro-hydraulic
Number of forward speeds		1
Number of reverse speeds		1
Main pump		
MAX./MIN. displacement	cm3/r	0 - 71
MAX. flow rate	l/mn	210
Working pressure	bar	500
Boost pump		
Capacity	cm3/r	19,6
MAX. flow rate	l/mn	58
Boost pressure MAX. R.P.M.	bar	30
Front wheel hydrostatic motor		REXROTH
Type		A2FE28/61W with fixed capacity
MAX. displacement	cm3/r	28
Front wheel reducer		BREVINI
Rear wheel hydrostatic motor		POCLAIN
Type		MS02 with fixed capacity
MAX. displacement	cm3/r	398
Drive wheels		4 RM Permanent
Switch for 2/4 drive wheels		No
Front tyres		MICHELIN
Size		280/80 R20 133A8 XMCL
Pressure	bar	4,1
Rear tyres		CONTINENTAL
Size		27.10-12 14PR IC30
Pressure	bar	7

ELECTRIC CIRCUIT		
Battery	Standard Option	12 V - 110 Ah - 750 A EN
Alternator		12 V - 70 A
Type		Denso 19279-64010
Starter		12 V - 2 kW
Type		17123-63010

BRAKE CIRCUIT	
Service brake	Low pressure hydraulic brake
Type of brake	Multidisc brake immersed in oil
Type of control	By foot on front wheels
Parking brake	Low pressure hydraulic brake
Type of brake	Multidisc brake immersed in oil
Type of control	Switch-operated electro-hydraulic

HYDRAULIC CIRCUIT		
Hydraulic pump		CASAPPA
Type		Gear pump
Capacity	cm ³	26
Max. rating capacity unladen	l/mn	77
Flow rate at 1800 rpm	l/mn	48
Filtration		
Return	µm	10
Suction	µm	100
Maximum service pressure		
Double mast with all-round vision	bar	140
Triple mast with free-acting lift	bar	145
Double mast with free-acting lift	bar	
Triple mast without free-acting lift	bar	150
Front/rear tilting circuit	bar	150/150
Attachment circuit	bar	150
Steering circuit	bar	125

HYDRAULIC MOVEMENTS		
Lifting movements		
Unladen lifting	m/s	0,6
Laden lifting	m/s	0,4
Unladen lowering	m/s	0,5
Laden lowering	m/s	0,6

SOUND AND VIBRATION		
Level of sound pressure in the driver's cab LpA (according to standard NF EN 12053)	dB	82
Level of sound power ensured in the LWA environment (according to directive 2000/14/EC modified by directive 2005/88/EC)	dB	measured/guaranteed
Average weighted acceleration on driver's body (according to standard NF EN 13059)	m/s ²	
The average weighted acceleration transmitted to the driver's hand/arm system (according to standard ISO 5349-2)	m/s ²	<2,5

SPECIFICATIONS AND WEIGHTS		
Speed of movement for lift truck in standard configuration on flat ground (except particular conditions)		
Front unladen	km/h	14
Rear unladen	km/h	14
Standard mast		TSL 3M30
Lift height	mm	3300
Free lift height	mm	0
Overall height (retracted)	mm	1835
Overall height (extended)	mm	4070
Carriage		
Class		FEM2A
width	mm	1260
Weight of forks (each)		43
Rated load capacity		2000
Rated load capacity with standard mast		2000
Effective load capacity on forks with side-shift carriage		2000
Distance from the centre of gravity of the load to the base of the forks		500
Lift truck weight without forks or mast		3209
Lift truck weight with standard mast		
Unladen	kg	3955
At rated load	kg	5955
Axle weight with standard mast (transport position)		
Front unladen	kg	1841
Rear unladen	kg	2114
Front rated load	kg	5091
Rear rated load	kg	864
Drag strain on the coupling hook		
Unladen (sliding)	daN	2190
At rated load (transmission setting)	daN	3550
Pull strain with open carrier (according to standard ISO 8313)		daN

CHARACTERISTICS

MH 25-4 T BUGGIE Série 2-E3

I.C. ENGINE		
Type		KUBOTA V2403 M T E3 1J477-23000
Fuel		Diesel
Number of cylinders		4 in line
Suction		Supercharged
Injection system		Mechanical
Ignition sequence		1-3-4-2
Capacity	cm3	2434
Bore and stroke	mm	87 x 102,4
Compression ratio		23/1
Nominal rating loaded	rpm	2700
Rating slow unladen	rpm	900
Max. rating unladen	rpm	2920
Power ISO/TR 14396	cv- kW	60 - 44
Power SAE J 1995	cv- kW	60 - 44
Maximum torque ISO/TR 14396	Nm	165 to 1600 rpm
Air cleaner	µm	3
Type of cooling		By water
Fan		Blowing

TRANSMISSION		
Hydrostatic pump		REXROTH
Type		A4VG71DA1D7/32R with variable cubic capacity and with automatic power governor
Forward/reverse selector		Electro-hydraulic
Number of forward speeds		1
Number of reverse speeds		1
Main pump		
MAX./MIN. displacement	cm3/r	0 - 71
MAX. flow rate	l/mn	210
Working pressure	bar	500
Boost pump		
Capacity	cm3/r	19,6
MAX. flow rate	l/mn	58
Boost pressure MAX. R.P.M.	bar	30
Front wheel hydrostatic motor		REXROTH
Type		A2FE28/61W with fixed capacity
MAX. displacement	cm3/r	28
Front wheel reducer		BREVINI
Rear wheel hydrostatic motor		POCLAIN
Type		MS02 with fixed capacity
MAX. displacement	cm3/r	398
Drive wheels		4 RM Permanent
Switch for 2/4 drive wheels		No
Front tyres		MICHELIN
Size		280/80 R20 133A8 XMCL
Pressure	bar	4,4
Rear tyres		CONTINENTAL
Size		27.10-12 14PR IC30
Pressure	bar	7

ELECTRIC CIRCUIT		
Battery	Standard Option	12 V - 110 Ah - 750 A EN
Alternator		12 V - 70 A
Type		Denso 19279-64010
Starter		12 V - 2 kW
Type		17123-63010

BRAKE CIRCUIT		
Service brake		Low pressure hydraulic brake
Type of brake		Multidisc brake immersed in oil
Type of control		By foot on front wheels
Parking brake		Low pressure hydraulic brake
Type of brake		Multidisc brake immersed in oil
Type of control		Switch-operated electro-hydraulic

HYDRAULIC CIRCUIT		
Hydraulic pump		CASAPPA
Type		Gear pump
Capacity	cm ³	26
Max. rating capacity unladen	l/mn	77
Flow rate at 1800 rpm	l/mn	48
Filtration		
Return	µm	10
Suction	µm	100
Maximum service pressure		
Double mast with all-round vision	bar	170
Triple mast with free-acting lift	bar	180
Double mast with free-acting lift	bar	
Triple mast without free-acting lift	bar	180
Front/rear tilting circuit	bar	180/180
Attachment circuit	bar	180
Steering circuit	bar	125

HYDRAULIC MOVEMENTS		
Lifting movements		
Unladen lifting	m/s	0,6
Laden lifting	m/s	0,6
Unladen lowering	m/s	0,5
Laden lowering	m/s	0,6

SOUND AND VIBRATION		
Level of sound pressure in the driver's cab LpA (according to standard NF EN 12053)	dB	82
Level of sound power ensured in the LWA environment (according to directive 2000/14/EC modified by directive 2005/88/EC)	dB	measured/guaranteed
Average weighted acceleration on driver's body (according to standard NF EN 13059)	m/s ²	
The average weighted acceleration transmitted to the driver's hand/arm system (according to standard ISO 5349-2)	m/s ²	<2,5

SPECIFICATIONS AND WEIGHTS		
Speed of movement for lift truck in standard configuration on flat ground (except particular conditions)		
Front unladen	km/h	14
Rear unladen	km/h	
Standard mast		TSL 3M30
Lift height	mm	3300
Free lift height	mm	0
Overall height (retracted)	mm	1835
Overall height (extended)	mm	4070
Carriage		
Class		FEM2A
width	mm	1260
Weight of forks (each)	kg	43
Rated load capacity	kg	2500
Rated load capacity with standard mast	kg	2500
Effective load capacity on forks with side-shift carriage	kg	2400
Distance from the centre of gravity of the load to the base of the forks	mm	500
Lift truck weight without forks or mast	kg	3594
Lift truck weight with standard mast		
Unladen	kg	4340
At rated load	kg	6840
Axle weight with standard mast (transport position)		
Front unladen	kg	1870
Rear unladen	kg	2470
Front rated load	kg	5620
Rear rated load	kg	1220
Drag strain on the coupling hook		
Unladen (sliding)	daN	2300
At rated load (transmission setting)	daN	3500
Pull strain with open carrier (according to standard ISO 8313)	daN	

CHARACTERISTICS OF MASTS WITH ROLLERS

MSI 20 T Série 2-E3

MSI 20 T BUGGIE Série 2-E3

MSI 25 T Série 2-E3

MSI 25 T BUGGIE Série 2-E3

DOUBLE MAST WITH ALL-ROUND VISION							
MAST	HL	Z	Y	LL	H	H1	H2
3m00	3030	10°	12°	130	2150	3831	241
3m30	3330	10°	12°	130	2300	4131	241
3m50	3530	10°	12°	130	2400	4331	241
3m70	3730	10°	12°	130	2560	4531	181
4m00	4030	10°	12°	130	2750	4831	141
4m50	4530	10°	12°	130	3000	5331	141
5m00	5030	6°	6°	130	3250	5831	141
5m50	5530	6°	6°	130	3500	6331	141
6m00	6030	6°	6°	130	3790	6831	101

DOUBLE MAST WITH TOTAL FREE-ACTING LIFT							
MAST	HL	Z	Y	LL	H	H1	H2
3m00	3040	10°	12°	1393	2150	3797	147
3m30	3340	10°	12°	1543	2300	4097	147
3m50	3540	10°	12°	1643	2400	4297	147
3m70	3740	10°	12°	1803	2560	4497	147
4m00	4040	10°	12°	1993	2750	4797	147
4m50	4540	10°	12°	2243	3000	5297	147

TRIPLE MAST WITH TOTAL FREE-ACTING LIFT							
MAST	HL	Z	Y	LL	H	H1	H2
3m70	3740	10°	12°	1221	1950	4469	49
4m00	4040	10°	12°	1321	2050	4769	49
4m30	4340	10°	12°	1421	2150	5069	49
4m70	4740	10°	12°	1571	2300	5469	49
5m00	5040	6°	6°	1671	2400	5769	49
5m50	5540	6°	6°	1831	2560	6269	49
6m00	6040	6°	6°	2021	2750	6769	49
6m50	6540	6°	6°	2271	3000	7269	49
7m00	7040	6°	6°	2521	3250	7769	49

TRIPLE MAST WITHOUT FREE-ACTING LIFT							
MAST	HL	Z	Y	LL	H	H1	H2
3m30	3340	10°	12°	0	1840	4070	30

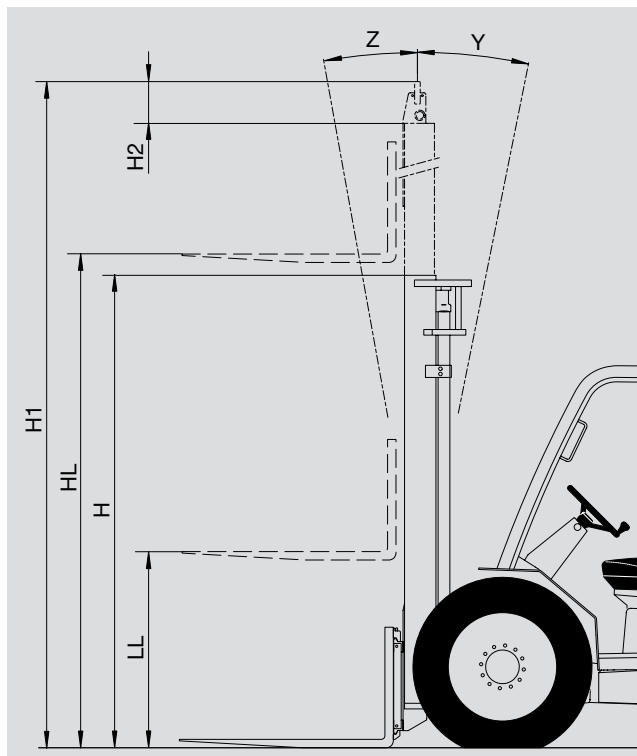

- HL : Lift height in mm
- Z : Forward tilting
- Y : Backward tilting
- LL : Free-acting lift in mm
- H : Overall height with folded mast in mm
- H1 : Overall height with spreaded out mast in mm
- H2 : Carriage overshooting in mm

CHARACTERISTICS OF MASTS WITH ROLLERS

MSI 30 T Série 2-E3

MSI 30 T BUGGIE Série 2-E3

MSI 35 T Série 2-E3

MSI 35 T BUGGIE Série 2-E3

DOUBLE MAST WITH ALL-ROUND VISION							
MAST	HL	Z	Y	LL	H	H1	H2
3m00	3035	10°	12°	135	2150	3893	298
3m30	3335	10°	12°	135	2300	4193	298
3m50	3535	10°	12°	135	2400	4393	298
3m70	3735	10°	12°	135	2560	4593	238
4m00	4035	10°	12°	135	2750	4893	198
4m50	4535	10°	12°	135	3000	5393	198
5m00	5035	6°	6°	135	3250	5893	198
5m50	5535	6°	6°	135	3500	6393	198
6m00	6035	6°	6°	135	3790	6893	158

DOUBLE MAST WITH TOTAL FREE-ACTING LIFT							
MAST	HL	Z	Y	LL	H	H1	H2
3m00	3045	10°	12°	1396	2150	3799	159
3m30	3345	10°	12°	1546	2300	4099	159
3m50	3545	10°	12°	1646	2400	4299	159
3m70	3745	10°	12°	1806	2560	4499	159
4m00	4045	10°	12°	1996	2750	4799	159
4m50	4545	10°	12°	2246	3000	5299	159

TRIPLE MAST WITH TOTAL FREE-ACTING LIFT							
MAST	HL	Z	Y	LL	H	H1	H2
3m70	3745	10°	12°	1297	2050	4500	38
4m00	4045	10°	12°	1397	2150	4800	38
4m30	4345	10°	12°	1547	2300	5100	38
4m70	4745	10°	12°	1647	2400	5500	38
5m00	5045	6°	6°	1807	2560	5800	38
5m50	5545	6°	6°	1997	2750	6300	38
6m00	6045	6°	6°	2247	3000	6800	38
6m50	6545	6°	6°	2497	3250	7300	38
7m00	7045	6°	6°	2747	3500	7800	38

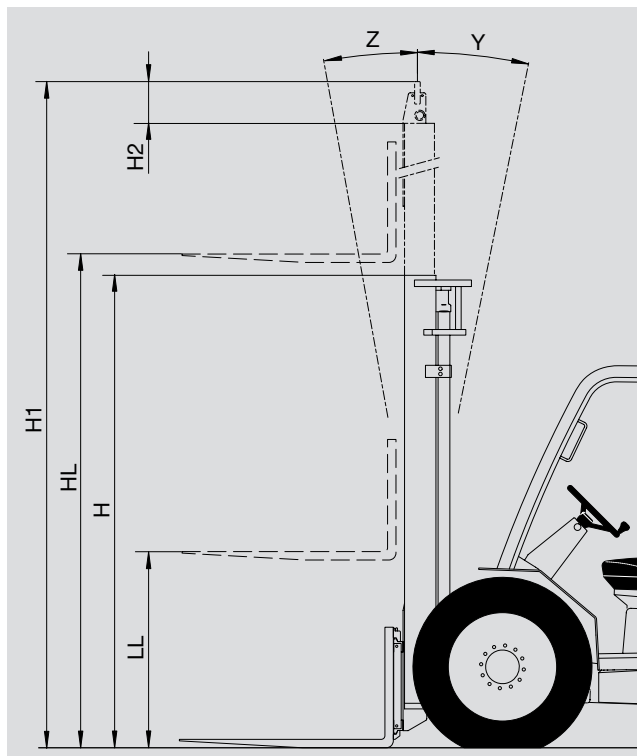

- HL : Lift height in mm
- Z : Forward tilting
- Y : Backward tilting
- LL : Free-acting lift in mm
- H : Overall height with folded mast in mm
- H1 : Overall height with spreaded out mast in mm
- H2 : Carriage overshooting in mm

CHARACTERISTICS OF MASTS WITH ROLLERS

MH 20-4 T BUGGIE Série 2-E3

MH 25-4 T BUGGIE Série 2-E3

DOUBLE MAST WITH ALL-ROUND VISION							
MAST	HL	Z	Y	LL	H	H1	H2
2m70	2730	10°	12°	130	1995	3531	246
3m00	3030	10°	12°	130	2145	3831	246
3m30	3330	10°	12°	130	2295	4131	246
3m50	3530	10°	12°	130	2395	4331	246
3m70	3730	10°	12°	130	2555	4531	186
4m00	4030	10°	12°	130	2745	4831	146
4m50	4530	10°	12°	130	2995	5331	146

DOUBLE MAST WITH TOTAL FREE-ACTING LIFT							
MAST	HL	Z	Y	LL	H	H1	H2
3m00	3040	10°	12°	1388	2145	3797	152
3m30	3340	10°	12°	1538	2295	4097	152
3m50	3540	10°	12°	1638	2395	4297	152
3m70	3730	10°	12°	1798	2555	4497	152
4m00	4040	10°	12°	1988	2745	4797	152
4m50	4540	10°	12°	2238	2995	5297	152

TRIPLE MAST WITH TOTAL FREE-ACTING LIFT							
MAST	HL	Z	Y	LL	H	H1	H2
3m70	3740	10°	12°	1216	1945	4469	54
4m00	4040	10°	12°	1316	2045	4769	54
4m30	4340	10°	12°	1416	2145	5069	54
4m70	4740	10°	12°	1566	2295	5469	54

TRIPLE MAST WITHOUT FREE-ACTING LIFT							
MAST	HL	Z	Y	LL	H	H1	H2
3m30	3340	10°	12°	0	1835	4070	35

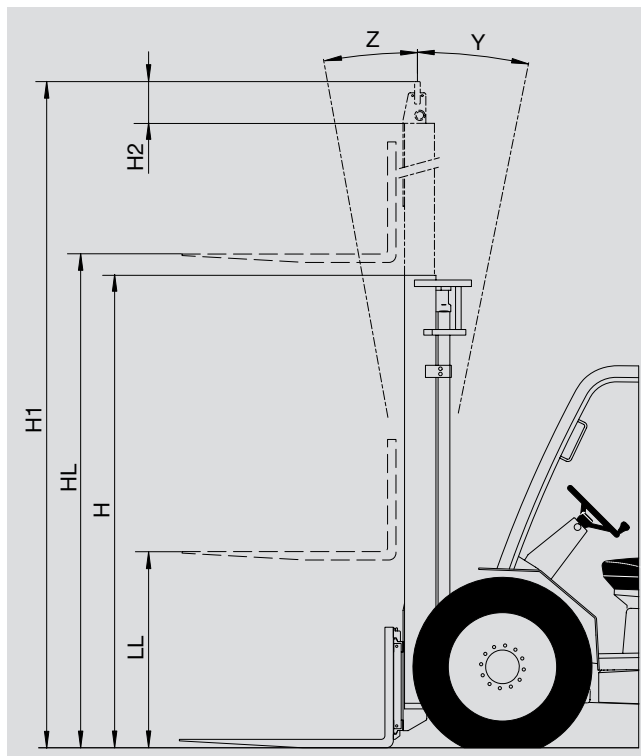

- HL : Lift height in mm
- Z : Forward tilting
- Y : Backward tilting
- LL : Free-acting lift in mm
- H : Overall height with folded mast in mm
- H1 : Overall height with spreaded out mast in mm
- H2 : Carriage overshooting in mm

FRONT AND REAR TIRES

FRONT		PRESSURE (bar)	TYRE LOAD (kg)	MSI 20 T Série 2-E3 MSI 20 T BUGGIE Série 2-E3		MSI 25 T Série 2-E3 MSI 25 T BUGGIE Série 2-E3		MSI 30 T Série 2-E3 MSI 30 T BUGGIE Série 2-E3		MSI 35 T Série 2-E3 MSI 35 T BUGGIE Série 2-E3		MH 20-4 T BUGGIE Série 2-E3	MH 25-4 T BUGGIE Série 2-E3
CONTINENTAL	10,5R20 14PR MPT80 134G TUBELESS	PRESSURE	4,4	5,3	5,6	6,5	4,4	5,3					
		Front unladen	850	800	950	850	900	850					
		Front laden	2450	2850	3400	3700	2550	2900					
	8,25X20 CSE SC15	PRESSURE	Plein	Plein	Plein	Plein							
		Front unladen	850	800	950	850							
		Front laden	2450	2850	3400	3700							
DUNLOP	15,5/55R18 14PR SPPG7 TUBELESS	PRESSURE	3,3	4	4,5	5,5	3,5	4					
		Front unladen	850	800	950	850	900	850					
		Front laden	2450	2850	3400	3700	2550	2900					
	12,0-18 T86 TUBE TYPE 12PR	PRESSURE	3,5	3,5	4,2								
		Front unladen	850	800	950								
		Front laden	2450	2850	3400								
GOODYEAR	275/70R22,5 RHS 148/145M TUBELESS	PRESSURE	9	9	9	9							
		Front unladen	850	800	950	850							
		Front laden	2450	2850	3400	3700							
MICHELIN	280/80R20 XMCL TUBELESS	PRESSURE	4,1	4,4			4,1	4,4					
		Front unladen	850	800			900	850					
		Front laden	2450	2850			2550	2900					

REAR		PRESSURE (bar)	TYRE LOAD (kg)	MSI 20 T Série 2-E3 MSI 20 T BUGGIE Série 2-E3		MSI 25 T Série 2-E3 MSI 25 T BUGGIE Série 2-E3		MSI 30 T Série 2-E3 MSI 30 T BUGGIE Série 2-E3		MSI 35 T Série 2-E3 MSI 35 T BUGGIE Série 2-E3		MH 20-4 T BUGGIE Série 2-E3	MH 25-4 T BUGGIE Série 2-E3
CONTINENTAL	7.00X12 14PR IC40	PRESSURE	4,5	5,3	6,7	7,5							
		Front unladen	1050	1200	1400	1550							
		Front laden	450	450	450	450							
	27.10.12 14PR IC12	PRESSURE	4,5	4,5	4,5	4,5							
		Front unladen	1050	1200	1400	1550							
		Front laden	450	450	450	450							
	27.10.12 14PR IC30	PRESSURE									7	7	
		Front unladen									1050	1250	
		Front laden									450	450	
	7.00X12 CSE SC10	PRESSURE	Plein	Plein	Plein	Plein							
		Front unladen	1050	1200	1400	1550							
		Front laden	450	450	450	450							
DUNLOP	195R14C 106/104N SPLT3 TUBELESS	PRESSURE	5,8										
		Front unladen	1050										
		Front laden	450										
MICHELIN	7.00R12 XZM 136A5 TUBELESS	PRESSURE	3,5	4	4,75	7							
		Front unladen	1050	1200	1400	1550							
		Front laden	450	450	450	450							

		PRESSURE (bar)	LOAD (kg)	PRESSURE ON THE CONTACT SURFACE (kg/cm2)		AREA OF THE CONTACT SURFACE (cm2)	
				HARD SOIL	LOOSE SOIL	HARD SOIL	LOOSE SOIL
CONTINENTAL	10,5R20 14PR MPT80 134G TUBELESS	4,4	850				
			900				
			2450				
			2550				
		5,3	800				
			850				
			2850				
		5,6	950				
			3400	5,40		630	
		6,5	850				
			3700				
		8,25X20 CSE SC15	Plein	800	3,27		259
	850			3,37		263	
	950			3,56		270	
	2450			6,51		372	
	2850			7,24		393	
	3400			8,19		415	
	7.00X12 14PR IC40	4,5	450				
			1050				
		5,3	450				
			1200				
		6,7	450				
			1400				
	7,5	450					
		1550					
	27.10.12 14PR IC12	4,5	450				
			1050				
			1200				
			1400				
	27.10.12 14PR IC30	7	450				
1050							
1250							
7.00X12 CSE SC10	Plein	450	3,80		119		
		1050	5,85		178		
		1200	6,30		190		
		1400	6,85		204		
DUNLOP	15,5/55R18 14PR SPPG7 TUBELESS	3,3	850	2,58	1,44	330	592
			2450	3,04	1,69	801	1442
		3,5	900				
			2550				
			800	2,87	1,59	280	504
		4	850	2,94	1,63	290	522
			2850	3,55	1,97	797	1434
			2900	3,57	1,98	810	1457
		4,5	950	3,27	1,82	290	522
			3400	3,95	2,20	860	1548
		5,5	850				
			3700				
	12,0-18 T86 TUBE TYPE 12PR	3,5	800	6,59	2,17	122	370
			850	6,76	2,22	126	383
			2450	9,12	3,08	266	786
			2850	9,58	3,27	297	872
		4,2	950	7,52	2,46	126	386
			3400	11,11	3,80	306	895
195R14C 106/104N SPLT3 TUBELESS	5,8	450					
		1050					

		PRESSURE (bar)	LOAD (kg)	PRESSURE ON THE CONTACT SURFACE (kg/cm ²)		AREA OF THE CONTACT SURFACE (cm ²)	
				HARD SOIL	LOOSE SOIL	HARD SOIL	LOOSE SOIL
GOODYEAR	275/70R22,5 RHS 148/145M TUBELESS	9	800				
			850				
			950				
			2450				
			2850				
			3400				
MICHELIN	280/80R20 XMCL TUBELESS	4,1	850				
			900				
			2450				
			2550				
		4,4	800				
			850				
	2850						
	7.00R12 XZM 136A5 TUBELESS	3,5	450	3,21		140	
			1050	3,25		323	
		4	450				
			1200				
		4,75	450	3,49		129	
			1400	4,73		296	
		7	450				
			1550				

DIMENSIONS AND LOAD CHART

MSI 20 T Série 2-E3

MSI 20 T BUGGIE Série 2-E3

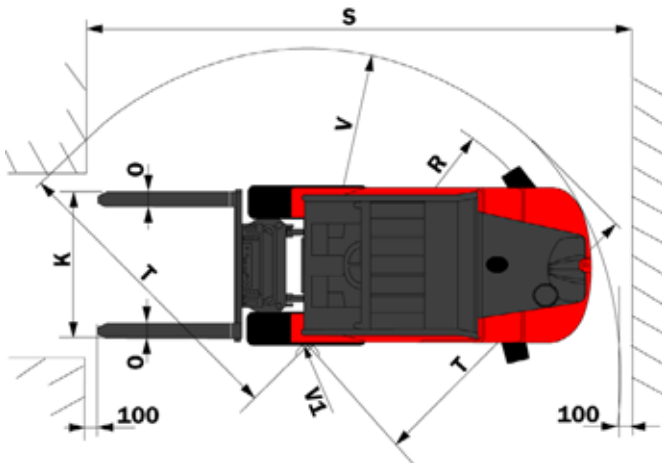
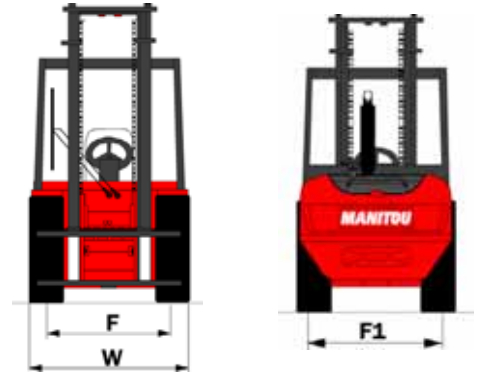
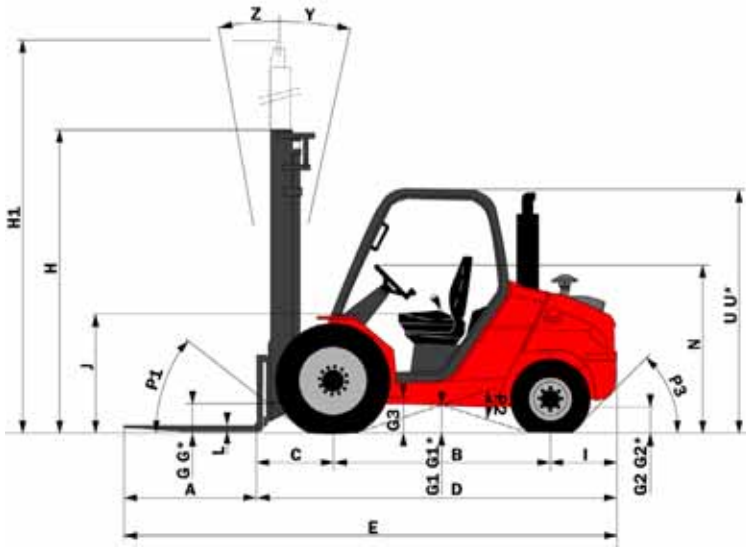

A	(mm)	1100
B	(mm)	1800
C	(mm)	625
D	(mm)	2945
E	(mm)	4045
F	(mm)	1046
F1	(mm)	1102
G	(mm)	270
G*	(mm)	240
G1	(mm)	260
G1*	(mm)	260
G2	(mm)	215
G2*	(mm)	230
G3	(mm)	270
H	(mm)	2300
H1	(mm)	4131
I	(mm)	520
J	(mm)	1025
K	(mm)	1260
L	(mm)	40
N	(mm)	1450
O	(mm)	100
P1	(°)	49,5
P2	(°)	40,5
P3	(°)	44
R	(mm)	2310
S	(mm)	4525
T	(mm)	2545
U	(mm)	2105
U*	(mm)	1990
V	(mm)	2600
V1	(mm)	150
W	(mm)	1323
Y	(°)	12
Z	(°)	10

RATED CAPACITY	CAPACITE NOMINALE RATED CAPACITY NENNKAPAZITÄT CAPACIDAD NOMINAL CAPACITÀ NOMINALE	2000 kg								
ACTUAL CAPACITIES (according to standard EN 1726-1)	CAPACITÉS EFFECTIVES ACTUAL CAPACITIES EFFEKTIVE KAPAZITÄT CAPACIDAD EFECTIVA CAPACITÀ EFFETTIVA	SUIVANT NORME EN 1726-1 (ISO 1074)								
1 - Up to height of	1 - Jusqu'à hauteur de levée Up to height of Bis zur Hubhöhe Hasta altura de elevación Sino ad altezza di sollevamento	- mm								
2 - For maximum height of	2 - Pour hauteur maximale de For maximum height of Für maximale Höhe Para altura máxima de Per altezza massima di	3300 mm								
VERTICAL MAST	MAT VERTICAL VERTICAL MAST VERTIKAL ES MAST MASTIL VERTICAL RAMPA VERTICALE	<table border="1"> <tbody> <tr> <td>D : kg</td> <td>2000</td> <td>1830</td> <td>1300</td> </tr> <tr> <td>D : mm</td> <td>500</td> <td>600</td> <td>1100</td> </tr> </tbody> </table>	D : kg	2000	1830	1300	D : mm	500	600	1100
D : kg	2000	1830	1300							
D : mm	500	600	1100							
ATTACHMENT	EQUIPEMENT ATTACHMENT ZUBEHÖR EQUIPO ATTREZZATURA	55F-SS-A931 55F-SS-A932 55F-SS-A933 -								
ACTUAL CAPACITIES	CAPACITÉS EFFECTIVES ACTUAL CAPACITIES EFFEKTIVE KAPAZITÄT CAPACIDAD EFECTIVA CAPACITÀ EFFETTIVA	<table border="1"> <tbody> <tr> <td>D : kg</td> <td>2000</td> <td>1830</td> <td>1300</td> </tr> <tr> <td>D : mm</td> <td>500</td> <td>600</td> <td>1100</td> </tr> </tbody> </table>	D : kg	2000	1830	1300	D : mm	500	600	1100
D : kg	2000	1830	1300							
D : mm	500	600	1100							

n°: 218115

G - G1 - G2 - G3 = Unladen

G* - G1* - G2* = Rated load

U = MSI 20 T Série 2-E3

U* = MSI 20 T BUGGIE Série 2-E3

DIMENSIONS AND LOAD CHART

MSI 25 T Série 2-E3

MSI 25 T BUGGIE Série 2-E3

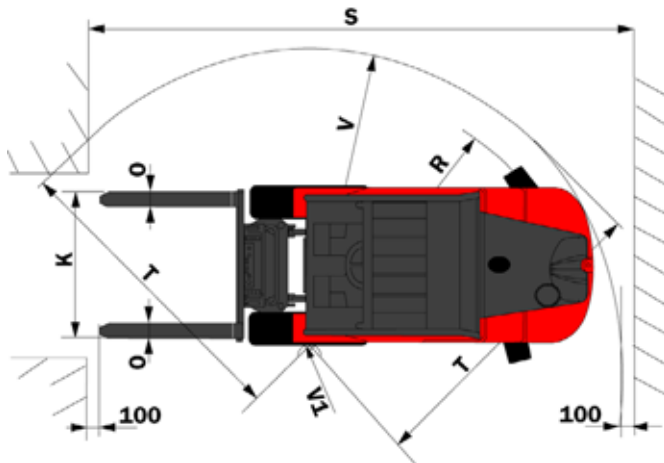
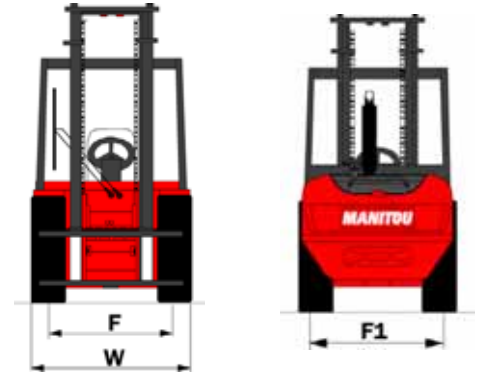
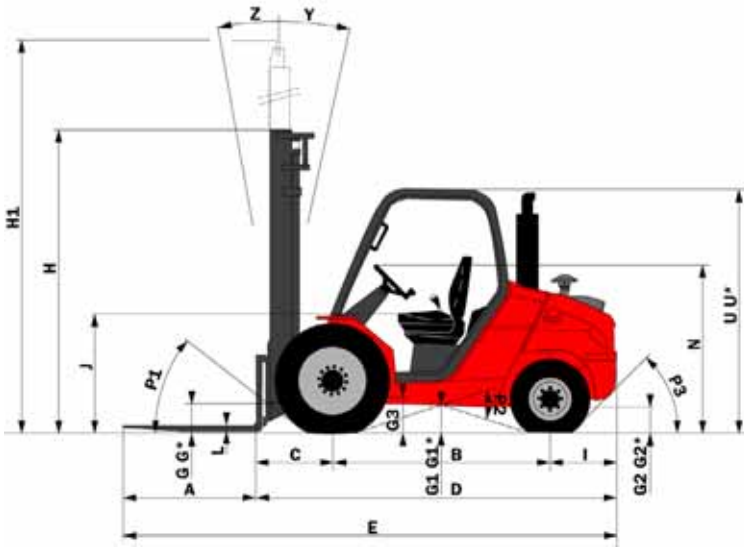

A	(mm)	1100
B	(mm)	1800
C	(mm)	625
D	(mm)	2945
E	(mm)	4045
F	(mm)	1046
F1	(mm)	1102
G	(mm)	270
G*	(mm)	240
G1	(mm)	260
G1*	(mm)	260
G2	(mm)	215
G2*	(mm)	230
G3	(mm)	270
H	(mm)	2300
H1	(mm)	4131
I	(mm)	520
J	(mm)	1025
K	(mm)	1260
L	(mm)	40
N	(mm)	1450
O	(mm)	100
P1	(°)	49,5
P2	(°)	40,5
P3	(°)	44
R	(mm)	2310
S	(mm)	4525
T	(mm)	2545
U	(mm)	2105
U*	(mm)	1990
V	(mm)	2600
V1	(mm)	150
W	(mm)	1323
Y	(°)	12
Z	(°)	10

RATED CAPACITY	CAPACITE NOMINALE RATED CAPACITY NENNKAPAZITÄT CAPACIDAD NOMINAL CAPACITÀ NOMINALE	2500 kg								
ACTUAL CAPACITIES (according to standard EN 1726-1)	CAPACITÉS EFFECTIVES ACTUAL CAPACITIES EFFEKTIVE KAPAZITÄT CAPACIDAD EFECTIVA CAPACITÀ EFFETTIVA	SUIVANT NORME EN 1726-1 (ISO 1074)								
1 - Up to height of	1 - Jusqu'à hauteur de levée Up to height of Bis zur Hubhöhe Hasta altura de elevación Sino ad altezza di sollevamento	- mm								
2 - For maximum height of	2 - Pour hauteur maximale de For maximum height of Für maximale Höhe Para altura máxima de Per altezza massima di	3300 mm								
VERTICAL MAST	MAT VERTICAL VERTICAL MAST VERTIKAL ES MAST MASTIL VERTICAL RAMPA VERTICALE	<table border="1"> <tr><td>D : kg</td><td>2500</td><td>2290</td><td>1630</td></tr> <tr><td>D : mm</td><td>500</td><td>600</td><td>1100</td></tr> </table>	D : kg	2500	2290	1630	D : mm	500	600	1100
D : kg	2500	2290	1630							
D : mm	500	600	1100							
ATTACHMENT	EQUIPMENT ATTACHMENT ZUBEHÖR EQUIPO ATTREZZATURA	55F-SS-A931 55F-SS-A932 55F-SS-A933 -								
ACTUAL CAPACITIES	CAPACITÉS EFFECTIVES ACTUAL CAPACITIES EFFEKTIVE KAPAZITÄT CAPACIDAD EFECTIVA CAPACITÀ EFFETTIVA	<table border="1"> <tr><td>1</td><td>-</td><td>-</td><td>-</td></tr> <tr><td>2</td><td>2500</td><td>2290</td><td>1630</td></tr> </table>	1	-	-	-	2	2500	2290	1630
1	-	-	-							
2	2500	2290	1630							
n°: 218136										

G - G1 - G2 - G3 = Unladen

G* - G1* - G2* = Rated load

U = MSI 25 T Série 2-E3

U* = MSI 25 T BUGGIE Série 2-E3

DIMENSIONS AND LOAD CHART

MSI 30 T Série 2-E3

MSI 30 T BUGGIE Série 2-E3

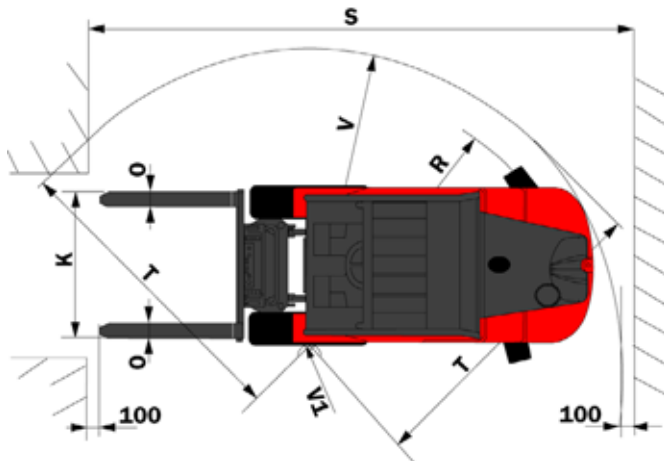
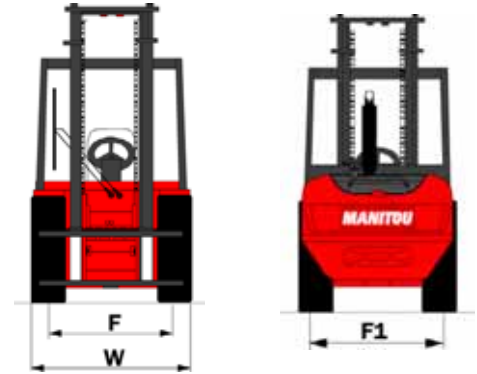
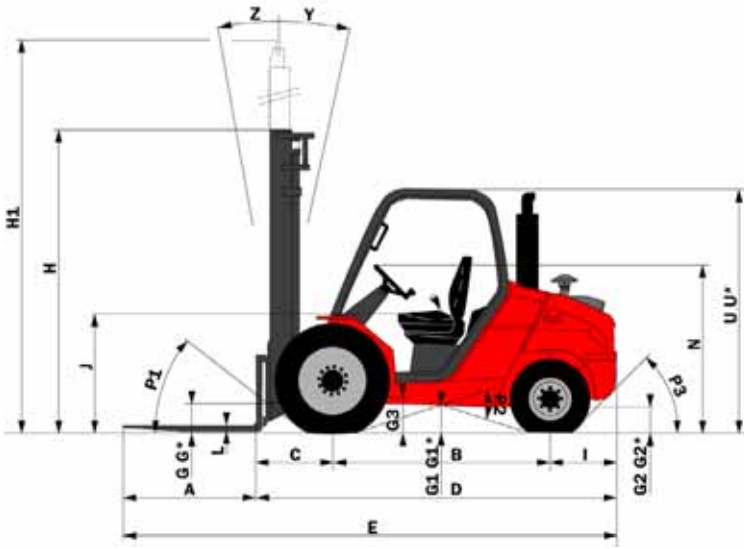

A	(mm)	1100
B	(mm)	1800
C	(mm)	630
D	(mm)	2980
E	(mm)	4080
F	(mm)	1046
F1	(mm)	1102
G	(mm)	270
G*	(mm)	240
G1	(mm)	260
G1*	(mm)	260
G2	(mm)	215
G2*	(mm)	230
G3	(mm)	270
H	(mm)	2300
H1	(mm)	4193
I	(mm)	550
J	(mm)	1025
K	(mm)	1260
L	(mm)	45
N	(mm)	1450
O	(mm)	100
P1	(°)	49,5
P2	(°)	40,5
P3	(°)	40
R	(mm)	2310
S	(mm)	4560
T	(mm)	2580
U	(mm)	2105
U*	(mm)	1990
V	(mm)	2635
V1	(mm)	150
W	(mm)	1323
Y	(°)	12
Z	(°)	10

RATED CAPACITY	<p>CAPACITE NOMINALE RATED CAPACITY NENNKAPAZITÄT CAPACIDAD NOMINAL CAPACITÀ NOMINALE</p> <p>3000 kg</p>
ACTUAL CAPACITIES (according to standard EN 1726-1)	<p>CAPACITÉS EFFECTIVES ACTUAL CAPACITIES EFFEKTIVE KAPAZITÄT CAPACIDAD EFECTIVA CAPACITÀ EFFETTIVA</p> <p>SUIVANT NORME EN 1726-1 (ISO 1074)</p>
1 - Up to height of	<p>1 - Jusqu'à hauteur de levée Up to height of Bis zur Hubhöhe Hasta altura de elevación Sino ad altezza di sollevamento</p> <p>- mm</p>
2 - For maximum height of	<p>2 - Pour hauteur maximale de For maximum height of Für maximale Höhe Para altura máxima de Per altezza massima di</p> <p>3300 mm</p>
VERTICAL MAST	<p>MAT VERTICAL VERTICAL MAST VERTIKALES MAST MASTIL VERTICAL RAMPA VERTICALE</p> <p>D : kg</p> <p>1 3000 2750 1960</p> <p>2 3000 2750 1960</p> <p>D : mm 500 600 1100</p>
ATTACHMENT	<p>EQUIPMENT ATTACHMENT ZUBEHÖR EQUIPO ATTREZZATURA</p> <p>60E-SS-B621 100E-SS-B551 100E-SS-B687</p>
ACTUAL CAPACITIES	<p>CAPACITÉS EFFECTIVES ACTUAL CAPACITIES EFFEKTIVE KAPAZITÄT CAPACIDAD EFECTIVA CAPACITÀ EFFETTIVA</p> <p>1 - 3000 2750 1960</p> <p>2 - 3000 2750 1960</p>
n°: 218157	

G - G1 - G2 - G3 = Unladen

G* - G1* - G2* = Rated load

U = MSI 30 T Série 2-E3

U* = MSI 30 T BUGGIE Série 2-E3

DIMENSIONS AND LOAD CHART

MSI 35 T Série 2-E3

MSI 35 T BUGGIE Série 2-E3

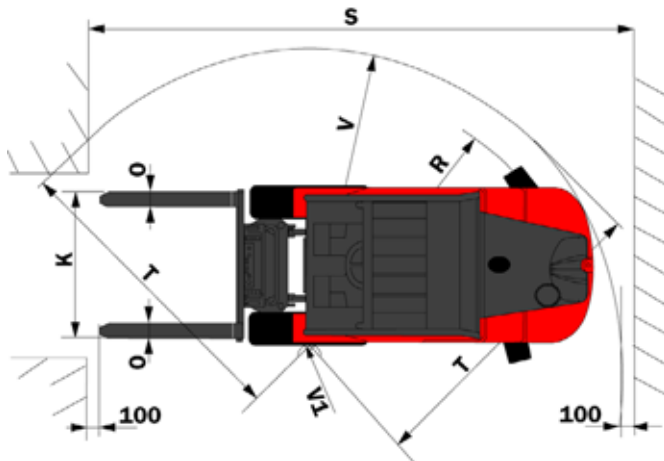
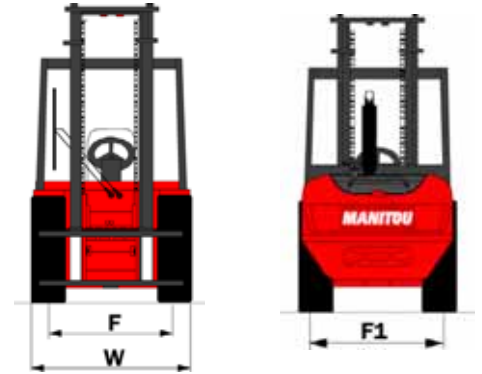
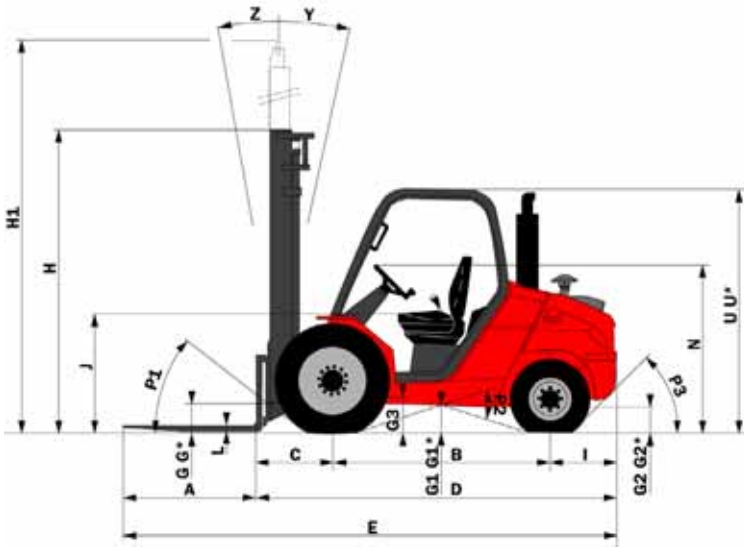

A	(mm)	1100
B	(mm)	1800
C	(mm)	630
D	(mm)	3030
E	(mm)	4130
F	(mm)	1046
F1	(mm)	1102
G	(mm)	270
G*	(mm)	240
G1	(mm)	260
G1*	(mm)	260
G2	(mm)	215
G2*	(mm)	230
G3	(mm)	270
H	(mm)	2300
H1	(mm)	4193
I	(mm)	600
J	(mm)	1025
K	(mm)	1260
L	(mm)	45
N	(mm)	1450
O	(mm)	125
P1	(°)	49,5
P2	(°)	40,5
P3	(°)	40
R	(mm)	2330
S	(mm)	4595
T	(mm)	2590
U	(mm)	2105
U*	(mm)	1990
V	(mm)	2665
V1	(mm)	100
W	(mm)	1323
Y	(°)	12
Z	(°)	10

RATED CAPACITY	<p>CAPACITE NOMINALE RATED CAPACITY NENNKAPAZITÄT CAPACIDAD NOMINAL CAPACITÀ NOMINALE</p> <p>3500 kg</p>
ACTUAL CAPACITIES (according to standard EN 1726-1)	<p>CAPACITÉS EFFECTIVES ACTUAL CAPACITIES EFFEKTIVE KAPAZITÄT CAPACIDAD EFECTIVA CAPACITÀ EFFETTIVA</p> <p>SUIVANT NORME EN 1726-1 (ISO 1074)</p>
1 - Up to height of	<p>1 - Jusqu'à hauteur de levée Up to height of Bis zur Hubhöhe Hasta altura de elevación Sino ad altezza di sollevamento</p> <p>- mm</p>
2 - For maximum height of	<p>2 - Pour hauteur maximale de For maximum height of Für maximale Höhe Para altura máxima de Per altezza massima di</p> <p>3300 mm</p>
VERTICAL MAST	<p>MAT VERTICAL VERTICAL MAST MASTIL VERTICAL RAMPA VERTICALE</p> <p>D : kg</p> <p>1 - 3500, 3210, 2280</p> <p>2 - 3500, 3210, 2280</p> <p>D : mm 500, 600, 1100</p>
ATTACHMENT	<p>EQUIPMENT ATTACHMENT ZUBEHÖR EQUIP ATTREZZATURA</p> <p>100E-SS-B554 100E-SS-B551 100E-SS-B687 -</p>
ACTUAL CAPACITIES	<p>CAPACITÉS EFFECTIVES ACTUAL CAPACITIES EFFEKTIVE KAPAZITÄT CAPACIDAD EFECTIVA CAPACITÀ EFFETTIVA</p> <p>1 - 3200, 2930, 2080</p> <p>2 - 3200, 2930, 2080</p>
n°: 242874	

G - G1 - G2 - G3 = Unladen

G* - G1* - G2* = Rated load

U = MSI 35 T Série 2-E3

U* = MSI 35 T BUGGIE Série 2-E3

DIMENSIONS AND LOAD CHART

MH 20-4 T BUGGIE Série 2-E3

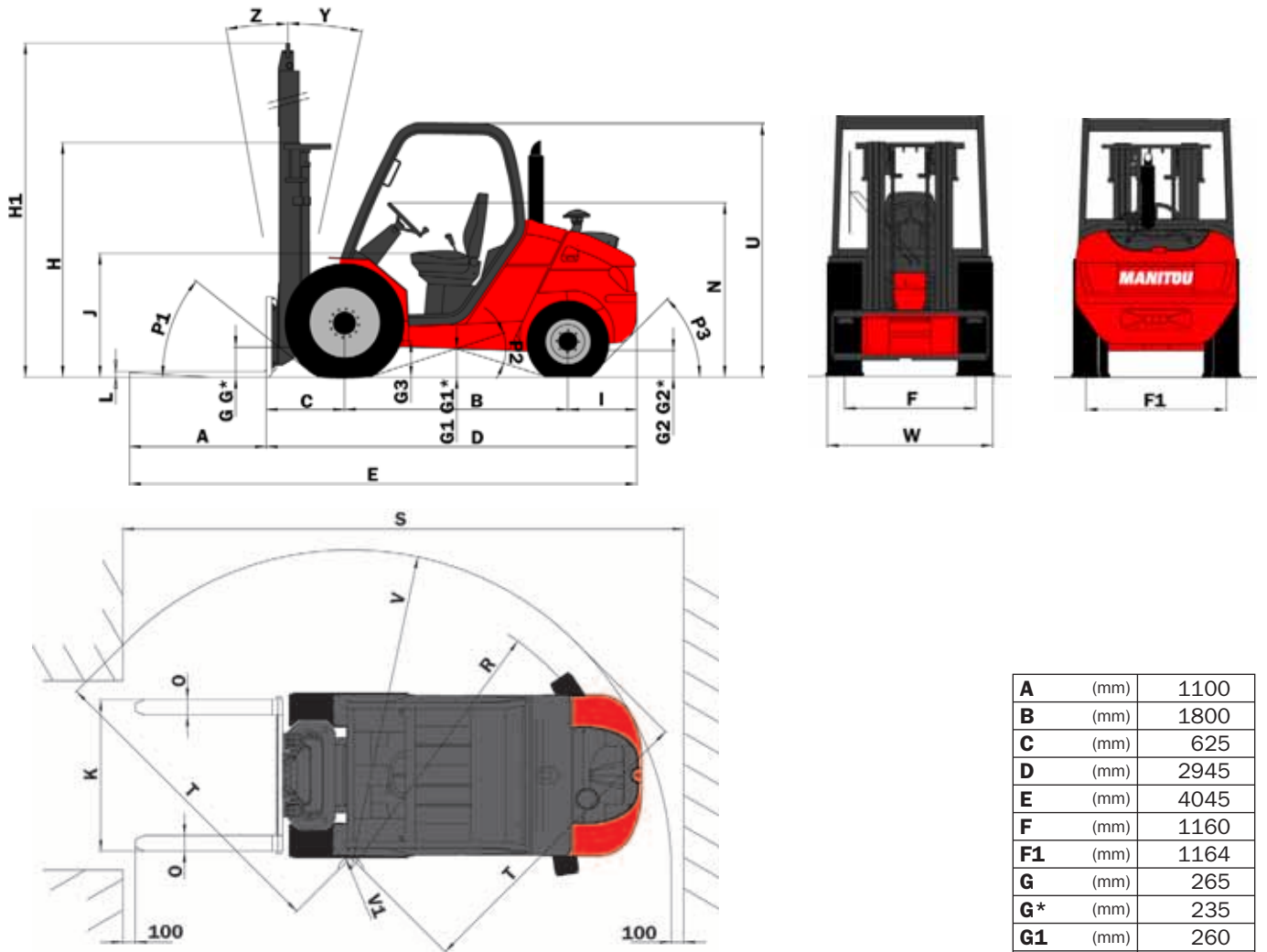

A	(mm)	1100
B	(mm)	1800
C	(mm)	625
D	(mm)	2945
E	(mm)	4045
F	(mm)	1160
F1	(mm)	1164
G	(mm)	265
G*	(mm)	235
G1	(mm)	260
G1*	(mm)	260
G2	(mm)	215
G2*	(mm)	230
G3	(mm)	270
H	(mm)	1835
H1	(mm)	4070
I	(mm)	520
J	(mm)	1025
K	(mm)	1260
L	(mm)	40
N	(mm)	1450
O	(mm)	100
P1	(°)	49,5
P2	(°)	40,5
P3	(°)	44
R	(mm)	3045
S	(mm)	5090
T	(mm)	2500
U	(mm)	1990
V	(mm)	3265
V1	(mm)	1080
W	(mm)	1450
Y	(°)	12
Z	(°)	10

ROUGH TERRAIN (1)

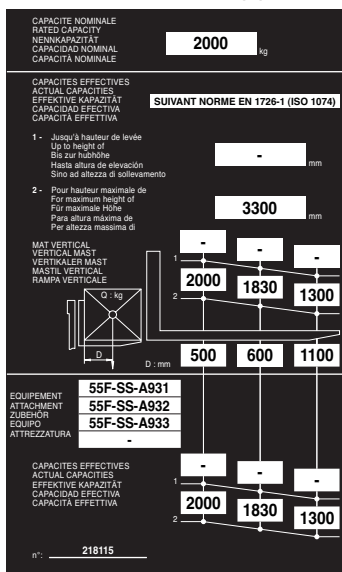

RATED CAPACITY

ACTUAL CAPACITIES
(according to standard EN 1726-1)

1 - Up to height of

2 - For maximum height of

VERTICAL MAST

ATTACHMENT

ACTUAL CAPACITIES

INDUSTRIAL FLOOR (2)

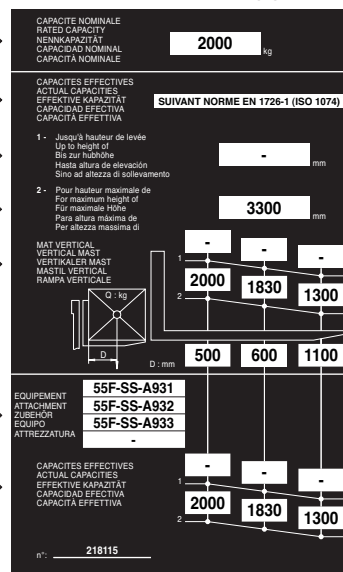

(1) The «rough terrain» load chart (according to EN 1726-1 appendix H) for use on natural, undeveloped, unlevelled ground or on construction sites.

(2) The «industrial floor» load chart (according to EN 1726-1 ISO 1074) for use on firm, smooth, flat and prepared surfaces.

G - G1 - G2 - G3 = Unladen
G* - G1* - G2* = Rated load

DIMENSIONS AND LOAD CHART

MH 25-4 T BUGGIE Série 2-E3

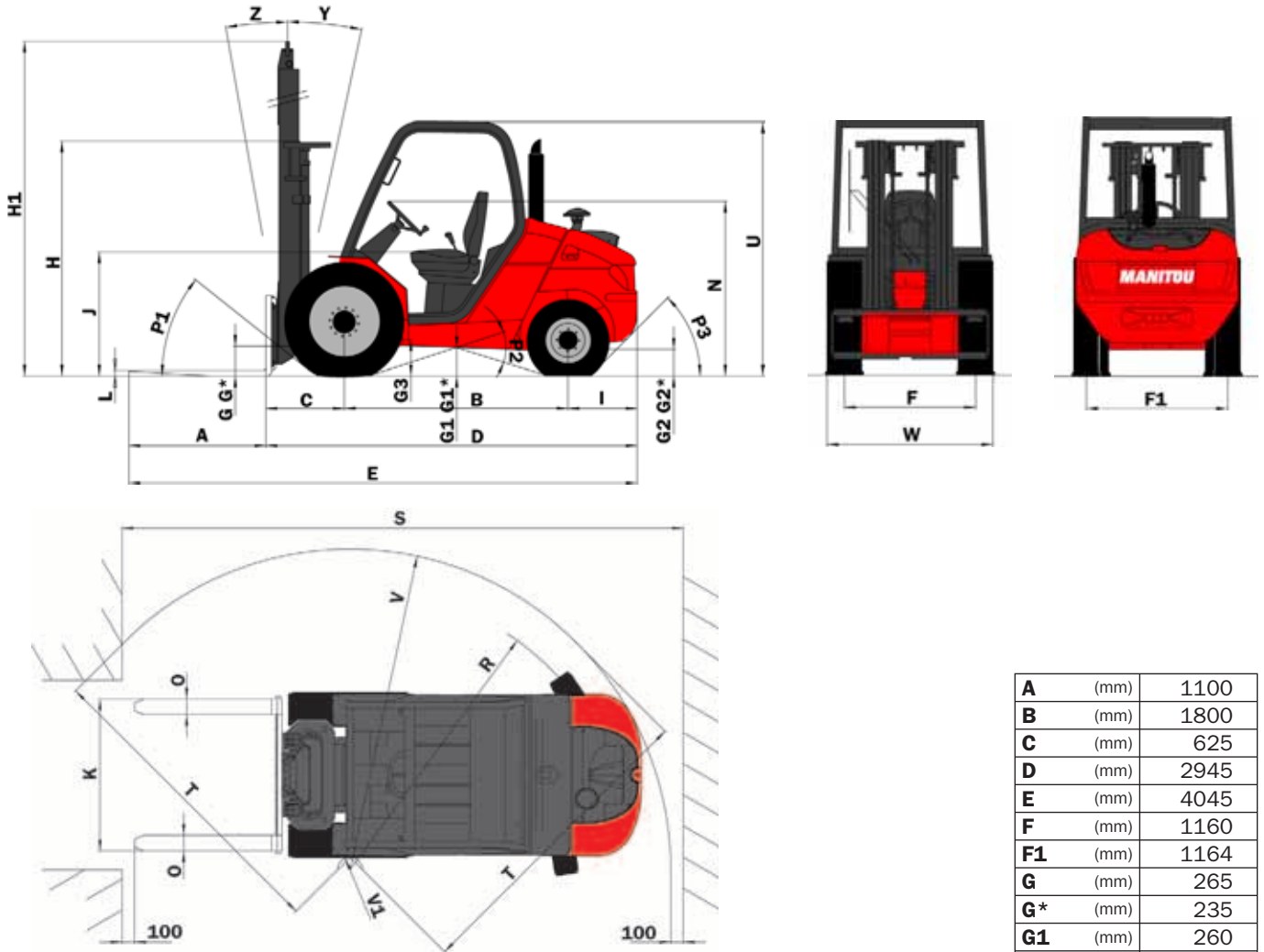

A	(mm)	1100
B	(mm)	1800
C	(mm)	625
D	(mm)	2945
E	(mm)	4045
F	(mm)	1160
F1	(mm)	1164
G	(mm)	265
G*	(mm)	235
G1	(mm)	260
G1*	(mm)	260
G2	(mm)	215
G2*	(mm)	230
G3	(mm)	270
H	(mm)	1835
H1	(mm)	4070
I	(mm)	520
J	(mm)	1025
K	(mm)	1260
L	(mm)	40
N	(mm)	1450
O	(mm)	100
P1	(°)	49,5
P2	(°)	40,5
P3	(°)	44
R	(mm)	3045
S	(mm)	5090
T	(mm)	2500
U	(mm)	1990
V	(mm)	3265
V1	(mm)	1080
W	(mm)	1450
Y	(°)	12
Z	(°)	10

ROUGH TERRAIN (1)

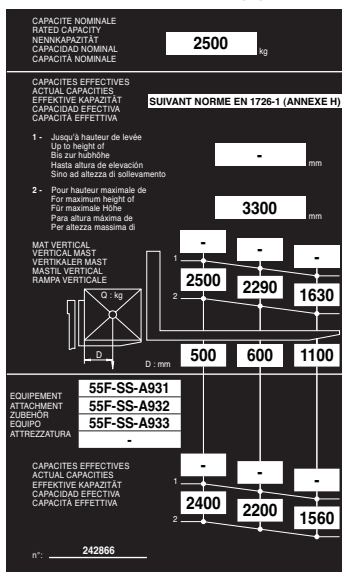

RATED CAPACITY

ACTUAL CAPACITIES
(according to standard EN 1726-1)

1 - Up to height of

2 - For maximum height of

VERTICAL MAST

ATTACHMENT

ACTUAL CAPACITIES

INDUSTRIAL FLOOR (2)

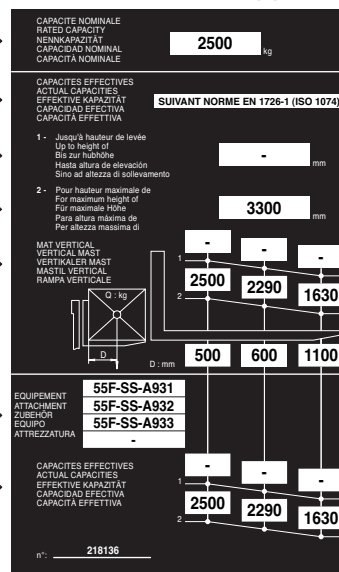

(1) The «rough terrain» load chart (according to EN 1726-1 appendix H) for use on natural, undeveloped, unlevelled ground or on construction sites.

(2) The «industrial floor» load chart (according to EN 1726-1 ISO 1074) for use on firm, smooth, flat and prepared surfaces.

G - G1 - G2 - G3 = Unladen
G* - G1* - G2* = Rated load

INSTRUMENTS AND CONTROLS

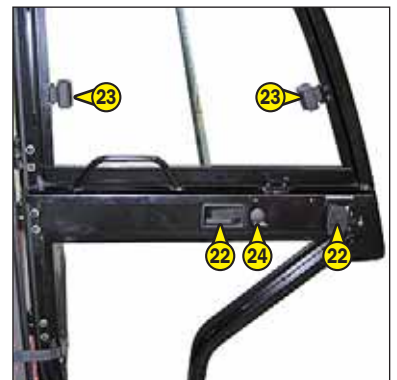
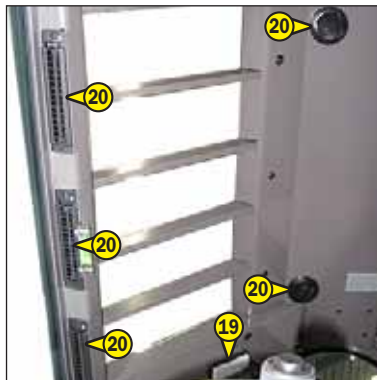

DESCRIPTION

- 1 - DRIVER'S SEAT**
- 2 - SAFETY BELT**
- 3 - CONTROL AND SIGNAL LIGHTS PANEL**
- 4 - SWITCHES**
- 5 - HORN SWITCH**
- 6 - IGNITION SWITCH**
- 7 - BATTERY CUT-OFF**
- 8 - ACCELERATOR PEDAL**
- 9 - SERVICE BRAKE PEDAL AND TRANSMISSION CUT-OFF**
- 10 - FUSES AND RELAYS IN THE CAB**
- 11 - FUSES AND RELAYS UNDER THE CAB (NOT ILLUSTRATED)**
- 12 - FORWARD/NEUTRAL/REVERSE GEAR SELECTION**
- 13 - HYDRAULIC CONTROLS**
- 14 - DOCUMENT CLIP**
- 15 - DOCUMENT HOLDER NET**
- 16 - WINDSCREEN WASHER TANK**
- 17 - LEVEL INDICATOR**
- 18 - OVERHEAD GUARD LIFTING**
- 18 - CAB LIFTING (OPTION)**
- 19 - ROOF LIGHT (OPTION)**
- 20 - HEATING VENTS (OPTION)**
- 21 - HEATER CONTROL (OPTION)**
- 22 - DOOR LOCKS (OPTION)**
- 23 - LEFT SIDE WINDSCREEN OPENING HANDLES (OPTION)**
- 24 - LOCKING HANDLE FOR UPPER HALF DOOR (OPTION)**
- 25 - RELEASING BUTTON FOR UPPER HALF DOOR (OPTION)**
- 26 - STEERING WHEEL TILTING HANDLE (OPTION) (NOT ILLUSTRATED)**

NOTE: All the terms such as: RIGHT, LEFT, FRONT, REAR are meant for an observer seated on driver's seat and looking in front of him.

1 - DRIVER'S SEAT

DESIGNED FOR MAXIMUM COMFORT, THIS SEAT CAN BE ADJUSTED AS FOLLOWS.

LONGITUDINAL ADJUSTMENT

- Pull the locking lever 1 upwards.
- Slide the seat to the required position.
- Release the lever and ensure it returns to the lock position.

SEAT SUSPENSION ADJUSTMENT

- Pull and lift up the locking lever 2 so as to place it into one of these five positions.
 - Position A : Light-weight driver (50 kg).
 - Position B : Intermediate.
 - Position C : Middle-weight driver.
 - Position D : Intermediate.
 - Position E : Heavy-weight driver (120 kg).

ANGLE ADJUSTMENT OF THE BACK-REST

- Pull the locking lever 3 backwards.
- Tilt the back-rest into one of the three possible positions.
- Release the locking lever and ensure it returns to the lock position.

ANGLE ADJUSTMENT OF THE WHOLE SEAT

- Lift up the locking lever 4.
- Tilt the seat forwards or backwards.
- Release the lever and ensure it returns to the lock position.

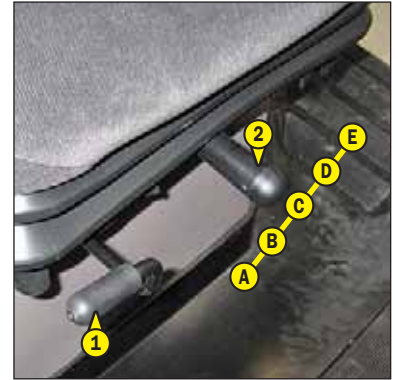

2 - SAÔFETY BELT

- Sit correctly on the seat.
- Check that seat belt is not twisted.
- Place the seat belt at hip level.
- Attach the seat belt and check that it locks.
- Adjust the seat belt to your body shape without squeezing your hip and without over-slack.

! *In no event should the lift truck be used if the seat belt is defective (fixing, locking, cuts, tears, etc.). Repair or replace the seat belt immediately.*

3 - CONTROL AND SIGNAL LIGHTS PANEL

CONTROL INSTRUMENTS

A - HOURMETER

B - FUEL LEVEL

Red zone B1 indicates that you are using the reserve supply and that time of use is limited.

SIGNAL LIGHTS

When activating the electrical system of the lift truck, all the red lamps and the panel's buzzer must light to indicate their good working order. If one of the red lamps or the buzzer does not function, carry out the necessary repairs.

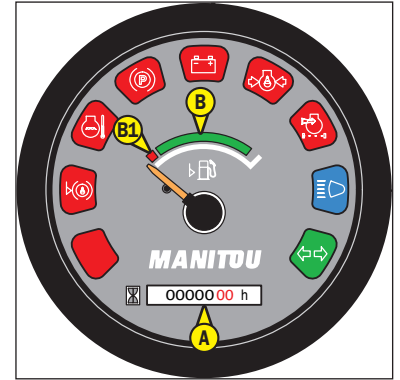

RED LAMP - HYDRAULIC RETURN FILTER CLOGGED

The lamp and buzzer come on when the hydraulic return oil filter cartridge is clogged up. Stop the lift truck and carry out the necessary repairs (see cleaning and replacement requirements in chapter: 3 - MAINTENANCE: FILTERS CARTRIDGES AND BELTS).

NOTE: This lamp comes on by cold weather or when starting the fork lift truck, it goes off when the hydraulic oil reach the temperature of functioning.



NOT USED



RED I.C. ENGINE WATER TEMPERATURE LAMP

If the lamp and the buzzer come on when the lift truck is running, stop the I.C. engine immediately and investigate the cooling circuit for the cause of the malfunction.



RED PARKING BRAKE LAMP

This lamp comes on when the parking brake is applied.



RED BATTERY CHARGE WARNING INDICATOR LIGHT

If the red lamps and the buzzer come on, when the lift truck is running, stop the I.C. engine immediately and check the electrical circuit as well as the alternator belt.



RED I.C. ENGINE OIL PRESSURE LAMP

If the lamp and the buzzer come on when the lift truck is running, stop the I.C. engine immediately and look for the cause (see oil level in I.C. engine crankcase).



K - RED AIR FILTER CLOGGING INDICATOR LAMP

The lamp and the buzzer come on when the air filter cartridge is clogged up. Stop the lift truck and carry out the necessary repairs (see cleaning and replacement requirements in chapter: 3 - MAINTENANCE: FILTERS CARTRIDGES AND BELTS).



BLUE MAIN BEAM LAMP (OPTION)



GREEN INDICATOR LAMP (OPTION)

4 - SWITCHES

NOTE: The location of the switches may vary depending on the options.

MSI 20 T Série 2-E3 + BUGGIE
MSI 25 T Série 2-E3 + BUGGIE
MSI 30 T Série 2-E3 + BUGGIE
MSI 35 T Série 2-E3 + BUGGIE

MH 20-4 Turbo Série 2-E3
MH 25-4 Turbo Série 2-E3

A - PARKING BRAKE

To connect the parking brake, lower the button 1 and press the bottom of the switch. The signal lamp shows it is being used. To disconnect the parking brake, press the top of the switch.

B - FRONT WINDSCREEN WIPER AND WINDSCREEN WASHER

This switch, when set to the "intermediate" position, the windscreen wiper to be operated and the "down" position and simultaneously pressed, the windscreen-washer to be operated.

C - REAR WINDSCREEN WIPER

D - WARNING LIGHTS OPTION

This switch enables the L.H. and R.H. Indicators to be switched on simultaneously, with the ignition off. The signal light indicates that the switch is being used.

E - OVERHEAD GUARD OR CAB LIFTING

See: 2 - DESCRIPTION: 18 - OVERHEAD GUARD LIFTING or 18 - CAB LIFTING (OPTION) for operation of the switch.

F - OPTION

MSI 20 T Série 2-E3 + BUGGIE MSI 25 T Série 2-E3 + BUGGIE
MSI 30 T Série 2-E3 + BUGGIE MSI 35 Turbo Série 2-E3 + BUGGIE

F - SPEED COMPENSATION ON THE 4 WHEELS

MH 20-4 Turbo Série 2-E3 MH 25-4 Turbo Série 2-E3

In the event of skidding, by holding this switch down in high position, the four drive wheels will turn at the same speed and hence improve drivability, no matter what the condition of the ground.



When the speed compensation on the 4 wheels is engaged, always drive in straight line and slowly.

G - FRONT WORK LIGHTS OPTION

H - REVOLVING LIGHT OPTION

I - REAR WORK LIGHTS OPTION

A - HEATING FAN OPTION

This two speed switch allows warm or cold air to pass through the heating ventilators.

K - ADDITIONAL OR LOW-LEVEL HEATING OPTION

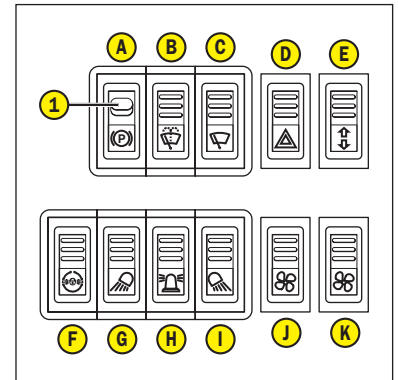
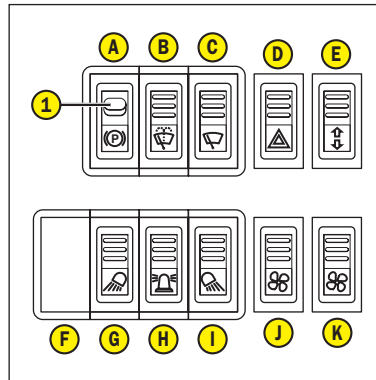

5 - HORN SWITCH

6 - IGNITION SWITCH

The key switch has five positions:

- P - Ignition off, parking position.
- O - Ignition switched off and I.C. engine stopped.
- I - Ignition on.
- II - Heating.
- III - The I.C. engine starts, return to position I as soon as the key is released.

7 - BATTERY CUT-OFF

Enables the battery to be rapidly cut off from the electric circuit in the event of a short circuit or a fire.

8 - ACCELERATOR PEDAL

9 - SERVICE BRAKE PEDAL AND TRANSMISSION CUT-OFF

This pedal operates in two steps:

- First, the pedal acts upon a hydraulic valve which progressively cuts off the hydrostatic transmission so as to carry out a slow approach with all the I.C. engine output.
- Then, the pedal acts upon a hydraulic valve which progressively makes the pressure in the brakes drop so as to immobilise the lift truck.

10 - FUSES AND RELAYS IN THE CAB

- Remove the casing to access fuses F1 to F24.

! Always replace a faulty fuse with another of equivalent rating. Never use a fuse that has been repaired.

- F1 - OPTION Light switch power supply, horn and indicators (15A).
- F2 - OPTION Hazard warning lights power supply (10A).
- F3 - Rear windscreen wiper (7.5A).
- F4 - Stop I.C. engine electrovalve (5A).
- F5 - OPTION 1 Front work light (7.5 A).
- OPTION 2 Front work lights (15A).
- F6 - OPTION Heating (15A).
- F7 - Control panel (5A).
- F8 - Front windscreen wiper and windscreen-washer (10A).
- F9 - OPTION Indicator power supply (10A).
- F10 - Reversing gear (10A).
- OPTION Reversing light (10A).
- OPTION Audible reversing alarm (10A).
- F11 - Parking brake (10A).
- Sound alarm (10A).
- OPTION stop switch (10A).
- F12 - OPTION Revolving light (7.5A).
- F13 - OPTION Right-hand sidelights (5A).
- F14 - OPTION Left-hand sidelights (5A).
- F15 - OPTION Right-hand indicators (7.5A).
- F16 - OPTION Left-hand indicators (7.5A).
- F17 - OPTION Dipped headlights (10A).
- F18 - OPTION Main headlights (10A).
- F19 - OPTION Roof light (3A).
- F20 - OPTION (+) permanent (3A).
- F21 - OPTION 1 Rear work light (7.5A).
- OPTION 2 Rear work lights (15A).
- F22 - Differential lock (5A). MH 20-4/25-4 Turbo BUGGIE Série 2-E3
- F23 - Starter (20A).
- F24 - Overhead guard or cab lifting (5A).

- Remove plate 1 to access relays K1 to K6 and B2.

- K1 - Safety system starting switch relay.
- K2 - OPTION Flashing unit.
- K3 - Reverse gear relay.
- K5 - Transmission cut-off relay.
- K6 - Forward gear relay.
- B2 - Buzzer.

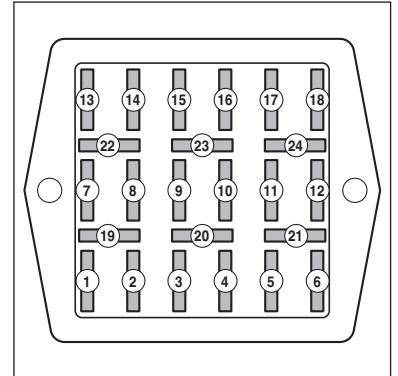

11 - FUSES AND RELAYS UNDER THE CAB

Remove cover 1 in order to gain access to the fuses.

! Always replace a faulty fuse with another of equivalent rating. Never use a fuse that has been repaired.

- F25 - Preheating I.C. engine (50A).
- F26 - Alternator (70A).
- F27 - Lift truck electrical equipment (70A).
- F28 - Overhead guard or cab lifting (50A).
- K7 - Preheating relay.
- OPTION diesel decongealant relay.
- OPTION diesel decongealant fuse (15A).

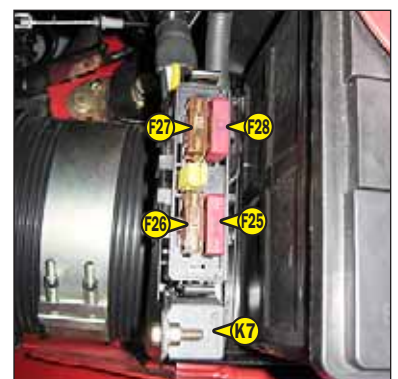

12 - FORWARD/NEUTRAL/REVERSE GEAR SELECTION

When operating this control, the lift truck should be travelling at slow speed and not accelerating. When the reverser is in the neutral position a mechanical lock prevents an accidental shifting movement.

FORWARD: Lift slightly and push the lever forwards (position A).

REVERSE: Lift slightly and pull the lever backwards (position B).

NEUTRAL: To start the lift truck, the lever must be in neutral (position C).

NOTE: As an OPTION, reversing lights and an acoustic reversing alarm indicate that the lift truck is running in reverse.

SAFETY FOR MOVING THE LIFT TRUCK

Authorisation to move the lift truck is controlled by an electronic unit. The operator must observe the following sequence to move the truck forwards or backwards:

- 1 - sit down correctly in the driver's seat,
- 2 - release the parking brake,
- 3 - engage forward or reverse movement.

To stop the lift truck, he must observe the following sequence:

- 1 - Set the forward/reverse selector to neutral,
- 2 - engage the parking brake,
- 3 - get out of the lift truck.

NOTE: If the operator leaves the driving cab with forward or reverse engaged, a continuous alarm will sound. While this alarm sounds, the operator can simply sit back in the seat and continue advancing or reversing.

If the alarm becomes discontinuous, the operator must sit back in the seat, put the forward/reverse selector back in neutral and select forward or reverse if he wishes to continue moving.

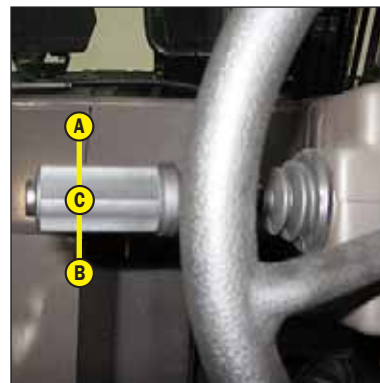

13 - HYDRAULIC CONTROLS

⚠ Do not attempt to alter the hydraulic system pressure by interfering with the pressure regulating valve. In the event of suspected malfunction, contact your dealer. ANY ALTERATION MAY RENDER THE WARRANTY NULL AND VOID.

⚠ Use the hydraulic controls carefully without jerking, to avoid accidents caused by shaking the lift truck.

LIFTING THE LOAD

- The lever A to the right when lifting.
- The lever A to the left when lowering.

NOTE: The engine r.p.m. automatically increases when lifting the load.

TILTING THE MAST

- The lever A backwards for backward tilting.
- The lever A forwards for forward tilting.

ATTACHMENT

- Lever B forward or backward.

ADDITIONAL ACCESSORY

- The lever C forwards or backwards.



14 - DOCUMENT CLIP

15 - DOCUMENT HOLDER NET

Make sure that the operator's manual is in the right place, i.e. in the document holder net.

NOTE: An OPTION waterproof document-holder exists.

16 - WINDSCREEN WASHER TANK

See: 3 - MAINTENANCE: B - EVERY 50 HOURS SERVICE.

17 - LEVEL INDICATOR

Enables the operator to check that the lift truck is in the horizontal position.



18 - OVERHEAD GUARD LIFTING

! Make sure that the mast is tilted forwards to a maximum and the engine is stopped before lifting the overhead guard.

UNLOCKING THE OVERHEAD GUARD

- Keep the ignition on in the lift truck.
- Unlock the overhead guard by means of the lever 1 (fig. A) in position A.

LIFTING THE OVERHEAD GUARD

- Press the top of the switch 2 (fig. B) until complete lifting of the overhead guard.
- Put the lever 1 back into position B (fig. C).
- Place the safety prop 3 onto its stop 4 (fig. D).

! Check that there is nothing laying on the driver's seat, which could disrupt the operation.

LOWERING THE OVERHEAD GUARD

- Fold the safety prop back into its clip 5 (fig. E).
- Lower the overhead guard into its initial position by pressing the bottom of the switch 2 (fig. B).
- Ensure that the overhead guard is locked.

! Check that nothing or nobody can impede the lowering of the overhead guard.

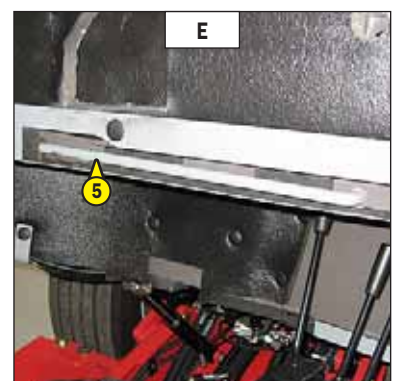
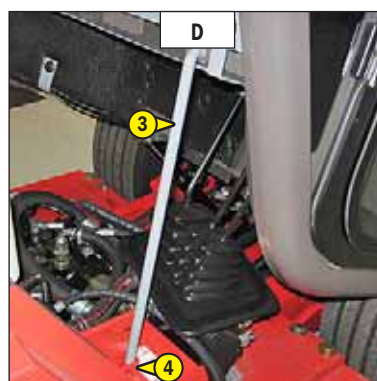
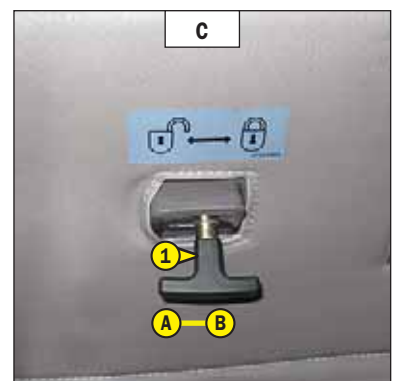
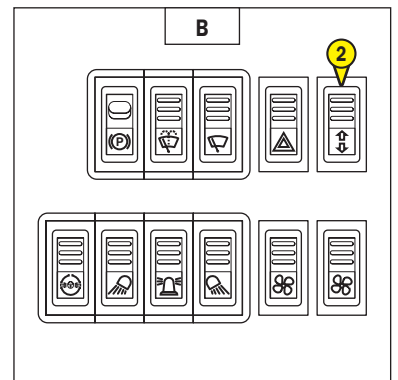
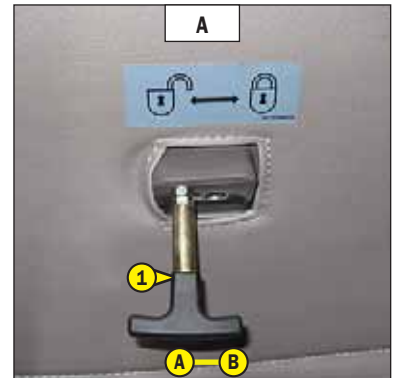

18 - CAB LIFTING (OPTION)

! Ensure that the mast is tilted forwards to a maximum, that the engine is stopped and that the two doors are shut before lifting the cab.

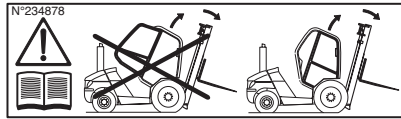

UNLOCKING THE CAB

- Half-open the right door of the cab.
- Keep the ignition on in the lift truck.
- Unlock the cab by means of the lever 1 (fig. A) in position A.

RAISING THE CAB

- Maintain the door half-open.
- Press the top of the switch 2 (fig. B) until complete lifting of the cab.
- Put the lever 1 back into position B (fig. C).
- Shut the door.
- Place the safety prop 3 (fig. C) onto its stop 4 (fig. D).

! Check that there is nothing laying on the driver's seat, which could disrupt the operation.

LOWERING THE CAB

- Fold the safety prop back into its clip 5 (fig. E).
- Half-open the right door of the cab.
- Lower the cab into its initial position by pressing the bottom of the switch 2 (fig. B).
- Ensure that the cab is locked.
- Shut the door.

! Check that nothing or nobody can impede the lowering of the cab.

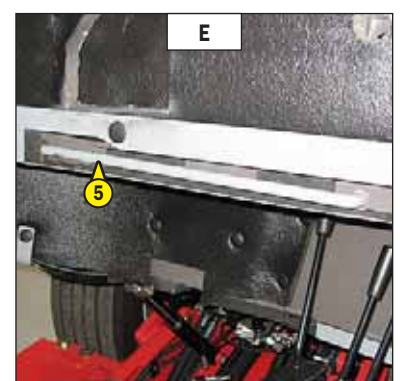
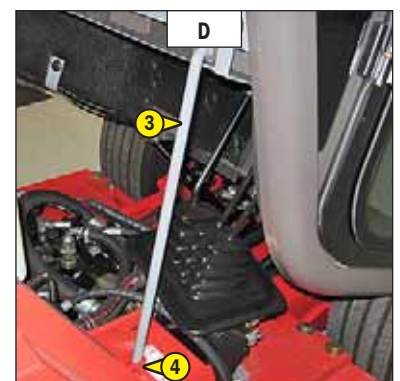
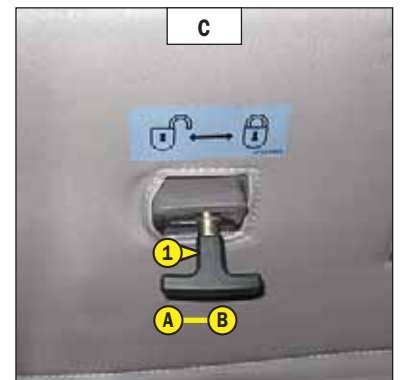
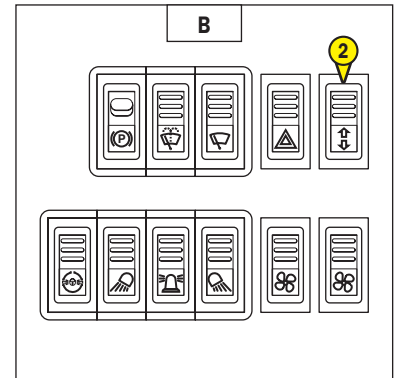
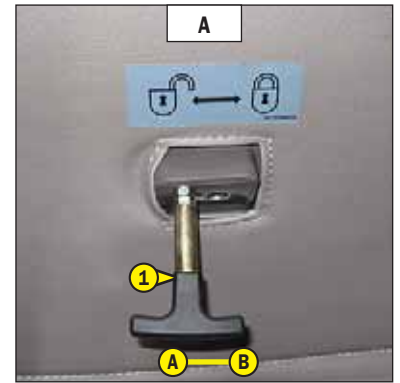

19 - ROOF LIGHT (OPTION)

20 - HEATING VENTS (OPTION)

21 - HEATER CONTROL (OPTION)

Allows the temperature inside the cab to be adjusted.
A - With the valve closed, the fan delivers fresh air.
B - With the valve opened completely, the fan delivers warm air.
The intermediate positions allow the temperature to be adjusted.

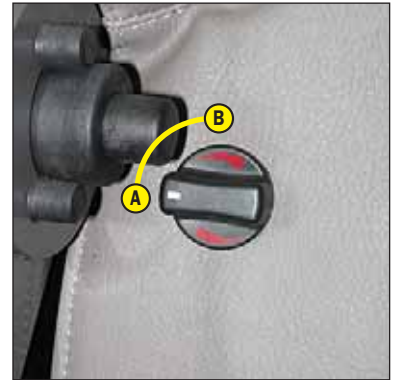

22 - DOORS LOCKS (OPTION)

Two keys are provided with the lift truck to enable the cabin to be locked.

23 - LEFT SIDE WINDSCREEN OPENING HANDLES (OPTION)

24 - LOCKING HANDLE FOR UPPER HALF DOOR (OPTION)

25 - RELEASING BUTTON FOR UPPER HALF DOOR (OPTION)

26 - STEERING WHEEL TILTING HANDLE (OPTION)

This handle enables the angle of the steering wheel to be adjusted.
- Turn handle 1 towards A to loosen and adjust steering wheel.
- Turn handle 1 towards B to lock steering wheel in the position required.



TOWING PIN AND HOOK

Located at the rear of the lift truck, this device is used to attach a trailer. Its capacity is limited for each lift truck by the authorised gross vehicle weight, tractive effort and maximum vertical force on the coupling point. This information is given on the manufacturer's plate fixed to each lift truck (see : 2 - DESCRIPTION : IDENTIFICATION OF THE LIFT TRUCK).

- To use a trailer, see current regulations in your country (maximum running speed, braking, maximum weight of trailer, etc.).
- Verify the trailer's condition before using it (tyre condition and pressures, electrical connection, hydraulic hose, braking system...).

⚠ Do not tow a trailer or accessory which is not in perfect working order. Using a trailer in poor condition may effect the lift truck's steering and braking, and hence safety.

⚠ If a third party helps in coupling or uncoupling the trailer, this person must be permanently visible to the driver and wait until the lift truck has stopped, the handbrake is on and the I.C. engine is switched off before performing the operation.

A - TOWING PIN

COUPLING AND UNCOUPLING THE TRAILER

- To couple the trailer, position the lift truck as close as possible to the trailer ring.
- Put the handbrake on and switch off the I.C. engine.
- Remove the clip 1, lift the trailer pin 2 and place or remove the trailer ring.

⚠ Be careful not to get your fingers caught or crushed during this operation.
Do not forget to put clip 1 back in place.
When uncoupling, make sure that the trailer is supported independently.



DESCRIPTION AND USE OF ELECTRIC AND HYDRAULIC OPTIONS

1 - REVOLVING LIGHT

The revolving light is dismantlable to make it possible, for example, to reduce the bulkiness of the lift truck or to avoid being stolen.

- Loosen nut 1 and remove the revolving light.
- Protect mounting 2 with cap 3.

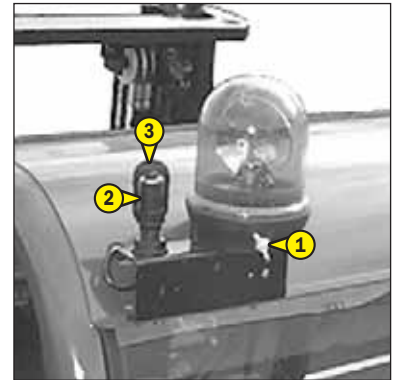

2 - LIGHT SWITCH, HORN AND INDICATOR SWITCH

The switch controls the visual and sound alarms.

- A - All lights are off, the direction indicators do not flash.
- B - The right hand direction indicators flash.
- C - The left hand direction indicators flash.
- D - The sidelights and the rear lights are on.
- E - The dipped headlights and the rear lights are on.
- F - The main beam headlights and the rear lights are on.
- G - Headlight signal.

Pressing the switch sounds the horn.

NOTE : The positions D - E - F - G can be carried out without the ignition being on.

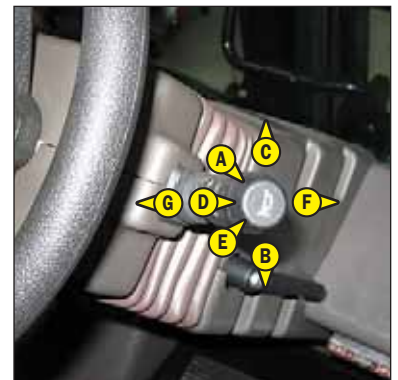

3 - FRONT LIGHTS

- A - Left front indicator.
- B - Left front sidelight.
- C - Left front dipped headlight and main beam.
- D - Right front sidelight.
- E - Right front dipped headlight and main beam.
- F - Right front indicator.



4 - REAR LIGHTS (OVERHEAD GUARD MODEL)

- A - Left rear indicator.
- B - Left tail light.
- C - Left rear stoplight.
- D - Right rear stoplight.
- E - Right tail light.
- F - Right rear indicator.

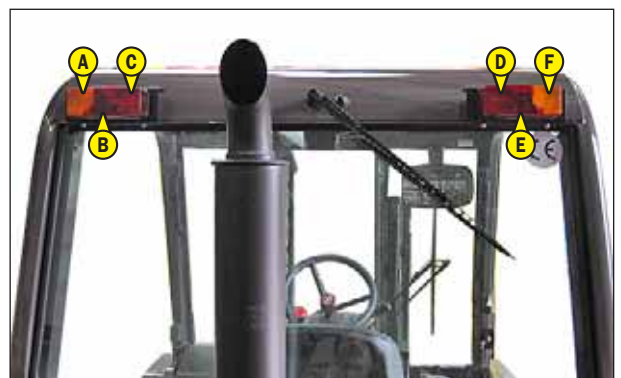

5 - REAR LIGHTS (CAB MODEL)

- A - Left rear indicator.
- B - Left tail light.
- C - Left rear stoplight.
- D - Right rear stoplight.
- E - Right tail light.
- F - Right rear indicator.



6 - REAR REVERSE LIGHT



7 - REVERSE BUZZER ALARM



8 - EMERGENCY STOP BUTTON

- In the event of danger, it lets you stop the I.C. Engine and thereby cut out all hydraulic movements.
- Turn the button to disable it before restarting the lift truck.

 **Be ready for hydraulic movements suddenly stopping when you press this button.**



9 - ADAPTATION CONTROLS LIFTING/TILTING REVERSED

LIFTING OF THE LOAD

- The lever A backwards when lifting.
- The lever A forwards when lowering.

NOTE : The engine r.p.m. automatically increases when lifting the load.

TILT OF THE MAST

- The lever A to the left for backward tilting.
- The lever A to the right for forward tilting.



10 - ADAPTATION 4TH SINGLE-ACTING OR DOUBLE-ACTING DISTRIBUTOR ELEMENT

ADDITIONAL ATTACHMENT

- The lever C forwards or backwards.



11 - ADAPTATION 3 ON LINE DISTRIBUTOR ELEMENTS

LIFTING OF THE LOAD

- The lever A backwards when lifting.
- The lever A forwards when lowering.

NOTE : The engine r.p.m. automatically increases when lifting the load.

TILT OF THE MAST

- The lever B backwards for backward tilting.
- The lever B forwards for forward tilting.

ATTACHMENT

- The lever C forwards or backwards.

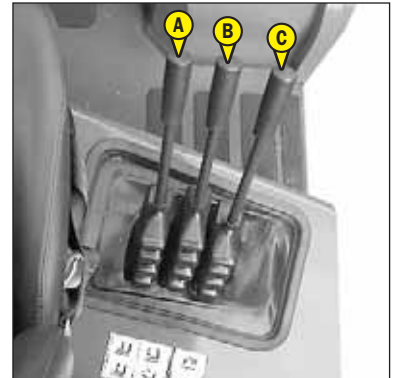

12 - ADAPTATION 4 ON LINE DISTRIBUTOR ELEMENTS

LIFTING OF THE LOAD

- The lever A backwards when lifting.
- The lever A forwards when lowering.

NOTE : The engine r.p.m. automatically increases when lifting the load.

TILT OF THE MAST

- The lever B backwards for backward tilting.
- The lever B forwards for forward tilting.

ATTACHMENT

- The lever C forwards or backwards.

ADDITIONAL ATTACHMENT

- The lever D forwards or backwards.

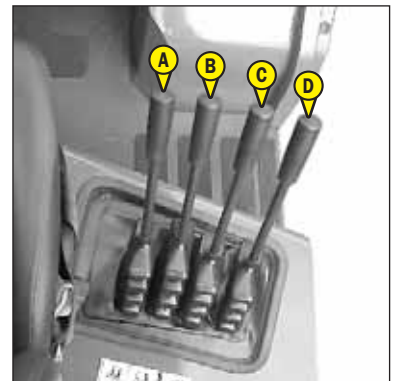

13 - ADAPTATION «INCHING» HYDRAULIC TRANSMISSION CUT-OFF

This pedal operates in two steps :

- First, the pedal acts upon a hydraulic valve which progressively cuts off the hydrostatic transmission so as to carry out a slow approach with all the I.C. engine output.
- Then, the pedal acts upon a hydraulic valve which progressively makes the pressure in the brakes drop so as to immobilize the lift truck.



14 - FOOT ADAPTATION GEAR REVERSER

The lift truck must be stationary when operating the forward/reverse lever.

FORWARD : Press the pedal 1 on the right.

REVERSE : Press the pedal 2 on the left.

NEUTRAL : To start the lift truck, do not press the reverser pedals.

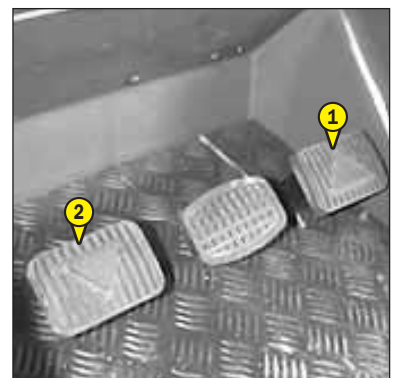

3 - MAINTENANCE

TABLE OF CONTENTS

MANITOU ORIGINAL SPARE PARTS AND EQUIPMENT	3-4
START-UP CHECKLIST	3-5
FILTERS CARTRIDGES AND BELTS	3-7
LUBRICANTS AND FUEL	3-8
SERVICING SCHEDULE	3-10
A - DAILY OR EVERY 10 HOURS SERVICE	3-12
B - EVERY 50 HOURS SERVICE	3-14
C - EVERY 250 HOURS SERVICE	3-18
D - EVERY 500 HOURS SERVICE	3-20
E - EVERY 1000 HOURS SERVICE	3-24
F - EVERY 2000 HOURS OF SERVICE	3-28
G - OCCASIONAL MAINTENANCE	3-30

MANITOU ORIGINAL SPARE PARTS AND EQUIPMENT

OUR LIFT TRUCKS MUST BE SERVICED USING ORIGINAL MANITOU PARTS.

IF YOU USE PARTS WHICH ARE NOT ORIGINAL MANITOU PARTS,

YOU RISK

- Legally - to be held responsible in the event of an accident.
- Technically - to generate operating failure or shorten the life of the lift truck.

**THE USE OF COUNTERFEIT PARTS OR COMPONENTS NOT APPROVED BY THE MANUFACTURER,
MEANS YOU LOSE THE BENEFIT OF THE CONTRACTUAL GUARANTEE.**

BY USING ORIGINAL MANITOU PARTS FOR MAINTENANCE OPERATIONS,

YOU BENEFIT EXPERTISE

- Through its network, MANITOU provides the user with
- Know-how and competence.
 - The guarantee of high-quality work.
 - Original replacement components.
 - Help with preventive maintenance.
 - Efficient help with diagnosis.
 - Improvements due to experience feedback.
 - Operator training.
 - Only the MANITOU network has detailed knowledge of the design of the lift truck and therefore the best technical ability to provide maintenance.

ORIGINAL REPLACEMENT PARTS ARE DISTRIBUTED EXCLUSIVELY BY MANITOU AND ITS DEALER NETWORK.
the dealer network list is available on manitou web site www.manitou.com

START-UP CHECKLIST







0 = OK 1 = Missing 2 = Incorrect

100 ENGINE	
01	Air filter
02	Fuel tank
03	Fuel lines - Filter
04	Injection or carburetion system
05	Radiator and cooling system
06	Belts
07	Hoses
101 TRANSMISSION	
01	Direction reversal system
02	Gear shift
03	Cut-off pedal
04	Clutch
102 AXLES/TRANSFER GEAR BOX	
01	operation and seal
02	Stop settings
103 HYDRAULIC/HYDROSTATIC CIRCUIT	
01	Tank
02	Pumps and couplings
03	Tightening of connections
04	Lift cylinder(s)
05	Tilt cylinder(s)
06	Attachment cylinder(s)
07	Telescope cylinder(s)
08	Compensation cylinder(s)
09	Steering cylinder(s)
10	Control Valve
11	Balancing valve
104 BRAKE SYSTEM	
01	Service brake and parking brake operation
02	Brake fluid level
105 LUBRICATION AND GREASING	
106 JIB/MANISCOPIC/MANIACCESS ASSEMBLY	
01	Beam and telescope(s)
02	Skid
03	Hinges
04	Carriage
05	Forks
107 MAST ASSEMBLY	
01	Fixed and mobile uprights
02	Carriage
03	Chains
04	Rollers
05	Forks

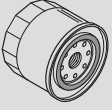
108 ATTACHMENTS	
01	Fitting on machine
02	Hydraulic couplings
109 CABIN/PROTECTOR/ELECTRIC CIRCUIT	
01	Seat
02	Dashboard and radio
03	Sound and visual alarm/safety system
04	Heating/Air conditioning
05	Windscreen wiper/windscreen washer
06	Road horn
07	Reversing horn
08	Road lights
09	Additional lights
10	Rotating beacon light
11	Battery
110 WHEEL	
01	Rims
02	Tyre/Pressure
111 SCREWS	
112 FRAME AND BODYWORK	
113 PAINTING	
114 GENERAL OPERATION	
115 OPERATOR'S MANUAL	
116 CUSTOMER INSTRUCTIONS	

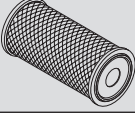
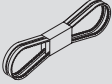
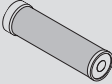

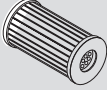
FILTERS CARTRIDGES AND BELTS

I.C. ENGINE

	I.C. ENGINE OIL FILTER Part number: 272192 Change: 500 H		FUEL TANK BREATHER Part number: 222381 Change: 1000 H
	DRY AIR FILTER CARTRIDGE Part number: 227959 Clean: 50 H* Change: 500 H*		ALTERNATOR BELT Part number: 747994 Change: 500 H
	SAFETY DRY AIR FILTER CARTRIDGE Part number: 227960 Change: 1000 H*		CYCLONIC PRE-FILTER (OPTION) Part number: 588330 Clean: 10 H
	FUEL FILTER CARTRIDGE Part number: 748087 Change: 500 H		AUTOMATIC VACUUM-CLEANING PRE-FILTER (OPTION) Part number: 240334
	FUEL PRE-FILTER Part number: 272194 Change: 500 H		

*: This periodicity is given for information only (see: 3 - MAINTENANCE: SERVICING SCHEDULE) for cleaning and changing.

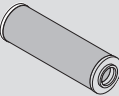
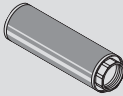
HYDRAULIC

	HYDRAULIC RETURN OIL FILTER CARTRIDGE Part number: 602096 Change: 500 H		SUCTION STRAINER FOR HYDRAULIC OIL TANK Part number: 77402 Clean: 1000 H
	FILTER CAP FOR HYDRAULIC OIL TANK Part number: 62415 Change: 1000 H		

LUBRICANTS AND FUEL



USE THE RECOMMENDED LUBRICANTS AND FUEL:

- For topping up, oils may not be miscible.
- For oil changes, MANITOU oils are perfectly appropriate.

DIAGNOSTIC ANALYSIS OF OILS

If a service or maintenance contract has been organized with the dealer, a diagnostic analysis of engine, transmission and axle oils may be requested depending on the rate of use.

(*) RECOMMENDED FUEL SPECIFICATION:

Use a high-quality fuel to obtain optimal performance of the I.C. engine.

- N590 diesel fuel type - Auto/C0/C1/C2/C3/C4
- BS2869 Class A2
- ASTM D975-91 Class 2-2DA, US DF1, US DF2, US DFA
- JIS K2204 (1992) Grades 1, 2, 3 and Special Grade 3

I.C. ENGINE				
ORGANS TO BE LUBRICATED	CAPACITY	RECOMMENDATION	PACKAGING	PART NUMBER
I.C. ENGINE	10 Liters	MANITOU Oil API CH4	5 l	661706
			20 l	582357
			55 l	582358
			209 l	582359
			1000 l	490205
COOLING CIRCUIT	10 Liters	Cooling liquid (protection - 30°)	2 l	473076
			5 l	470077
			20 l	470078
		Cooling liquid (protection - 25°)	2 l	554002
			5 l	554003
			20 l	554004
FUEL TANK	73,5 Liters	Diesel fuel (*)		

MAST				
ORGANS TO BE LUBRICATED		RECOMMENDATION	PACKAGING	PART NUMBER
MAST LIFTING CHAINS		MANITOU Lubricant Chain special (aerosol)	400 ml.	554271
GREASING OF THE MAST		MANITOU Grease BLACK multi-purpose	400 g.	545996
			1 kg.	161590
			50 kg.	499235

HYDRAULIC				
ORGANS TO BE LUBRICATED	CAPACITY	RECOMMENDATION	PACKAGING	PART NUMBER
HYDRAULIC OIL TANK	95 Liters	MANITOU Oil Hydraulic ISO VG 46	5 l	545500
			20 l	582297
			55 l	546108
			209 l	546109

REAR AXLE				
ORGANS TO BE LUBRICATED		RECOMMENDATION	PACKAGING	PART NUMBER
SWIVEL PINS / WHEEL MOTOR PIVOTS STEERING CONNECTING ROD REAR AXLE OSCILLATION		MANITOU Grease BLUE multi-purpose	400 g	161589
			1 kg	720683
			5 kg	554974
			20 kg	499233
			50 kg	489670

TRANSMISSION				
ORGANS TO BE LUBRICATED	CAPACITY	RECOMMENDATION	PACKAGING	PART NUMBER
FRONT WHEELS REDUCERS	1 Liter	MANITOU Oil SAE80W90 Mechanical transmission	5 l	499237
			20 l	546330
			55 l	546221
			209 l	546220

OVERHEAD GUARD

ORGANS TO BE LUBRICATED	RECOMMENDATION	PACKAGING	PART NUMBER
WINDSCREEN WASHER TANK	Windscreen washer fluid	1 L.	490402
		5 L.	486424

CAB (OPTION)

ORGANS TO BE LUBRICATED	RECOMMENDATION	PACKAGING	PART NUMBER
CAB DOOR	MANITOU Grease BLUE multi-purpose	400 g	161589
		1 kg	720683
		5 kg	554974
		20 kg	499233
		50 kg	489670
WINDSCREEN WASHER TANK	Windscreen washer fluid	1 L.	490402
		5 L.	486424

SERVICING SCHEDULE

(1): MANDATORY 500 HOUR OR 6 MONTH SERVICE

This service must be carried out after approximately the first 500 hours of operation or within the 6 months following the start-up of the machine (whichever occurs first).

A = ADJUST, C = CHECK, G = GREASE, N = CLEAN, P = BLEED, R = REPLACE, V = DRAIN	PAGE	 (1)	DAILY OR EVERY 10 HOURS SERVICE	EVERY 50 HOURS SERVICE	EVERY 250 HOURS SERVICE	EVERY 500 HOURS SERVICE OR 6 MONTHS	EVERY 1000 HOURS SERVICE OR 1 YEAR	EVERY 2000 HOURS SERVICE OR 2 YEARS	EVERY 4000 HOURS SERVICE	OCCASIONALLY
I.C. ENGINE										
I.C. engine oil level	3-12	C	C	<<<	<<<	<<<	<<<	<<<	<<<	
Cooling liquid level	3-12	C	C	<<<	<<<	<<<	<<<	<<<	<<<	
Fuel level	3-13	C	C	<<<	<<<	<<<	<<<	<<<	<<<	
Cyclonic pre-filter (OPTION)	3-13	N	N	<<<	<<<	<<<	<<<	<<<	<<<	
Dry air filter cartridge	3-14/21	R		N	<<<	R	<<<	<<<	<<<	
Radiator core	3-14	N		N	<<<	<<<	<<<	<<<	<<<	
Fuel filter	3-18	N			N	<<<	<<<	<<<	<<<	
Alternator/fan/crankshaft belt tension	3-18	A			C/A	<<<	<<<	<<<	<<<	
I.C. engine oil **	3-20	V				V	<<<	<<<	<<<	
I.C. engine oil filter **	3-20	R				R	<<<	<<<	<<<	
Fuel filter cartridge	3-21	R				R	<<<	<<<	<<<	
Fuel pre-filter	3-22	R				R	<<<	<<<	<<<	
Alternator/fan/crankshaft belt	3-22	R				R	<<<	<<<	<<<	
Fuel tank	3-24						N	<<<	<<<	
Fuel tank breather	3-24						R	<<<	<<<	
Safety dry air filter cartridge	3-24						R	<<<	<<<	
I.C. engine silent blocks							C*	<<<	<<<	
I.C. engine rates							C*	<<<	<<<	
Valves clearances		C*					C*	<<<	<<<	
Cooling liquid	3-28							V	<<<	
Injection pump								C*	<<<	
Injectors								C*	<<<	
Radiator								C*	<<<	
Water pump and the thermostat								C*	<<<	
Alternator and the starter motor								C*	<<<	
Turbocompressor								C*	<<<	
Fuel circuit	3-30									P
TRANSMISSION										
Front wheels reducers oil level	3-14	C		C	<<<	<<<	<<<	<<<	<<<	
Front wheels reducers oil	3-29	V						V	<<<	
Hydrostatic transmission circuit pressures								C*	<<<	
Governing start of the hydrostatic transmission								C*	<<<	
Working order of the hydraulic valves for the transmission cut-off and accelerator								C*	<<<	
Wearing of brake discs									C*	
TYRES										
Tyre pressure	3-13	C	C	<<<	<<<	<<<	<<<	<<<	<<<	
Wheel nut torque	3-13	C	C	<<<	<<<	<<<	<<<	<<<	<<<	
Condition of wheels and tyres							C*	<<<	<<<	
Wheel	3-31									R
MAST										
Tension and alignment of the mast lifting chains	3-15	C/A		C/A	<<<	<<<	<<<	<<<	<<<	
Mast	3-15	G		G	<<<	<<<	<<<	<<<	<<<	
Mast lifting chains	3-23	N/C/G				N/C/G	<<<	C*	<<<	
Condition of mast unit								C*	<<<	
Chain rollers								C*	<<<	
Mast guide rollers								C*	<<<	
Mast bearing rollers								C*	<<<	
Thickness of the mast wearing plates								C*	<<<	
HYDRAULIC										
Hydraulic oil level	3-16	C		C	<<<	<<<	<<<	<<<	<<<	
Hydraulic return oil filter cartridge	3-23	R				R	<<<	<<<	<<<	
Hydraulic oil	3-25						V	<<<	<<<	
Suction strainer for hydraulic oil tank	3-25						N	<<<	<<<	
Filter cap for hydraulic oil tank	3-25						R	<<<	<<<	
Speeds of hydraulic movements							C*	<<<	<<<	
Hydraulic pump tubular filter							N*	<<<	<<<	
Condition of hoses and flexible pipes							C*	<<<	<<<	
Condition of cylinders (leakage, shafts)							C*	<<<	<<<	
Hydraulic circuit pressures								C*	<<<	
Hydraulic circuit outputs								C*	<<<	
Hydraulic oil tank								N*	<<<	

A = ADJUST, C = CHECK, G = GREASE, N = CLEAN,
P = BLEED, R = REPLACE, V = DRAIN

	PAGE	 (1)	DAILY OR EVERY 10 HOURS SERVICE	EVERY 50 HOURS SERVICE	EVERY 250 HOURS SERVICE	EVERY 500 HOURS SERVICE OR 6 MONTHS	EVERY 1000 HOURS SERVICE OR 1 YEAR	EVERY 2000 HOURS SERVICE OR 2 YEARS	EVERY 4000 HOURS SERVICE	OCCASIONALLY
BRAKE										
Brake system pressure							C*	<<<	<<<	
Brake							A*	<<<	<<<	
Brake solenoid valve filter							N*	<<<	<<<	
OVERHEAD GUARD										
Windscreen washer liquid level	3-16	C		C	<<<	<<<	<<<	<<<	<<<	
Seat belt	3-26						C	<<<	<<<	
Condition of the rear view mirrors							C*	<<<	<<<	
Structure							C*	<<<	<<<	
Raising the overhead guard in the event of a breakdown	3-32									XXX
CAB (OPTION)										
Windscreen washer liquid level	3-16	C		C	<<<	<<<	<<<	<<<	<<<	
Cab door	3-16	G		G	<<<	<<<	<<<	<<<	<<<	
Seat belt	3-26						C	<<<	<<<	
Condition of the rear view mirrors							C*	<<<	<<<	
Structure							C*	<<<	<<<	
Lift the cab in case of failure	3-32									XXX
ELECTRICITY										
Condition of wiring harness and cables							C*	<<<	<<<	
Lights and signals (OPTION)							C*	<<<	<<<	
Warning indicators							C*	<<<	<<<	
Battery failure	3-33									R
Front headlights (OPTION)	3-33									A
REAR AXLE										
MSI 20 T Série 2-E3 - MSI 20 T BUGGIE Série 2-E3 MSI 25 T Série 2-E3 - MSI 25 T BUGGIE Série 2-E3 MSI 30 T Série 2-E3 - MSI 30 T BUGGIE Série 2-E3 MSI 35 T Série 2-E3 - MSI 35 T BUGGIE Série 2-E3										
Swivel pins	3-17	G		G	<<<	<<<	<<<	<<<	G/C*	
Steering connecting rod	3-17	G		G	<<<	<<<	<<<	<<<	<<<	
Rear axle oscillation	3-17	G		G				G/C*	<<<	
Steering								C*	<<<	
Rear axle									C**	
MH 20-4 T BUGGIE Série 2-E3 MH 25-4 T BUGGIE Série 2-E3										
Wheel motor pivots	3-17	G		G	<<<	<<<	<<<	<<<	G/C*	
Steering connecting rod	3-17	G		G	<<<	<<<	<<<	<<<	<<<	
Rear axle oscillation	3-17	G		G	<<<	<<<	<<<	G/C*	<<<	
Steering								C*	<<<	
Rear axle									C*	
CHASSIS										
Structure							C*	<<<	<<<	
Bearings and articulation rings								C*	<<<	
ATTACHMENTS										
Forks wear		C*					C*	<<<	<<<	<<<
Attachment carriage							C*	<<<	<<<	
Condition of attachments							C*	<<<	<<<	
LIFT TRUCK										
Tow the lift truck	3-34/35									XXX
Sling the lift truck	3-36									XXX
Transport the lift truck on a platform	3-37									XXX

(*): Consult your dealer.

(**): To be performed after the first 50 hours of operation and then every 500 hours..

A - DAILY OR EVERY 10 HOURS SERVICE

A1 - I.C. ENGINE OIL LEVEL

CHECK

Place the lift truck on level ground with the I.C. engine stopped, and let the oil drain into the sump.

- Lift up the overhead guard or the cab (see : 2 - DESCRIPTION : INSTRUMENTS AND CONTROLS).
- Remove the dipstick 1 (fig. A1/1).
- Clean the dipstick and check the level between the two MAXI and MINI notches.
- If necessary, add oil (see : 3 - MAINTENANCE : LUBRICANTS AND FUEL) by the filler port 2 (fig. A1/2).
- Check visually that there is no leakage or seepage of oil in the I.C. engine.

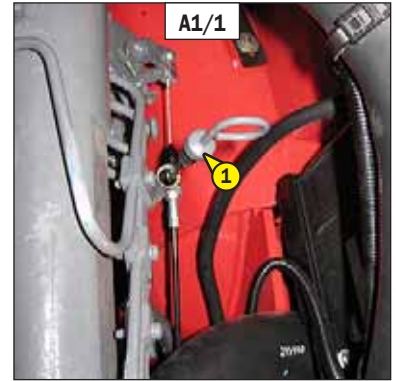

A2 - COOLING LIQUID LEVEL

CHECK

Place the lift truck on level ground with the I.C. engine stopped, and allow the I.C. engine to cool.

- Lift up the overhead guard or the cab (see : 2 - DESCRIPTION : INSTRUMENTS AND CONTROLS).
- The liquid must be at the MAXIMUM level on the expansion pan 1 (fig. A2/1).
- If necessary, add cooling liquid (see : 3 - MAINTENANCE : LUBRICANTS AND FUEL) through the filler port 2 (fig. A2/1).
- Check visually that there is no leakage in the radiator and pipes.

When the expansion pan is empty, check the level in the radiator before filling the expansion pan.

- Disassemble the cover plate 3 and the pre-filter 4 (fig. A2/2).
- Slowly bring the radiator cap 5 (fig. A2/3) up to the safety stop.
- Allow the pressure and the steam to escape.
- Press down and turn the cap so as to release it.
- Add cooling liquid through the filler port 6 (fig. A2/3) (see : 3 - MAINTENANCE : LUBRICANTS AND FUEL).
- Lubricate slightly the filler neck in order to facilitate the setting and the removal of the radiator cap.

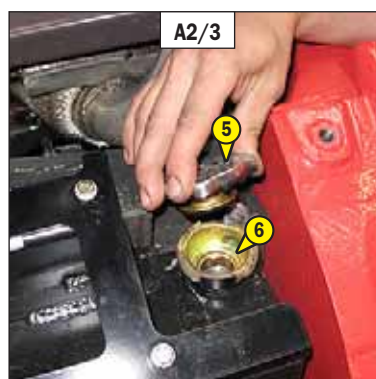
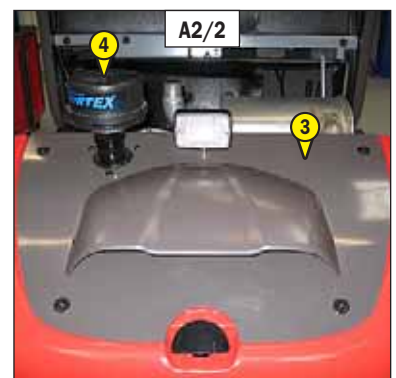
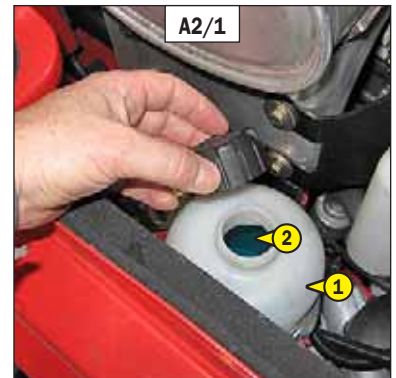

⚠ To avoid any risk of spraying or burning, wait until the I.C. engine has cooled down before removing the cooling circuit filler plug. If the cooling liquid is very hot, add only hot cooling liquid (80°C). In an emergency, you can use water as a cooling liquid, then change the cooling circuit liquid as soon as possible (see : 3 - MAINTENANCE : F1 - COOLING LIQUID).

A3 - FUEL LEVEL

CHECK

Keep the fuel tank full, to reduce as much as possible any condensation due to the atmospheric conditions.

- Remove cap 1 (fig. A3).
- Fill the fuel tank with clean fuel (see : 3 - MAINTENANCE : LUBRICANTS AND FUEL), filtered through a strainer or a clean, lint free cloth, through filler port 2 (fig. A3).
- Put the cap back 1 (fig. A3).
- Check visually that there is no leakage in the tank and pipes.

⚠ *Never smoke or approach with a flame during filling operations or when the tank is open. Never refill I.C. engine is running.*

⚠ *The fuel tank is degassed via the filler plug. When changing it, always use an original part, with degassing hole.*

NOTE : A locking tank cap is available as an OPTION.

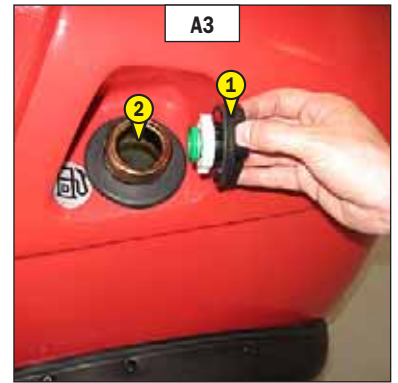

A4 - CYCLONIC PREFILTER (OPTION)

CLEAN

The cleaning interval is given as a guide, however the prefilter must be emptied as soon as impurities reach the MAXI level on the tank.

- Loosen nut 1 (fig. A4), remove cover 2 (fig. A4) and empty the tank.
- Clean the prefilter unit with a clean dry cloth and reassemble the unit.

⚠ *When cleaning, take care not to let impurities into the dry air filter.*

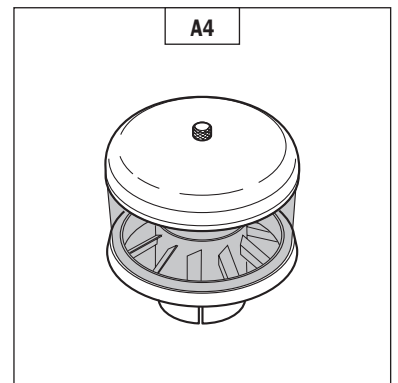

A5 - TYRES PRESSURE AND WHEEL NUTS TORQUE

CHECK

- Check the condition of the tyres, to detect cuts, protuberances, wear, etc.
- Check the torque load of the wheel nuts. Non compliance with this instruction can cause damage and rupture to the wheel bolts and distortion to the wheels.

Wheel nuts tightening torque

- Front tyres : 400 N.m \pm 15 %
 - Rear tyres : 200 N.m \pm 15 %
 - Rear tyres : 110 N.m \pm 15 %
- MSI 20 T Série 2-E3 - MSI 20 T BUGGIE Série 2-E3
MSI 25 T Série 2-E3 - MSI 25 T BUGGIE Série 2-E3
MSI 30 T Série 2-E3 - MSI 30 T BUGGIE Série 2-E3
MH 20-4 Turbo BUGGIE Série 2-E3
MH 25-4 Turbo BUGGIE Série 2-E3
MSI 35 Turbo Série 2-E3 - MSI 35 Turbo BUGGIE Série 2-E3

- Check and adjust the tyre pressures if necessary (see : 2 - DESCRIPTION : CHARACTERISTICS).

⚠ *Check that the air hose is correctly connected to the tyre valve before inflating and keep all persons at a distance during inflation. Respect the recommended tyre pressures given.*

B - EVERY 50 HOURS SERVICE

CARRY OUT THE OPERATIONS DESCRIBED PREVIOUSLY AS WELL AS THE FOLLOWING OPERATIONS.

B1 - DRY AIR FILTER CARTRIDGE

Check - Clean

In case of use in a heavily dust laden atmosphere, there are pre-filtration cartridges (see : 3 - MAINTENANCE : FILTERS CARTRIDGES AND BELTS). Also, the checking and cleaning periodicity of the cartridge must be reduced.

! *If the clogging indicator light comes on, this operation must be carried out as quickly as possible (1 hour maximum). The cartridge must not be cleaned more than seven times, after which the cartridge must be changed.*

- For the disassembly and reassembly of the cartridge, see : 3 - MAINTENANCE : D5 - DRY AIR FILTER CARTRIDGE.
- Clean the filter cartridge using a compressed air jet (max. pressure 3 bar) directed from the top to the bottom and from the inside towards the outside at a minimum distance of 30 mm from the cartridge wall.
- Cleaning is completed when there is no more dust on the cartridge.

! *Respect the safety distance of 30 mm between the air jet and the cartridge to avoid tearing or making a hole in the cartridge. The cartridge must not be blown anywhere near the air filter box. Never clean the cartridge by tapping it against a hard surface. Your eyes must be protected during this intervention.*

- Clean the cartridge seal surfaces with a damp, clean lint-free cloth and grease with a silicone lubricant (MANITOU reference : 479292).
- Check visually the outer condition of the air filter and its mounts. Verify the condition of the hoses and their mounts also.

! *Do not clean the dry air filter cartridge by washing it in liquid. Do not clean by any means the safety cartridge located inside the filter cartridge, change it for a new one if it is dirty or damaged.*

B2 - RADIATOR CORE

CLEAN

! *In a polluting atmosphere, clean the radiator core every day. Do not use a water jet or high-pressure steam as this could damage the radiator fins.*

- Lift up the overhead guard or the cab (see : 2 - DESCRIPTION : INSTRUMENTS AND CONTROLS).

In order to prevent the radiator becoming clogged, clean the radiator with a compressed air jet directed from outside to inside. This is the only way to clean the core of debris.

B3 - FRONT WHEELS REDUCERS OIL LEVEL

CHECK

Place the lift truck on level ground with the I.C. engine stopped.

- Check the oil level on each front wheel reducer.
- Place the level plugs 1 (fig. B3) into a horizontal position.
- Remove one of the level plugs, the oil must flush with the port.
- If necessary, add oil (see : 3 - MAINTENANCE : LUBRICANTS AND FUEL) through the same port.
- Replace the level plug 1 and tighten it (fig. B3) (tightening torque 60 to 70 N.m).

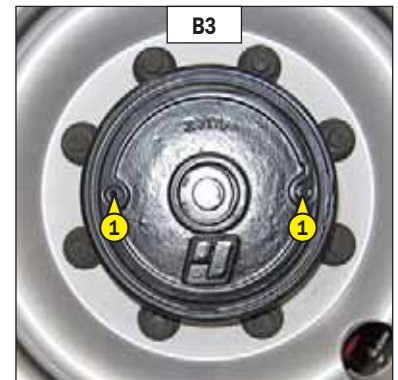

B4 - TENSION AND ALIGNMENT OF THE MAST LIFTING CHAINS

CHECK - ADJUST

Place the lift truck on level ground with the mast in a vertical position and the forks lifted at approximately 200 mm.

- Check the alignment of the mast lifting chains between the carriage's chain fasteners and the chain rollers.
- Manually verify the chain tension, if necessary adjust as following while ensuring that the carriage is perpendicular to the mast.
- Untighten the nut 1 (fig. B4).
- Untighten the lock nut 2 (fig. B4) of the chain tension adjuster.
- Adjust the tension by tightening or untightening the nut 3 (fig. B4) while checking the alignment of the lifting chains.
- Then block the lock nut 2 (fig. B4) and the nut 3 (fig. B4).
- Retighten the nut 1 (fig. B4).

⚠ *These checks are important for the good working operation of the mast. In case of technical faults, consult your dealer.*

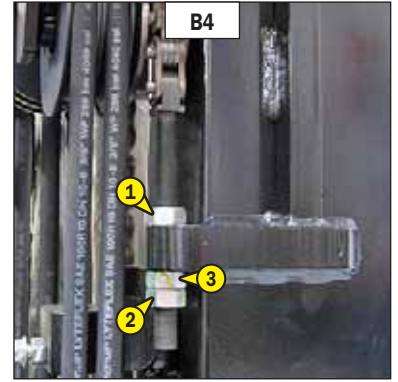

B5 - MAST

GREASE

To be carried out weekly, if the lift truck has been operated for less than 50 hours during the week.

⚠ *In the event of prolonged use in an extremely dusty or oxidising atmosphere, reduce this interval to 10 working hours or every day.*

Clean and lubricate the following points with grease (see : 3 - MAINTENANCE : LUBRICANTS AND FUEL) and remove the surplus of grease.

- 1 - Lubricators of the articulation axles at the foot of the mast (2 lubricators) (fig. B5/1).
- 2 - Lubricators of the tilt cylinders foot axles (2 lubricators) (fig. B5/2).
- 3 - Lubricators of the tilt cylinders head axles (2 lubricators) (fig. B5/3).

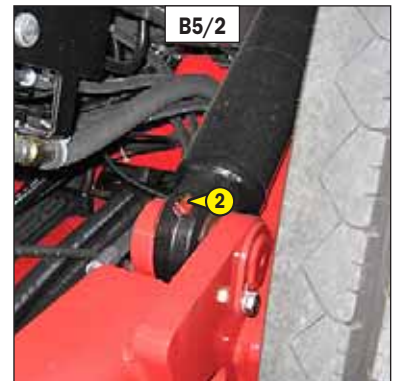
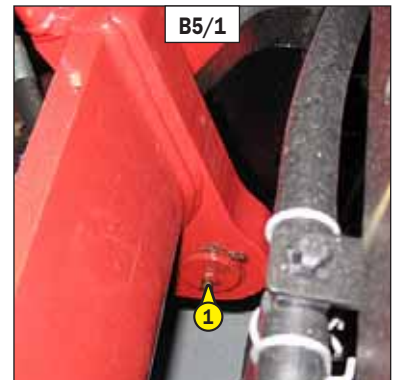

B6 - HYDRAULIC OIL LEVEL

CHECK

Place the lift truck on level ground with the I.C. engine stopped, the mast tilted backwards and lowered as far as possible.

- Refer to gauge 1 (fig. B6/1).
- The oil level is correct when it is at the level of the red point.
- If necessary, add oil (see : 3 - MAINTENANCE : LUBRICANTS AND FUEL).
- Lift up the overhead guard or the cab (see : 2 - DESCRIPTION : INSTRUMENTS AND CONTROLS).
- Remove cap 2 (fig. B6/2).
- Add oil by filler port 3 (fig. B6/2).

! Use a clean funnel and clean the underside of the oil drum before filling.

- Put the cap back.
- Check visually that there is no leakage in the tank and pipes.

Always maintain the oil level at maximum as cooling depends on the oil flowing through the tank.

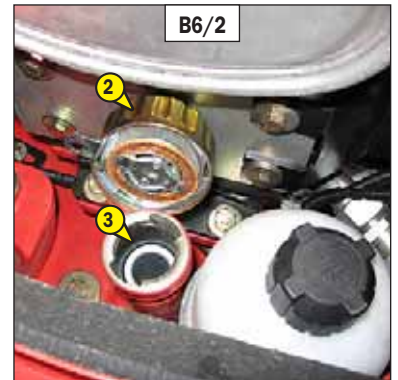
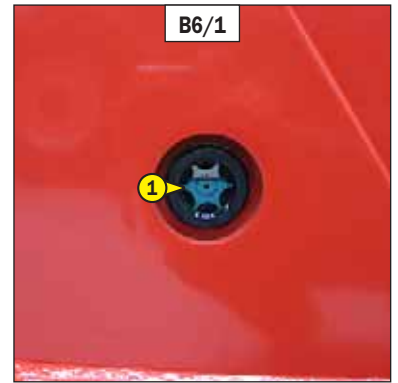

B7 - WINDSCREEN WASHER LIQUID LEVEL

CHECK

- Lift up the overhead guard or the cab (see : 2 - DESCRIPTION : INSTRUMENTS AND CONTROLS).
- Check visually the level.
- If necessary add windscreen washer liquid (see : 3 - MAINTENANCE : LUBRICANTS AND FUEL) by filler port 1 (fig. B7).

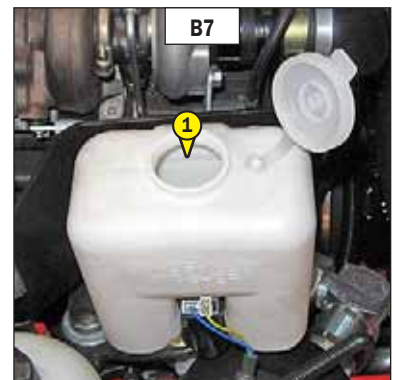

B8 - CAB DOOR (OPTION)

GREASE

- Clean and lubricate the points 1 (8 lubricators) (fig. B8) with grease (see : 3 - MAINTENANCE : LUBRICANTS AND FUEL) and remove the surplus of grease.

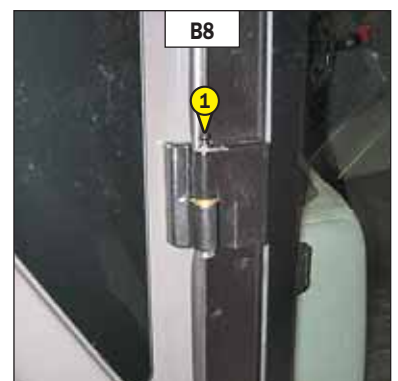

B9 - REAR AXLE

GREASE

MSI 20 T Série 2-E3 - MSI 20 T BUGGIE Série 2-E3
MSI 25 T Série 2-E3 - MSI 25 T BUGGIE Série 2-E3
MSI 30 T Série 2-E3 - MSI 30 T BUGGIE Série 2-E3
MSI 35 T Série 2-E3 - MSI 35 T BUGGIE Série 2-E3

- Clean and lubricate the following points with grease (see : 3 - MAINTENANCE : LUBRICANTS AND FUEL) and remove the surplus of grease.

- 1 - Lubricators of the swivel pins (6 lubricators) (fig. B9/1).
- 2 - Lubricators of the steering cylinder head axles (4 lubricators) (fig. B9/2).
- 3 - Lubricators of the rear axle oscillation pin (2 lubricators) (fig. B9/3).

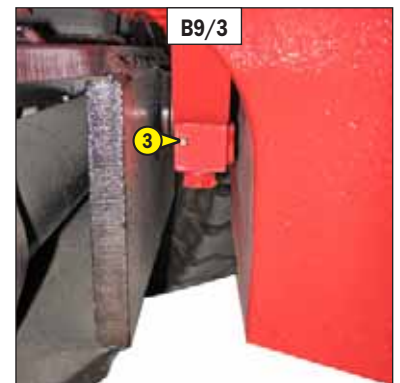
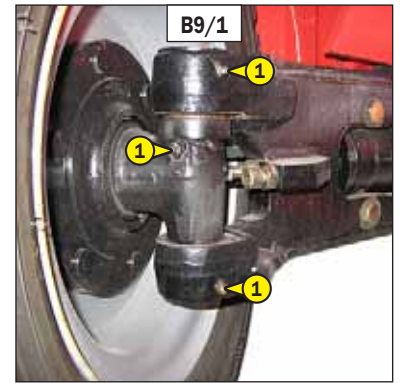

B9 - REAR AXLE

GREASE

MH 20-4 T BUGGIE Série 2-E3
MH 25-4 T BUGGIE Série 2-E3

- Clean and lubricate the following points with grease (see : 3 - MAINTENANCE : LUBRICANTS AND FUEL) and remove the surplus of grease.

- 1 - Lubricators of the swivel pins (4 lubricators) (fig. B9/1).
- 2 - Lubricators of the steering cylinder head axles (4 lubricators) (fig. B9/1).
- 3 - Lubricators of the rear axle oscillation pin (2 lubricators) (fig. B9/2).

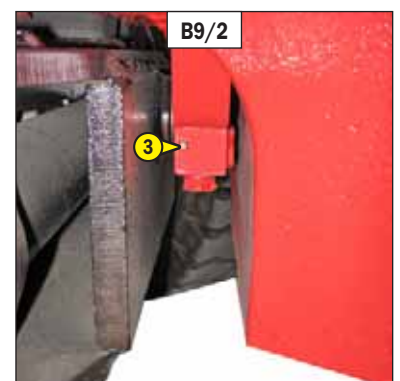
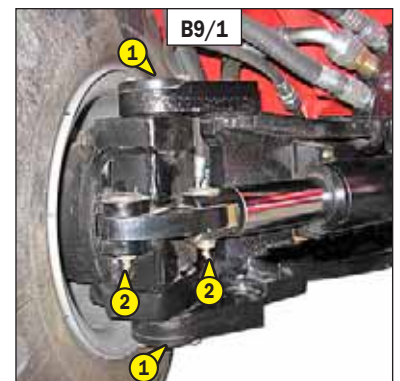

C - EVERY 250 HOURS SERVICE

Carry out the operations described previously as well as the following operations.

C1 - FUEL FILTER

CLEAN

- Lift up the overhead guard or the cab (see: 2 - DESCRIPTION: INSTRUMENTS AND CONTROLS).
- Close the fuel valve 1 (fig. C1/1) by setting to position B.
- Carefully clean the outside of the pre-filter and its holder, to prevent dust from getting into the system.
- Unscrew the retaining ring 2, remove the housing 3 (fig. C1/2) and clean the inside using a brush immersed in clean diesel oil.
- Remove the cartridge filter 4 (fig. C1/2) and dip in diesel oil to rinse.
- Reassemble the unit.
- Open the fuel valve 1 (fig. C1/1) by setting to position A.
- Bleed the fuel circuit (see: 3 - MAINTENANCE: G1 - FUEL SYSTEM).

! *Dust and impurities in the fuel will cause the injection pump and injectors to wear more quickly. To avoid this, regularly clean the fuel filter housing.*

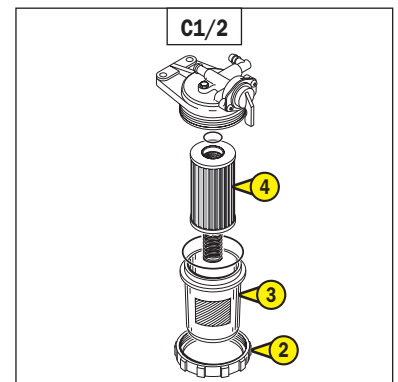
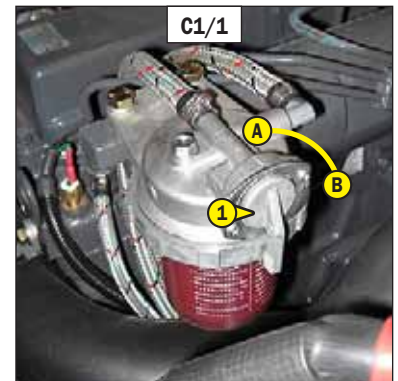

C2 - ALTERNATOR/FAN/CRANKSHAFT BELT TENSION

CHECK - ADJUST

- Lift up the overhead guard or the cab (see: 2 - DESCRIPTION: INSTRUMENTS AND CONTROLS).
- Check the belt for signs of wear and cracks and change if necessary (see: 3 - MAINTENANCE: FILTERS CARTRIDGES AND BELTS).
- Check the belt tension between the pulleys of the crankshaft and of the alternator.
- Under pressure applied by the thumb (98 N), the tension should be between 7 and 9 mm (fig. C2/1).
- Carry out adjustments if necessary.
- Untighten screws 1 (fig. C2/2) by two to three thread turns.
- Swivel the alternator assembly so as to obtain the belt tension required.
- Retighten screws 1 (fig. C2/2).

! *If the alternator belt has to be changed, check the tension again after the first 20 hours of operation.*

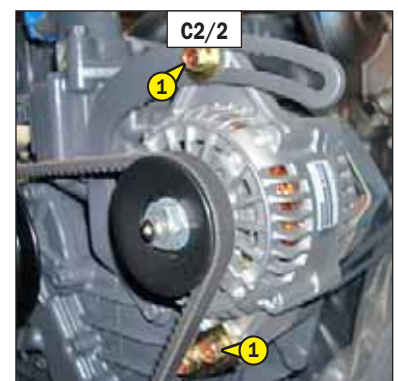
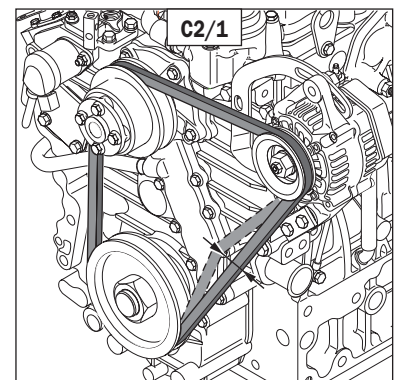

D - EVERY 500 HOURS SERVICE

Carry out the operations described previously as well as the following operations.

D1 - I.C. ENGINE OIL

DRAIN

D2 - I.C. ENGINE OIL FILTER

CHANGE

Place the lift truck on level ground, let the I.C. engine run at idle for a few minutes, then stop the I.C. engine.

DRAINING THE OIL

- Lift up the overhead guard or the cab (see: 2 - DESCRIPTION: INSTRUMENTS AND CONTROLS).
- Place a container under drain plug 1 (fig. D1/1) and unscrew the drain plug.
- Remove filling plug 2 (fig. D1/2) to ensure that the oil is drained properly.

 **Dispose of the drain oil in an ecological manner.**

REPLACEMENT OF THE FILTER

- Remove I.C. engine oil filter 3 (fig. D1/3) and discard the filter and the filter seal.
- Clean the filter bracket with a clean, lint-free cloth.
- Fill the new engine oil filter (see: 3 - MAINTENANCE: FILTERS CARTRIDGES AND BELTS) and lightly grease the seal.
- Fit the oil filter onto its holder.
- Tighten the oil filter by hand pressure only and lock the filter in place by a quarter turn.

FILLING UP THE OIL

- Refit and tighten drain plug 1 (fig. D1/1) (tightening torque 30 to 40 N.m).
- Fill up with oil (see: 3 - MAINTENANCE: LUBRICANTS AND FUEL) by filler port 4 (fig. D1/2).

NOTE: For this operation, we recommend you use a funnel fitted with a hose.

- Wait a few minutes to allow the oil to flow into the sump.
- Start the I.C. engine and let it run for a few minutes.
- Check for possible leaks at the drain plug and the oil filter.
- Stop the I.C. engine, wait a few minutes and check the level against the upper mark on dipstick 5 (fig. D1/4).
- Top up the level if necessary.

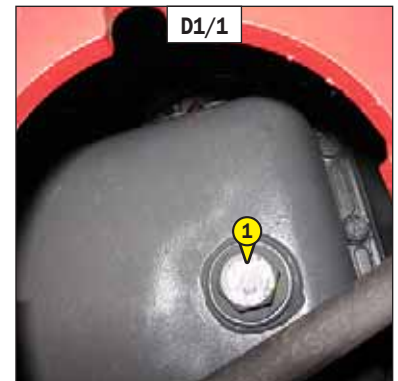

D3 - DRY AIR FILTER CARTRIDGE

CHANGE

In case of use in a heavily dust laden atmosphere, there are pre-filtration cartridges, see: 3 - MAINTENANCE: FILTERS CARTRIDGES AND BELTS. Also, the checking and cleaning periodicity of the cartridge must be reduced (up to 250 hours in a heavily laden dust atmosphere and with pre-filtration).

⚠ Change the cartridge in a clean location, with the I.C. engine stopped. Never operate the lift truck with the air filter removed or damaged.

- Lift up the overhead guard or the cab (see: 2 - DESCRIPTION: INSTRUMENTS AND CONTROLS).
- Loosen the bolts and remove cover 1 (fig. D3).
- Gently remove the cartridge 2 (fig. D3), taking care to avoid spilling the dust.
- Leave the safety cartridge in place.
- The following parts must be cleaned with a damp, clean lint-free cloth.
 - The inside of the filter and cover.
 - The inside of the filter inlet hose.
 - The gasket surfaces in the filter and in the cover.
- Check pipes and connections between the air filter and the I.C. engine and the connection and state of the clogging indicator on the filter.
- Before mounting check the state of the new cartridge (see: 3 - MAINTENANCE: FILTERS CARTRIDGES AND BELTS).
- Introduce the cartridge into the filter axis and push it in, pressing the edges and not the middle.
- Reassemble the cover, guiding the valve downwards.

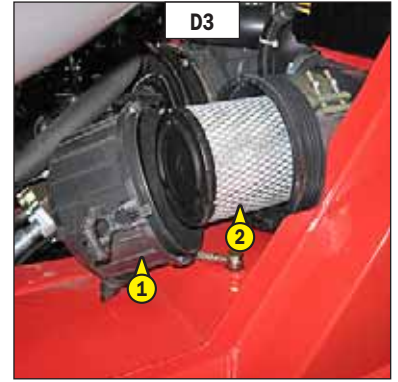

D4 - FUEL FILTER CARTRIDGE

CHANGE

- Lift up the overhead guard or the cab (see: 2 - DESCRIPTION: INSTRUMENTS AND CONTROLS).
- Carefully clean the outside of the filter and its holder, to prevent dust from getting into the system.
- Close the fuel valve 1 (fig. D4/1) by setting to position B.
- Unscrew the retaining ring 2, remove the housing 3 (fig. D4/2) and clean the inside using a brush immersed in clean diesel oil.
- Discard the filter cartridge 4 (fig. D4/2).
- Refit the assembly with a new cartridge (see: 3 - MAINTENANCE: FILTERS CARTRIDGES AND BELTS).

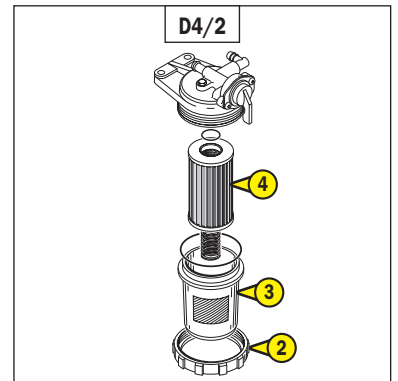
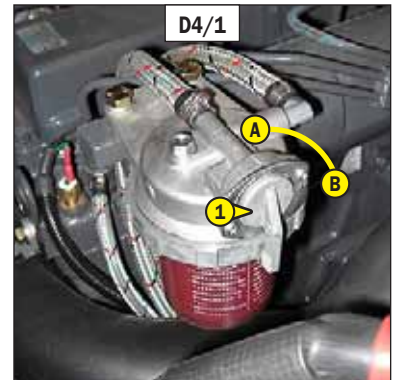

D5 - FUEL PRE-FILTER

CHANGE

- Take the pre-filter 1 from the clip 2 (fig. D5/1).
- Remove and discard the pre-filter 1 (fig. D5/2).
- Fit a new pre-filter (see: 3 - MAINTENANCE: FILTERS CARTRIDGES AND BELTS).
- Place the new pre-filter under the clip 2 (fig. D5/1).
- Open the fuel valve 1 (fig. D4/1) by setting to position A.

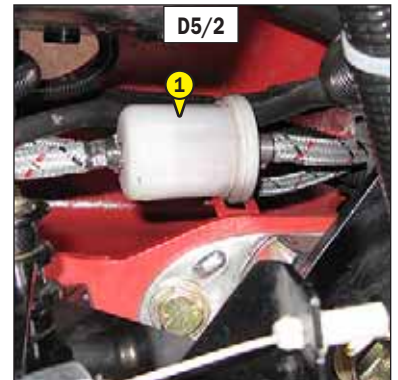
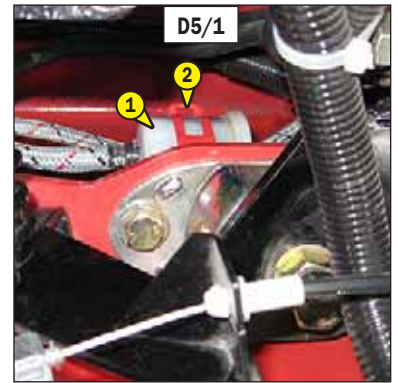

D6 - ALTERNATOR/FAN/CRANKSHAFT BELT

CHANGE

- Lift up the overhead guard or the cab (see: 2 - DESCRIPTION: INSTRUMENTS AND CONTROLS).
- Untighten screws 1 (fig. D6) by two to three thread turns.
- Swivel the alternator assembly so as to pay up the belt 2 (fig. D6) and replace with a new one (see: 3 - MAINTENANCE: FILTERS CARTRIDGES AND BELTS).
- Adjust the belt tension between the crankshaft and alternator pulleys.
- Under pressure applied by the thumb (98 N), the tension should be between 7 et 9 mm.
- Re-tighten the screws 1 (fig. D6).

⚠ *If the alternator belt has to be changed, check the tension again after the first 20 hours of operation.*

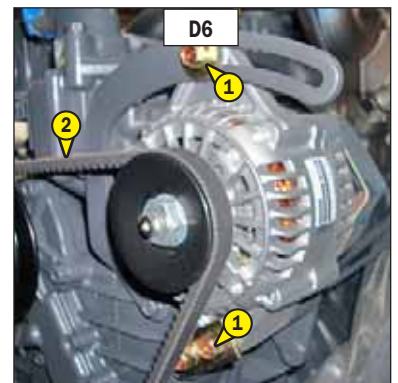

D7 - MAST LIFTING CHAINS

CLEAN - CHECK - GREASE

- Wipe the mast lifting chains 1 (fig. D7) with a clean, lint-free cloth, then examine them closely so as to detect any signs of wear.
- Vigorously brush the chains to get rid of any foreign matter, with a hard nylon brush and clean diesel fuel.
- Rinse the chains by means of a paint brush impregnated with clean diesel fuel and dry them with a compressed air jet.
- Moderately lubricate the chains (see: 3 - MAINTENANCE: LUBRICANTS AND FUEL).

 **In case of technical faults, consult your dealer.**

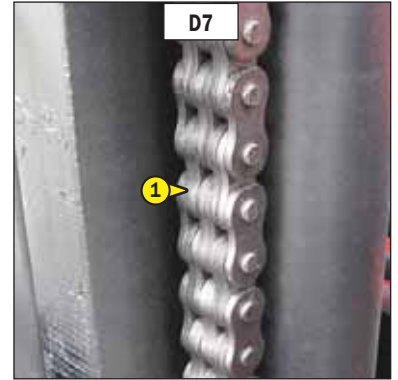

D8 - HYDRAULIC RETURN OIL FILTER CARTRIDGE

CHANGE

Stop the I.C. engine and remove the pressure from the circuits by acting on the hydraulic controls.

 **Thoroughly clean the outside of the filter and its surroundings before any intervention in order to prevent any risk of polluting the hydraulic circuit.**

- Lift up the overhead guard or the cab (see: 2 - DESCRIPTION: INSTRUMENTS AND CONTROLS).
- Remove the plug 1 (fig. D8/1).
- Move the windscreen washer fluid tank to one side and unscrew the cap 2 (fig. D8/2) two to three turns.
- Wait a few moments while the oil flows into the tank.
- Remove the cover and take out filter cartridge assembly 3 (fig. D8/3).
- Place the assembly in a clean container and empty the bowl.
- Remove the bowl 4 and the top 5 of the filter cartridge 6 (fig. D8/4) by a movement of rotation.
- Refit the bowl and the top onto a new cartridge (see: 3 - MAINTENANCE: FILTER ELEMENTS AND BELTS).
- Fit the assembly in place and retighten the cover 2 (fig D8/2).
- Put the cap back 1 (fig. D8/1).

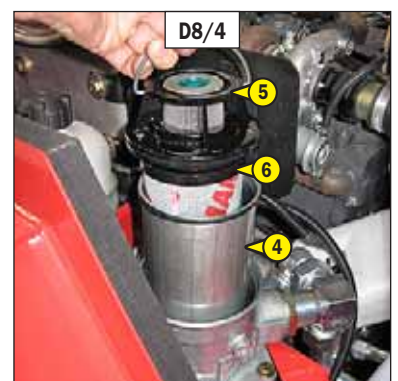
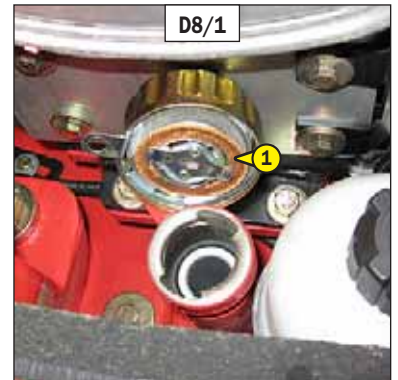

E - EVERY 1000 HOURS SERVICE

Carry out the operations described previously as well as the following operations.

E1 - FUEL TANK

CLEAN

E2 - FUEL TANK BREATHER

CHANGE

! While carrying out these operations, do not smoke or work near a flame.

Place the lift truck on level ground with the I.C. engine stopped.

- Inspect the parts susceptible to leaks in the fuel circuit and in the tank.
- In the event of a leak, contact your dealer.

! Never try to carry out a weld or any other operation by yourself, this could provoke an explosion or a fire.

- Place a container under drain plug 1 (fig. E1/1) and unscrew the plug.
- Remove filling plug 2 (fig. E1/2) in order to ensure that the oil is drained properly.
- Rinse out with ten liters of clean diesel through filler port 3 (fig. E1/2).
- Refit and tighten the drain plug (tightening torque 29 to 39 N.m).
- Fill the fuel tank with clean diesel filtered through the filler port.
- Refit the filling cap.
- Remove the breather 4 from the underside of the counterweight 5 (fig. E1/3).
- Dismantle the breather and replace with a new one (see: 3 - MAINTENANCE: FILTERS CARTRIDGES AND BELTS).
- Position the new breather beneath the counterweight 5 (fig. E1/3).
- If necessary, bleed the fuel circuit (see: 3 - MAINTENANCE: G1 - FUEL SYSTEM).

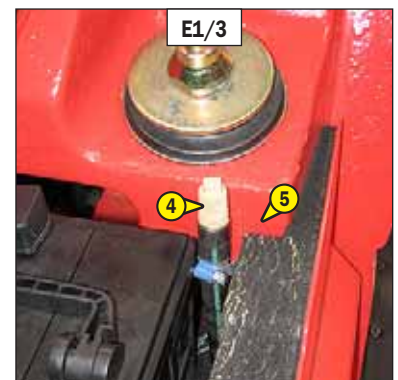
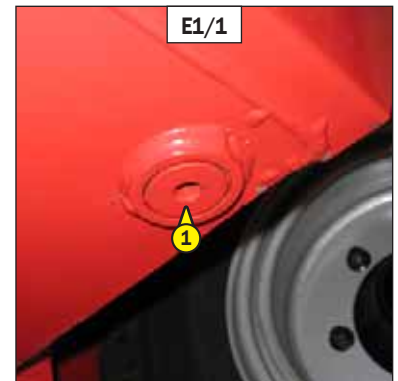

E3 - SAFETY DRY AIR FILTER CARTRIDGE

CHANGE

- For the disassembly and reassembly of the dry air filter cartridge, see: 3 - MAINTENANCE: D3 - AIR FILTER CARTRIDGE.
- Gently remove the dry air filter safety cartridge 1 (fig. E3), taking care to avoid spilling the dust.
- Clean the gasket surface on the filter with a damp, clean lint-free cloth.
- Before mounting, check the state of the new safety cartridge (see: 3 - MAINTENANCE: FILTERS AND BELTS).
- Introduce the cartridge into the filter axis and push it in, pressing the edges and not the middle.

NOTE: The periodicity for changing the safety cartridge is given for information only. It must be changed for every two changes of the dry air filter cartridge.

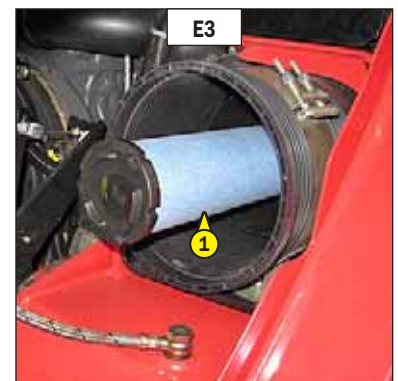

E4 - HYDRAULIC OIL

DRAIN

E5 - SUCTION STRAINER FOR HYDRAULIC OIL TANK

CLEAN

E6 - FILTER CAP FOR HYDRAULIC OIL TANK

CHANGE

Put the lift truck on level ground, the I.C. engine stopped and the mast lowered as far as possible.

⚠ Before any intervention, thoroughly clean the area surrounding the drain plug and the suction cover on the hydraulic tank.

DRAINING THE OIL

- Lift up the overhead guard or the cab (see : 2 - DESCRIPTION : INSTRUMENTS AND CONTROLS).
- Place a container under drain plug 1 (fig. E4/1) and unscrew the plug.
- Remove filler cap 2 (fig. E4/2) in order to ensure that the oil is drained properly and get rid of it.

⚠ Dispose the drain oil in an ecological manner.

CLEANING THE STRAINER

- Disconnect the clogging indicator 3 (fig. E4/3).
- Disconnect the hoses 4 (fig. E4/3) at the level of the hydraulic return oil filter 5 (fig. E4/3).
- Unscrew the four screws 6 (fig. E4/3) and remove the complete filter 5 (fig. E4/3).
- Unscrew the suction strainer at the bottom of the tank, clean it with the help of a compressed air jet, check its condition and change it, if necessary (see : 3 - MAINTENANCE : FILTERS CARTRIDGES AND BELTS).
- Reassemble the strainer, the filter and re-connect the hoses and the clogging indicator.

FILLING UP THE OIL

- Clean and refit drain plug 1 (fig. E4/1) (tightening torque 29 to 39 N.m).
- Fill up with oil (see : 3 - MAINTENANCE : LUBRICANTS AND FUEL) by filler port 7 (fig. E4/2).

⚠ Use a clean container and funnel and clean the underside of the oil drum before filling.

- Observe the oil level on dipstick 8 (fig. E4/4) ; the oil level should be at the level of the red point.
- Check for any possible leaks at the drain plug.
- Replace filler plug 2 (fig. E4/2) with a new filler plug (see : 3 - MAINTENANCE : FILTERS CARTRIDGES AND BELTS).

POLLUTION ABATEMENT OF THE HYDRAULIC CIRCUIT

- Let the I.C. engine run (accelerator pedal at halfway travel) for 5 minutes without using anything on the lift truck, then for 5 more minutes while using completely the hydraulic movements (except the steering system).
- Accelerate the engine at full speed for 1 minute, then activate the steering system.
- This operation makes a pollution abatement of the circuit possible through the hydraulic return oil filter.

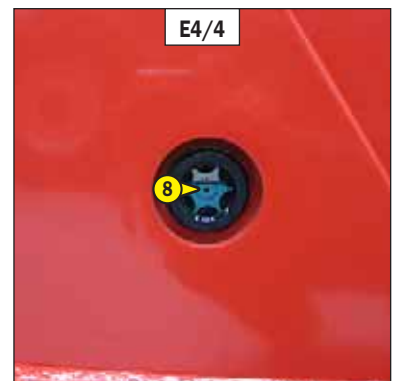
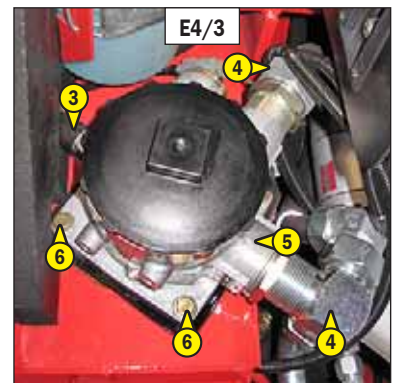
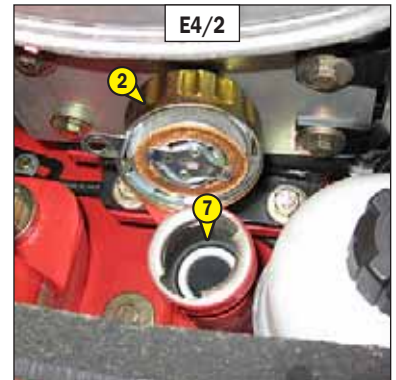

SEAT BELT WITH TWO ANCHORING POINTS

- Check the following points :

- Fixing of the anchoring points on the seat.
- Cleanness of the strap and the locking mechanism.
- Triggering of the locking mechanism.
- Condition of the strap (cuts, curled edges).

REELED SEAT BELT WITH TWO ANCHORING POINTS

- Check the points listed above together with the following points :

- The correct winding of the belt.
- Condition of the reel guards.
- Roller locking mechanism when the strap is given a sharp tug.

NOTE : After an accident, replace the seat belt.



Under no circumstances should you use the lift truck if the seat belt is faulty (fixing, locking, it has cuts or tears, etc). Repair or replace the seat belt immediately.

F - EVERY 2000 HOURS OF SERVICE

Carry out the operations described previously as well as the following operations.

F1 - COOLING LIQUID

DRAIN

These operations are to be carried out if necessary or every two years at the beginning of winter. Place the lift truck on level ground with the I.C. engine stopped and cold.

DRAINING THE LIQUID

- Lift up the overhead guard or the cab (see: 2 - DESCRIPTION: INSTRUMENTS AND CONTROLS).
- Disassemble the lower hose 1 (fig. F1/1) of the radiator.
- Unscrew the filler plug 2 (fig. F1/2) of the expansion tank and empty the latter.
- Remove the pre-filter 3 and the cover plate 4 (fig. F1/3).
- Remove filling plug 5 (fig. F1/4) of the radiator.
- Let the cooling circuit drain entirely while ensuring that the ports do not get clogged.
- Check the condition of the hoses as well as the fastening devices and change the hoses if necessary.
- Rinse the circuit with clean water and use a cleaning agent if necessary.

FILLING THE LIQUID

- Reassemble the lower hose 1 (fig. F1/1).
- Slowly fill the circuit with the cooling liquid (see: 3 - MAINTENANCE: LUBRICANTS AND FUEL) through the filler port 6 (fig. F1/4).
- Fill the expansion tank to the maximum level.
- Run the I.C. engine at idle for a few minutes.
- Check for any possible leaks.
- Check the level and refill if necessary.
- Put back filling plug 5 (fig. F1/4).
- Reassemble the cover plate 4 and the pre-filter 3 (fig. F1/3).
- Retighten filler cap 2 (fig. F1/2).

⚠ The I.C. engine does not contain any corrosion resistor and must be filled during the whole year with a mixture containing 25% of ethylene glycol-based antifreeze.

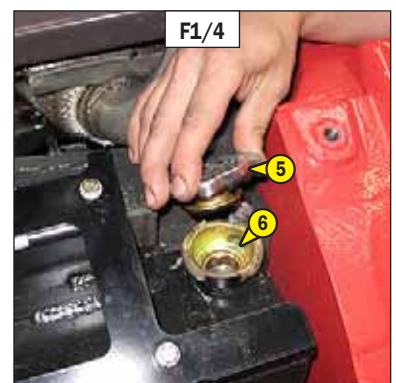
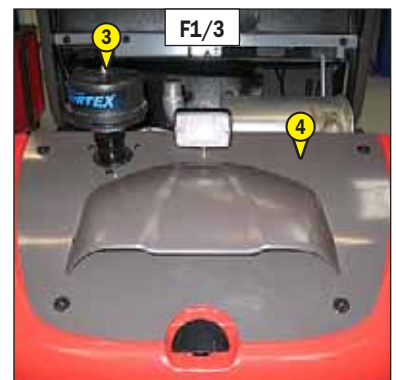
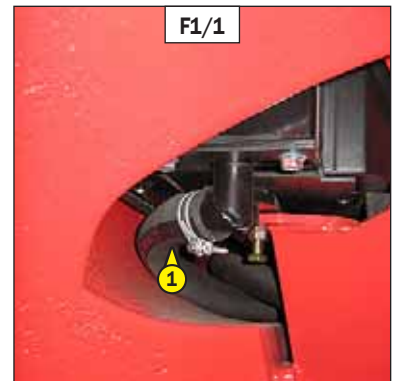

F2 - FRONT WHEELS REDUCERS OIL

DRAIN

This operation should be carried out once a year if the lift truck has not reached 2000 hours service within the year.

Place the lift truck on level ground with the I.C. engine stopped and the reducers oil still warm.

! *Dispose the drain oil in an ecological manner.*

- Drain and change each front wheel reducer.
- Place drain plug 1 (fig. F2) in position A.
- Place a container under the drain plug and unscrew the plug.
- Let the oil drain fully.
- Place the drain port in position B, i.e. in a level port.
- Fill up with oil (see : 3 - MAINTENANCE : LUBRICANTS AND FUEL) by level port 1 (fig. F2).
- The level is correct when the oil level is flush with the edge of the hole.
- Refit and tighten the drain plug 1 (fig. F2) (tightening torque 60 to 70 N.m).

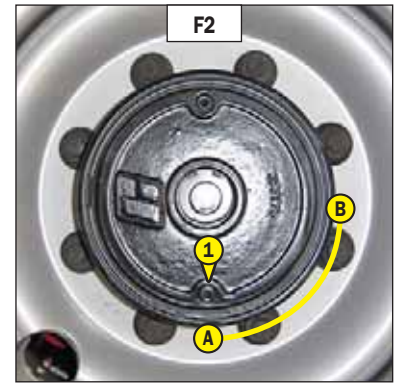

G - OCCASIONAL MAINTENANCE

G1 - FUEL SYSTEM

BLEED

These operations are to be carried out only in the following cases:

- A component of the fuel system replaced or drained.
- A drained tank.
- Running out of fuel.

Ensure that the level of fuel in the tank is sufficient and bleed in the following order:

- Lift up the overhead guard or the cab (see: 2 - DESCRIPTION: INSTRUMENTS AND CONTROLS).

BLEEDING THE FUEL FILTER

- Loosen bleed screw 1 (fig. G1/1).
- Switch on the lift truck ignition until the diesel oil flows from the bleeder screw free of any air.
- Tighten the bleed screw while the diesel fuel is flowing out.

BLEEDING THE INJECTION PUMP

- Open the bleed valve 2 (fig. G1/2).
- Switch on the lift truck ignition until the diesel oil flows from the bleeder screw free of any air.
- Seal the bleed valve while the diesel oil is flowing.

The I.C. engine is then ready to be started up.

NOTE: If the I.C. engine functions correctly for a short time then stops or functions irregularly, check for possible leaks in the low pressure circuit. If in doubt, contact your dealer.

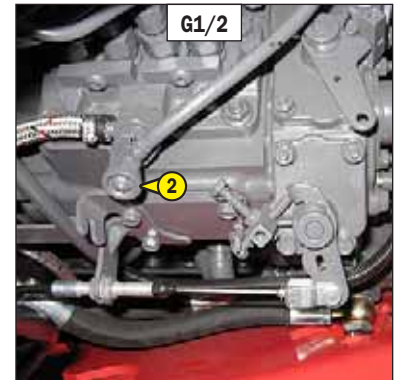
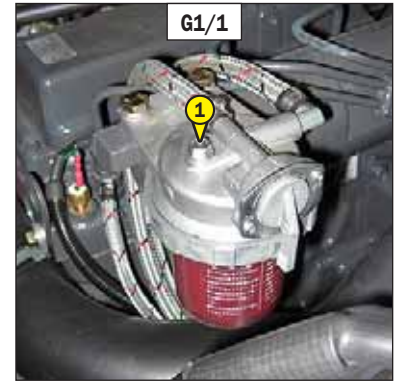

! *In the event of a wheel being changed on the public highway, make sure of the following points :*

- Stop the lift truck, if possible on even and hard ground.
- To pass on stop of lift truck (see : 1 - OPERATING AND SAFETY INSTRUCTIONS : DRIVING INSTRUCTIONS UNLADEN AND LADEN).
- Put the warning lights on (option).
- Immobilise the lift truck in both directions on the axle opposite to the wheel to be changed.
- Unlock the nuts of the wheel to be changed.

REAR WHEEL

For this operation, we advise you to use the hydraulic jack MANITOU Reference 505507.

- Place the jack under the counterweight. It must be situated in the middle and under the flat part of the counterweight (fig. G2/1).
- Lift the wheel until it lifts off the ground and fit security wedges under the rear axle (fig. G2/2).
- Completely unscrew the wheel nuts and remove them.
- Free the wheel by reciprocating movements and roll it to the side.
- Slip the new wheel on the wheel hub.
- Refit the nuts by hand, if necessary grease them.
- Remove the security wedges and lower the lift truck with the jack.
- Tighten the wheel nuts with a torque wrench (see : 3 - MAINTENANCE : A - DAILY OR EVERY 10 HOURS SERVICE for tightening torque).

FRONT WHEEL

- Lift the carriage and tilt the mast backwards.
- Put wedges under the foot of the mast on the side of the wheel to be changed (fig. G2/3).
- Tilt the mast forwards so as to lift the wheel.
- Place wedges under the chassis as near as possible to the wheel (fig. G2/4).
- Completely untighten the wheel nuts and remove them.
- Release the wheels by reciprocating movements and roll it on the side.
- Slide the new wheel onto the hub.
- Manually screw the nuts, if necessary lubricate them.
- Remove the wedges under the axle and lower the lift truck.
- Tighten the wheel nuts with a torque wrench (see : 3 - MAINTENANCE : A - DAILY OR EVERY 10 HOURS SERVICE for tightening torque).

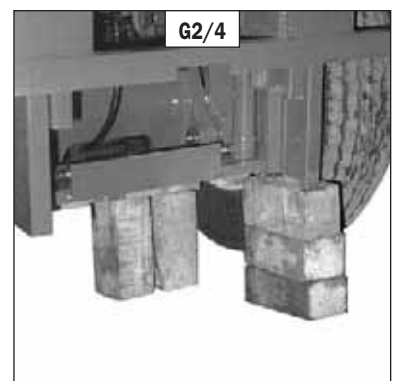
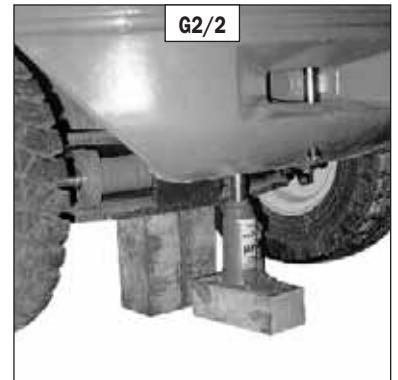

G3 - RAISING THE OVERHEAD GUARD OR THE CAB IN THE EVENT OF A BREAKDOWN

PROCEDURE IN THE EVENT OF HYDRAULIC FAILURE ON THE LIFTING SYSTEM

UNLOCKING THE OVERHEAD GUARD OR THE CAB:

- Unlock the overhead guard by means of the lever 1 (fig. A) in position A.
- With the cab model, close the doors.

RAISING THE OVERHEAD GUARD OR THE CAB:

⚠ Check that there is nothing laying on the driver's seat, which could disrupt the operation.

- If necessary, raise the mast until it is approximately 50 cm above the overhead guard or the cab.
- Unscrew the two screws 2 (fig. G3/2) on the roof and replace them with two MANITOU eyes 3 (fig. G3/3) Reference 72422.
- Pass a sling 4 around the mobile upright's upper belt and fasten the ends of the sling onto the eyes 3 (fig. G3/3).
- Switch on the engine.
- Gently raise the mast to tension the sling and raise the overhead guard or the cab a few centimetres.
- Return the lever 1 (fig. G3/1) to its initial position (position B).
- Tilt the mast forwards and raise it slowly until you can insert the safety stay 5 (fig. G3/4)
- Lower the mast to release and remove the sling.

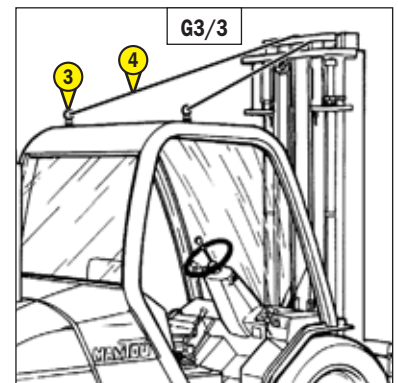
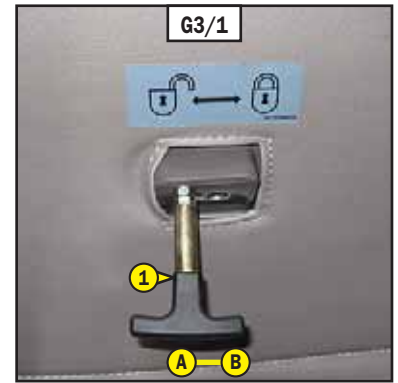

G4 - BREAKDOWN OF BATTERY

- Remove the exhaust pipe 1 (fig. G4/1).
- Remove the cowl 2 (fig. G4/1) to access the battery 3 (fig. G4/2).
- Bring a floating battery of the same type as the one used for the lift truck and battery cables.
- Connect the floating battery while respecting the polarity.
- Then, carry out the lifting of the overhead guard or cab (see: 2 - DESCRIPTION: INSTRUMENTS AND CONTROLS).
- Change a battery.

⚠ Handling and servicing a battery can be dangerous, take the following precautions:

- Wear protective goggles.
- Keep the battery horizontal.
- Never smoke or work near a naked flame.
- Work in a well-ventilated area.
- In the event of electrolyte being spilled onto the skin or splashed in the eyes, rinse thoroughly with cold water for 15 minutes and call a doctor.

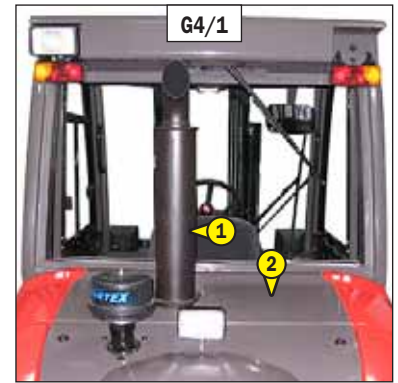

G5 - FRONT HEADLAMPS (OPTION)

ADJUST

RECOMMENDED SETTING

(as per standard ECE-76/756 76/761 ECE20)

Set to - 2% of the dipped beam in relation to the horizontal line of the headlamp.

ADJUSTING PROCEDURE

- Place the lift truck unloaded and in the transport position and perpendicular to a white wall on flat, level ground (fig. G5).
- Check the tyre pressures (see: 2 - DESCRIPTION: CHARACTERISTICS).
- Put the gear reverser lever in neutral and release the parking brake.

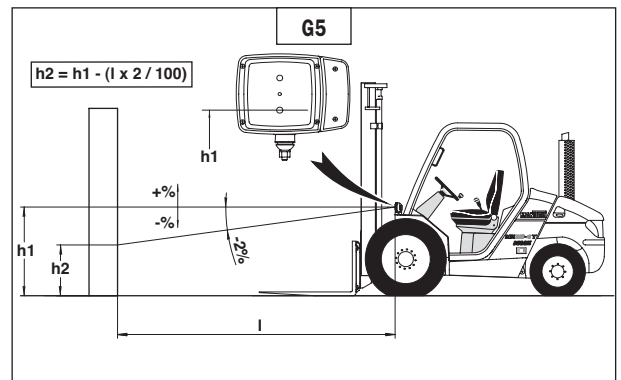

CALCULATING THE HEIGHT OF THE DIPPED BEAM (H2)

- h1 = Height of the dipped beam in relation to the ground.
- h2 = Height of the adjusted beam.
- l = Distance between the dipped beam and the white wall.

MSI 20 T Série 2-E3	MSI 20 T BUGGIE Série 2-E3
MSI 25 T Série 2-E3	MSI 25 T BUGGIE Série 2-E3
MSI 30 T Série 2-E3	MSI 30 T BUGGIE Série 2-E3
MSI 35 T Série 2-E3	MSI 35 T BUGGIE Série 2-E3

If the lift truck is not on a horizontal ground, to fix so that it does not descend the slope.

⚠ *The lift truck must be towed at very slow speed (less than 5 kph) over the shortest possible distance (less than 100 m).*

- To tow a lift truck, the wheel reducers 1 (fig. G6/1) must be unlocked to avoid deteriorating the hydrostatic transmission. Towing the lift truck must be carried out by means of a rigid drawbar, because the lift truck is uncoupled from its braking system after unlocking the wheel reducers.

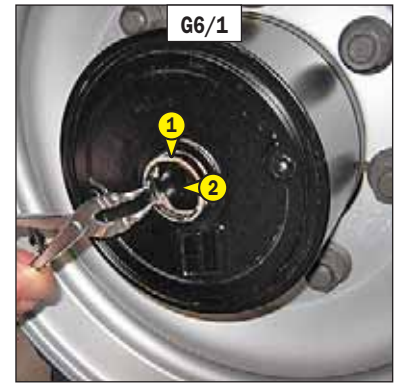

UNLOCKING THE FRONT WHEEL REDUCERS

Carry out this operation on both front wheel reducers.

- Place a container under the reducer.
- Disassemble the retaining ring 1 (fig. G6/1).
- Remove the plug 2 (fig. G6/1), a little oil will then escape.
- Put a screw HM 6 x .. onto the threading of the drive shaft 3 (fig. G6/2).
- Remove the drive shaft and protect it with a clean cloth.
- Reassemble the plug 2 (fig. G6/1) and the retaining ring 1 (fig. G6/1) so as to protect the wheel reducers during the towing.



TOWING THE LIFT TRUCK

- Untighten the hand brake.
- Turn up the warning lights (option).
- As the steering booster is lacking, operate slowly and energetically the steering wheel. Avoid abrupt movements and jerks.
- After towing, proceed in the reverse order to lock the wheel reducers.

NOTE : When reassembling, ensure that the drive shaft grooves and the gears coincide without forcing.

- Top up the level of oil in the wheel reducers (see : 3 - MAINTENANCE : B3 - FRONT WHEELS REDUCERS OIL LEVEL).

MH 20-4 T BUGGIE Série 2-E3
 MH 25-4 T BUGGIE Série 2-E3

If the lift truck is not on a horizontal ground, to fix so that it does not descend the slope.

⚠ *The lift truck must be towed very slowly (less than 5 km/h) and for as short a distance as possible (less than 100 m).*

- To tow a lift truck, the wheel reducers (fig. G6/3) and the high pressure limiters 4 (fig. G6/3) must be unlocked to avoid deteriorating the hydrostatic transmission. Towing the lift truck must be carried out by means of a rigid drawbar, because the lift truck is uncoupled from its braking system after unlocking the wheel reducers.

UNLOCKING THE FRONT WHEEL REDUCERS

Carry out this operation on both front wheel reducers.

- Place a container under the reducer.
- Disassemble the retaining ring 1 (fig. G6/1).
- Remove the plug 2 (fig. G6/1), a little oil will then escape.
- Put a screw HM 6 x .. onto the threading of the drive shaft 3 (fig. G6/2).
- Remove the drive shaft and protect it with a clean cloth.
- Reassemble the plug 2 (fig. G6/1) and the retaining ring 1 (fig. G6/1) so as to protect the wheel reducers during the towing.

UNLOCKING THE HYDROSTATIC TRANSMISSION 4 (fig. G6/3)

- Loosen the nuts 5 (fig. G6/4) by two turns at the most.

TOWING THE LIFT TRUCK

- Untighten the hand brake.
- Turn up the warning lights (option).
- As the steering booster is lacking, operate slowly and energetically the steering wheel. Avoid abrupt movements and jerks.
- After towing, proceed in the reverse order to lock the wheel reducers and the high pressure limiters.

NOTE: When reassembling, ensure that the drive shaft grooves and the gears coincide without forcing.

- Top up the level of oil in the wheel reducers (see: 3 - MAINTENANCE: B3 - FRONT WHEELS REDUCERS OIL LEVEL).

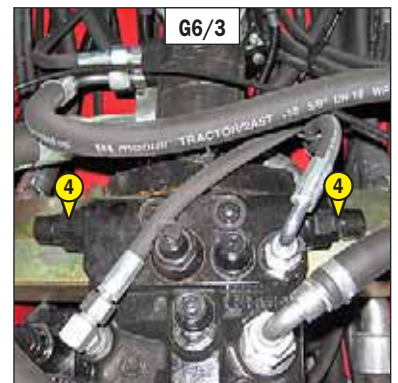
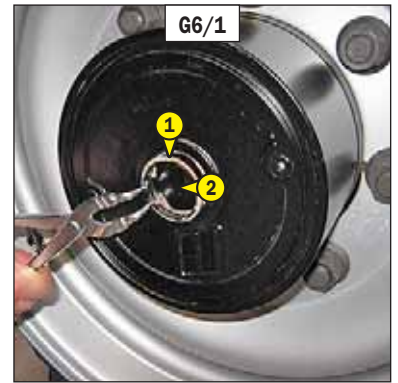

G7 - LIFT TRUCK

SLING

- Take into account the position of the lift truck gravity center for lifting (fig. G7/1).

A = 970 mm	B = 830 mm	MSI 20 T Série 2-E3	MSI 20 T BUGGIE Série 2-E3
A = 1040 mm	B = 760 mm	MSI 25 T Série 2-E3	MSI 25 T BUGGIE Série 2-E3
A = 1120 mm	B = 680 mm	MSI 30 T Série 2-E3	MSI 30 T BUGGIE Série 2-E3
A = 1160 mm	B = 640 mm	MSI 35 T Série 2-E3	MSI 35 T BUGGIE Série 2-E3
A = 960 mm	B = 840 mm	MH 20-4 T BUGGIE Série 2-E3	
A = 1020 mm	B = 780 mm	MH 25-4 T BUGGIE Série 2-E3	

- Place the hooks in the fastening points provided (fig. G7/2 and G7/3).

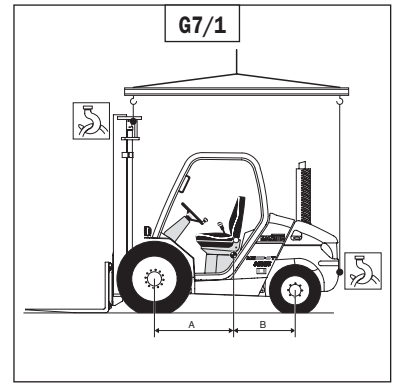

⚠ Ensure that the safety instructions connected to the platform are respected before the loading of the lift truck and that the driver of the means of transport is informed about the dimensions and the weight of the lift truck (see : 2 - DESCRIPTION : CHARACTERISTICS).

⚠ Ensure that the platform has got dimensions and a load capacity sufficient for transporting the lift truck. Check also the pressure on the contact surface allowable for the platform in connection with the lift truck.

⚠ For lift trucks equipped with a turbo-charged I.C. engine, block off the exhaust outlet to avoid rotation of the turbo shaft without lubrication when transporting the vehicle.

LOAD THE LIFT TRUCK

- Block the wheels of the platform.
- Fix the loading ramps so that you obtain an angle as little as possible to lift the lift truck.
- Load the lift truck parallel to the platform.
- Stop the lift truck (see : 1 - OPERATING AND SAFETY INSTRUCTIONS : DRIVING INSTRUCTIONS UNLADEN AND LADEN).

STOW THE LIFT TRUCK

- Fix the chocks to the platform at the front and at the back of each tyre (fig. G8/1).
- Fix also the chocks to the platform in the inside of each tyre (fig. G8/2).
- Stow the lift truck onto the semi-trailer with sufficiently resistant ropes. To the front by passing above the articulation fittings 1 (fig. G8/3) of the mast and to the back onto the towing pin 2 (fig. G8/4).
- Tighten the ropes (fig. G8/5).

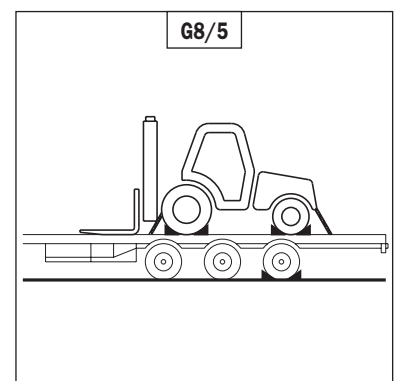
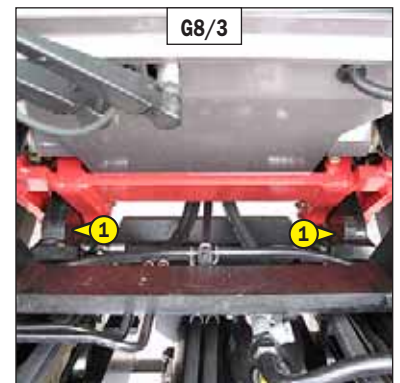
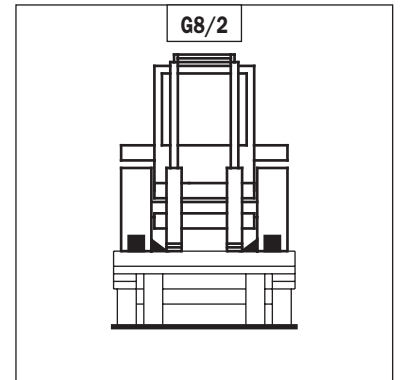
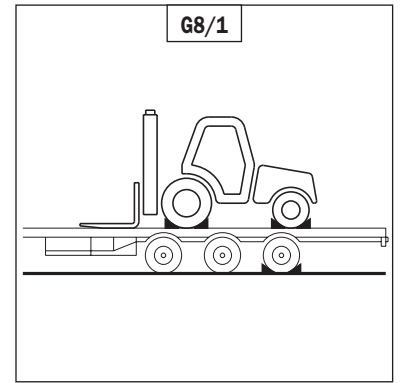

***4 - ADAPTABLE
ATTACHMENTS
IN OPTION ON
THE RANGE***

TABLE OF CONTENTS

INTRODUCTION	4-5
TECHNICAL SPECIFICATIONS OF ATTACHMENTS	4-6
ATTACHMENT SHIELDS	4-14

INTRODUCTION

- Your lift truck must be used with interchangeable equipment. These items are called: ATTACHMENTS.
- A wide range of attachments, specially designed and perfectly suitable for your lift truck is available and guaranteed by MANITOU.
- The attachments are delivered with a load chart concerning your lift truck. The operator's manual and the load chart should be kept in the places provided in the lift truck. For standard attachments, their use is governed by the instructions contained on this notice.
- Some particular uses require the adaptation of the attachment which is not provided in the price-listed options. Optional solutions exist, consult your dealer.

 **All attachments with a suspended load (winch, crane jib, crane jib with winch, hook, etc.) MUST be used with a lift truck equipped with a hydraulic movement cut-out device. In this case, the movement cut-out must be switched on and the transverse attitude perfectly horizontal.**

 **Only attachments approved by MANITOU are to be used on our lift trucks (see : 4 - ADAPTABLE ATTACHMENTS IN OPTION ON THE RANGE : TECHNICAL SPECIFICATIONS OF ATTACHMENTS). The manufacturer's liability will be denied in case of modification or of attachment adaptation carried out without his knowing it.**

 **Maximum loads are defined by the capacity of a lift truck taking account of the attachment's mass and centre of gravity. In the event of the attachment having less capacity than the lift truck, never exceed this limit.**

TECHNICAL SPECIFICATIONS OF ATTACHMENTS

- * : Double mast with all-round vision
- ** : Double mast with total free-acting lift
- *** : Triple mast with total free-acting lift
- **** : Triple mast without free-acting lift

STANDARDISED SIDE-SHIFT CARRIAGE			
MSI 20 T Série 2-E3 MSI 20 T BUGGIE Série 2-E3 MSI 25 T Série 2-E3 MSI 25 T BUGGIE Série 2-E3 MH 20-4 T BUGGIE Série 2-E3 MH 25-4 T BUGGIE Série 2-E3			
	TDL 2T5 L 1260 FEM2	TDL 2T5 L 1470 FEM2	TDL 2T5 L 1580 FEM2
PART NUMBER	571456*	571460*	571464*
	571457**	571461**	571465**
	571458***	571462***	571466***
	571463****		
Nominal load capacity	2500 kg	2500 kg	2500 kg
Side-shift	2 x 100 mm	2 x 100 mm	2 x 100 mm
Width	1260 mm	1470 mm	1580 mm
Weight	85 kg	101 kg	105 kg

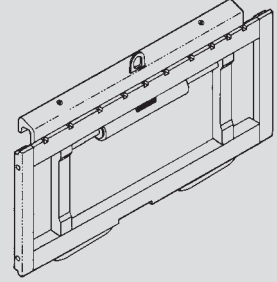

STANDARDISED SIDE-SHIFT CARRIAGE			
MSI 30 T Série 2-E3 MSI 30 T BUGGIE Série 2-E3 MSI 35 T Série 2-E3 MSI 35 T BUGGIE Série 2-E3			
	TDL 3T5 L 1260 FEM2	TDL 3T5 L 1470 FEM2	TDL 3T5 L 1580 FEM2
PART NUMBER	751666*	556386*	556256*
	751667**	570198**	570199**
	751668***	570195***	570196***
Nominal load capacity	3000 kg	3000 kg	3000 kg
Side-shift	2 x 100 mm	2 x 100 mm	2 x 100 mm
Width	1260 mm	1470 mm	1580 mm
Weight	110 kg	192 kg	200 kg

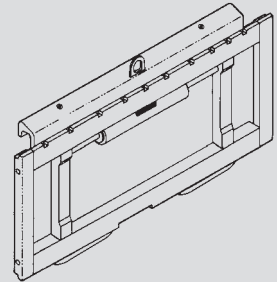

STANDARDISED FORK			
MSI 20 T Série 2-E3 MSI 20 T BUGGIE Série 2-E3 MSI 25 T Série 2-E3 MSI 25 T BUGGIE Série 2-E3 MH 20-4 T BUGGIE Série 2-E3 MH 25-4 T BUGGIE Série 2-E3			
PART NUMBER	415689	415691	415692
Section	100 x 40 x 1100 mm	100 x 40 x 1200 mm	100 x 40 x 1500 mm
Weight	43 kg	44 kg	60 kg
PART NUMBER	415330		
Section	125 x 45 x 1200 mm		
Weight	65 kg		

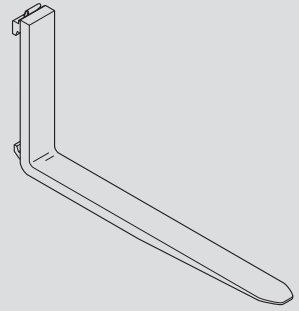

STANDARDISED FORK			
MSI 30 T Série 2-E3 MSI 30 T BUGGIE Série 2-E3			
PART NUMBER	415690	415693	415694
Section	100 x 45 x 1100 mm	100 x 45 x 1200 mm	100 x 45 x 1500 mm
Weight	55 kg	58 kg	72 kg
PART NUMBER	415449		
Section	150 x 50 x 1200 mm		
Weight	100 kg		

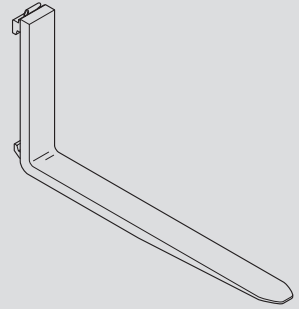

STANDARDISED FORK			
MSI 35 T Série 2-E3 MSI 35 T BUGGIE Série 2-E3			
PART NUMBER	415566	415618	415125
Section	125 x 45 x 1100 mm	125 x 45 x 1200 mm	125 x 45 x 1500 mm
Weight	68 kg	72 kg	88 kg
PART NUMBER	415449		
Section	150 x 50 x 1200 mm		
Weight	100 kg		

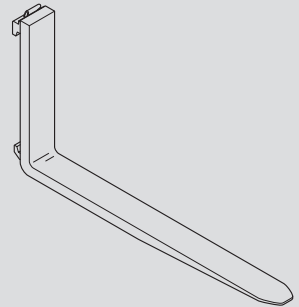

LOAD BACK REST			
MSI 20 T Série 2-E3 MSI 20 T BUGGIE Série 2-E3 MSI 25 T Série 2-E3 MSI 25 T BUGGIE Série 2-E3 MH 20-4 T BUGGIE Série 2-E3 MH 25-4 T BUGGIE Série 2-E3			
PART NUMBER	556005	555323	556007
Width	1260 mm	1470 mm	1580 mm
Weight	37 kg	41 kg	43 kg

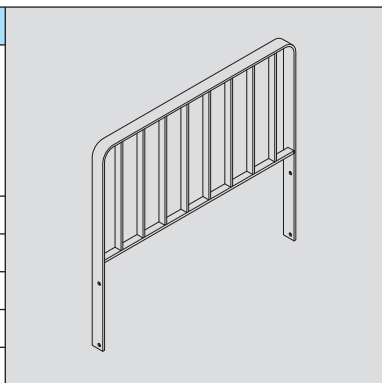

LOAD BACK REST			
MSI 30 T Série 2-E3 MSI 30 T BUGGIE Série 2-E3 MSI 35 T Série 2-E3 MSI 35 T BUGGIE Série 2-E3			
PART NUMBER	556008	555325	556010
Width	1260 mm	1470 mm	1580 mm
Weight	39 kg	41 kg	42 kg

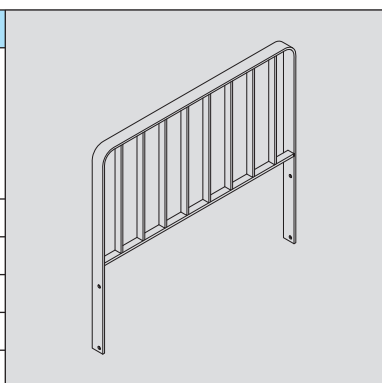

DIGGING BUCKET			
MSI 20 T Série 2-E3 MSI 20 T BUGGIE Série 2-E3 MSI 25 T Série 2-E3 MSI 25 T BUGGIE Série 2-E3 MH 20-4 T BUGGIE Série 2-E3 MH 25-4 T BUGGIE Série 2-E3			
	SP 500-25N A.D. FEM2	SP 500-25N L.A.D. FEM2	
PART NUMBER	751440	751442	
Rated capacity	540L	487L	
Width	1648 mm	2022 mm	
Weight	420 kg	450 kg	

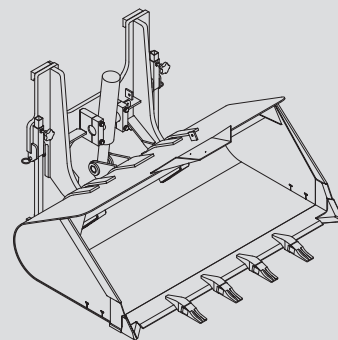

DIGGING BUCKET			
MSI 20 T Série 2-E3 MSI 20 T BUGGIE Série 2-E3 MSI 25 T Série 2-E3 MSI 25 T BUGGIE Série 2-E3 MH 20-4 T BUGGIE Série 2-E3 MH 25-4 T BUGGIE Série 2-E3			
	SP 500-25N S.D. FEM2	SP 500-25N L.S.D. FEM2	
PART NUMBER	751436	751437	
Rated capacity	540L	487L	
Width	1648 mm	2022 mm	
Weight	420 kg	450 kg	

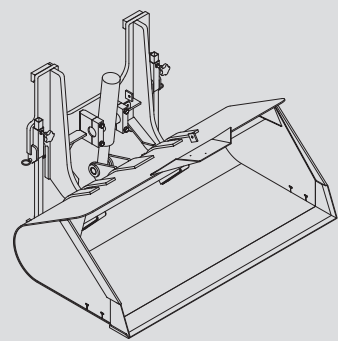

DIGGING BUCKET			
MSI 30 T Série 2-E3 MSI 30 T BUGGIE Série 2-E3 MSI 35 T Série 2-E3 MSI 35 T BUGGIE Série 2-E3			
	SP 500-30N A.D. FEM3	SP 500-30N L.A.D. FEM3	
PART NUMBER	751441	751443	
Rated capacity	540L	487L	
Width	1648 mm	2022 mm	
Weight	420 kg	450 kg	

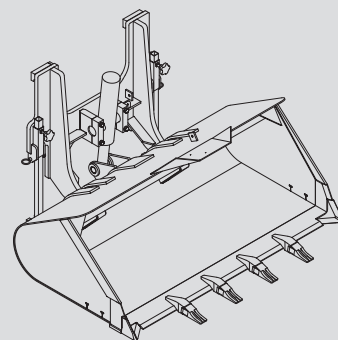

DIGGING BUCKET			
MSI 30 T Série 2-E3 MSI 30 T BUGGIE Série 2-E3 MSI 35 T Série 2-E3 MSI 35 T BUGGIE Série 2-E3			
	SP 500-30N S.D. FEM3	SP 500-30N L.S.D. FEM3	
PART NUMBER	751438	751439	
Rated capacity	540L	487L	
Width	1648 mm	2022 mm	
Weight	420 kg	450 kg	

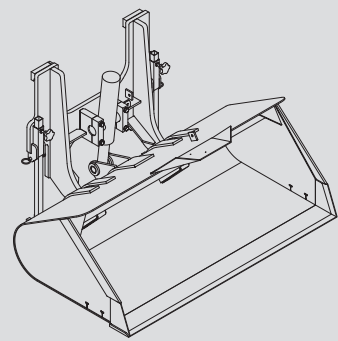

GRAIN BUCKET			
MSI 20 T Série 2-E3 MSI 20 T BUGGIE Série 2-E3 MSI 25 T Série 2-E3 MSI 25 T BUGGIE Série 2-E3 MH 20-4 T BUGGIE Série 2-E3 MH 25-4 T BUGGIE Série 2-E3			
	BA 1000 25N FEM 2A	BA 1500 25N FEM 2A	BA 2000 25N FEM 2A
PART NUMBER	751430	751431	751432
Rated capacity	1333L	1971L	2580L
Width	2022 mm	2022 mm	2022 mm
Weight	470 kg	600 kg	700 kg

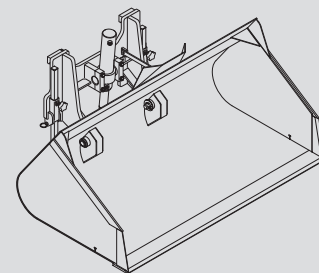

GRAIN BUCKET			
MSI 30 T Série 2-E3 MSI 30 T BUGGIE Série 2-E3 MSI 35 T Série 2-E3 MSI 35 T BUGGIE Série 2-E3			
	BA 1000 30N FEM 3A	BA 1500 30N FEM 3A	BA 2000 30N FEM 3A
PART NUMBER	751433	751434	751435
Rated capacity	1333L	1971L	2580L
Width	2022 mm	2022 mm	2022 mm
Weight	480 kg	610 kg	700 kg

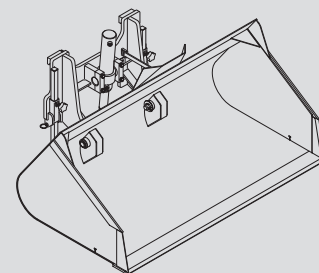

NORMALIZED TILTING FORK CARRIAGE (ON TILTABLE CARRIAGE TI)			
MSI 25 T Série 2-E3 MSI 25 T BUGGIE Série 2-E3 MSI 30 T Série 2-E3 MSI 30 T BUGGIE Série 2-E3 MH 20-4 T BUGGIE Série 2-E3 MH 25-4 T BUGGIE Série 2-E3			
	PFB 25 N TI L 1260	PFB 25 N TI L 1470	PFB 25 N TI L 1580
PART NUMBER	570513	570514	653843
Rated capacity	2500 kg	2500 kg	2500 kg
Width	1260 mm	1470 mm	1580 mm
Weight	87 kg	104 kg	108 kg

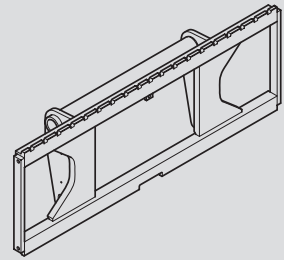

NORMALIZED TILTING FORK CARRIAGE (ON TILTABLE CARRIAGE TI)			
MSI 35 T Série 2-E3 MSI 35 T BUGGIE Série 2-E3			
	PFB 35 N TI L 1260	PFB 35 N TI L 1470	PFB 35 N TI L 1580
PART NUMBER	653844	653845	653846
Rated capacity	3500 kg	3500 kg	3500 kg
Width	1260 mm	1470 mm	1580 mm
Weight	114 kg	133 kg	138 kg

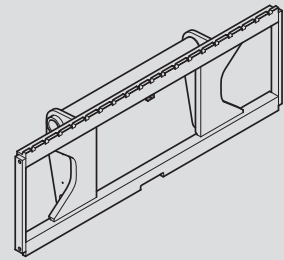

STANDARDISED SIDE-SHIFT CARRIAGE (ON TILTABLE CARRIAGE TI)			
MSI 25 T Série 2-E3 MSI 25 T BUGGIE Série 2-E3 MSI 30 T Série 2-E3 MSI 30 T BUGGIE Série 2-E3 MH 20-4 T BUGGIE Série 2-E3 MH 25-4 T BUGGIE Série 2-E3			
	TDL 2T5 L 1260	TDL 2T5 L 1470	TDL 2T5 L 1580
REFERENCE	752182	752183	752184
Nominal load capacity	2500 kg	2500 kg	2500 kg
Side-shift	2 x 100 mm	2 x 100 mm	2 x 100 mm
Width	1260 mm	1470 mm	1580 mm
Weight	67 kg	88 kg	93 kg

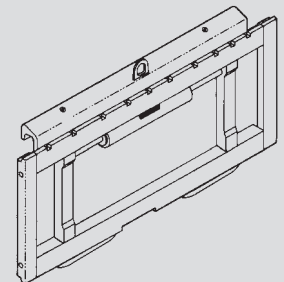

LOAD BACK REST (ON TILTABLE CARRIAGE TI)			
MSI 25 T Série 2-E3 MSI 25 T BUGGIE Série 2-E3 MSI 30 T Série 2-E3 MSI 30 T BUGGIE Série 2-E3 MH 20-4 T BUGGIE Série 2-E3 MH 25-4 T BUGGIE Série 2-E3			
PART NUMBER	570518	570519	556007
Width	1260 mm	1470 mm	1580 mm
Weight	38 kg	42 kg	44 kg

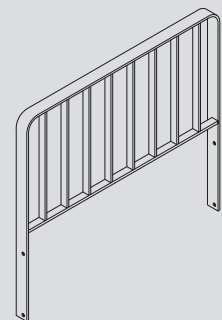

STANDARDISED FORK (ON TILTABLE CARRIAGE TI)

MSI 20 T Série 2-E3 MSI 20 T BUGGIE Série 2-E3
 MSI 25 T Série 2-E3 MSI 25 T BUGGIE Série 2-E3
 MSI 30 T Série 2-E3 MSI 30 T BUGGIE Série 2-E3
 MH 20-4 T BUGGIE Série 2-E3
 MH 25-4 T BUGGIE Série 2-E3

PART NUMBER	415689	415691	415692
Section	100 x 40 x 1100 mm	100 x 40 x 1200 mm	100 x 40 x 1500 mm
Weight	43 kg	44 kg	60 kg
PART NUMBER	415330	415565	415164
Section	125 x 45 x 1200 mm	125 x 40 x 1100 mm	125 x 40 x 1200 mm
Weight	65 kg	54 kg	56 kg

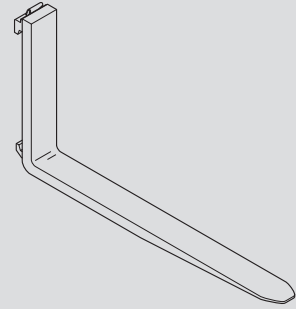
**STANDARDISED FORK (ON TILTABLE CARRIAGE TI)**

MSI 35 T Série 2-E3 MSI 35 T BUGGIE Série 2-E3

PART NUMBER	415690	415693	415694
Section	100 x 45 x 1100 mm	100 x 45 x 1200 mm	100 x 45 x 1500 mm
Weight	55 kg	58 kg	72 kg
PART NUMBER	415449		
Section	150 x 50 x 1200 mm		
Weight	100 kg		

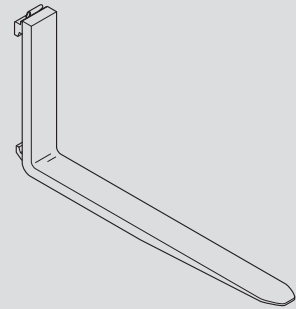
**LOADING BUCKET (ON TILTABLE CARRIAGE TI)**

MSI 25 T Série 2-E3 MSI 25 T BUGGIE Série 2-E3
 MSI 30 T Série 2-E3 MSI 30 T BUGGIE Série 2-E3
 MH 20-4 T BUGGIE Série 2-E3
 MH 25-4 T BUGGIE Série 2-E3

	CBR 500 L1500	CBR 600 L1500	
PART NUMBER	571991	570614	
Rated capacity	496L	583L	
Width	1500 mm	1500 mm	
Weight	254 kg	274 kg	

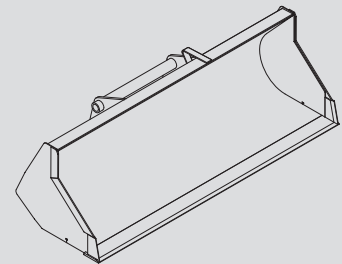
**BUILDING BUCKET (ON TILTABLE CARRIAGE TI)**

MSI 30 T Série 2-E3 MSI 30 T BUGGIE Série 2-E3
 MH 20-4 T BUGGIE Série 2-E3
 MH 25-4 T BUGGIE Série 2-E3

	CBC 500 L 1500		
PART NUMBER	654474		
Rated capacity	519L		
Width	1500 mm		
Weight	276 kg		

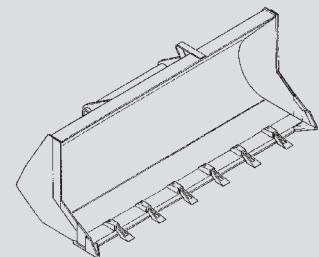

GRAIN BUCKET (ON TILTABLE CARRIAGE TI)

MSI 30 T Série 2-E3 MSI 30 T BUGGIE Série 2-E3
MH 20-4 T BUGGIE Série 2-E3
MH 25-4 T BUGGIE Série 2-E3

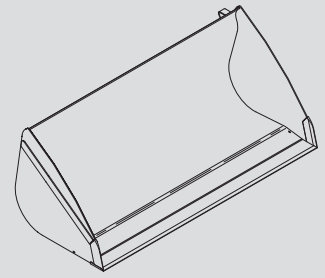
**CBA 900 L 1500 S3****PART NUMBER****570543**

Rated capacity

878L

Width

1500 mm

Weight

367 kg

GRAB BUCKET (ON TILTABLE CARRIAGE TI)

MSI 30 T Série 2-E3 MSI 30 T BUGGIE Série 2-E3
MH 20-4 T BUGGIE Série 2-E3
MH 25-4 T BUGGIE Série 2-E3

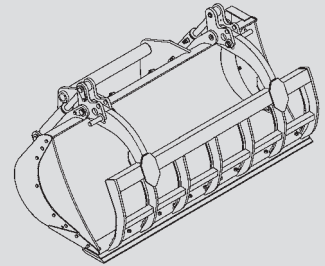
**CBG 1500 S4****PART NUMBER****751425**

Rated capacity

0,8 m³

Width

1500 mm

Weight

458 kg

ATTACHMENT SHIELDS

FORK PROTECTOR

FORK PROTECTOR			
PART NUMBER	227801		

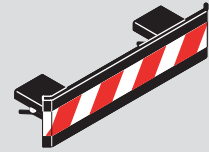

BUCKET PROTECTOR

NOTE: Always ensure that the width of the protector you choose is less than or equal to the width of the bucket.

PART NUMBER	206734	206732	206730
Width	1375 mm	1500 mm	1650 mm
PART NUMBER	235854	206728	206726
Width	1850 mm	1950 mm	2000 mm
PART NUMBER	223771	223773	206724
Width	2050 mm	2100 mm	2150 mm
PART NUMBER	206099	206722	223775
Width	2250 mm	2450 mm	2500 mm

