

OPERATION MANUAL
Self-propelled Wheel type Aerial platform
SP18AJ/SP21AJ

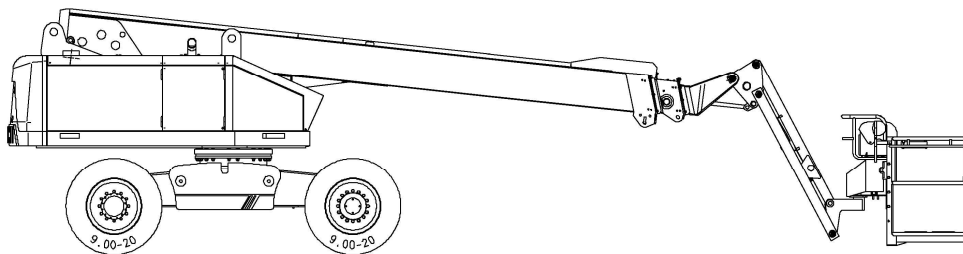

SP18AJ/SP21A

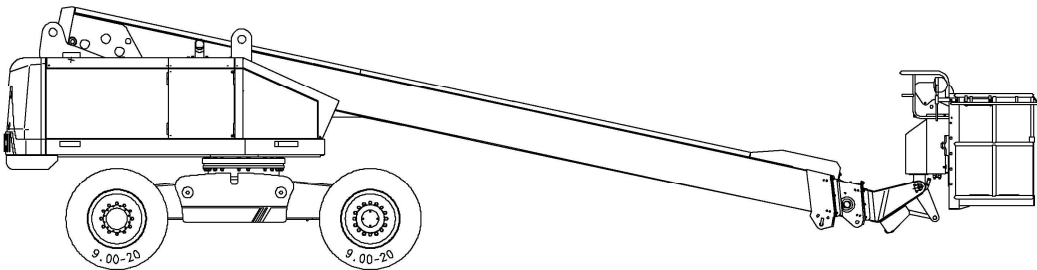

Important : Please read this operation manual before operating the machine.



1152 RYOKE, AGE0, SAITAMA, JAPAN

Introduction

Thank you very much for making your purchase from Aichi Corporation.

This manual describes the correct operation and handling procedures for the self-propelled wheel type aerial platforms SP18AJ / ISP60J and SP21AJ / ISP70J. Reading and reference to this manual will ensure the maximum operational efficiency of this machine.

Operation of this machine not in accordance with the instructions in this manual may lead to problems, resulting in damage and increasing risk of danger. Please be sure to read and understand this manual before using this machine.

- n Always keep this manual and the record of Aichi pre-delivery function tests with the machine.
- n When you transfer the use or ownership of the machine, please attach this manual to the machine for the next user.
- n For any doubts you may have about handling, inspection or spare parts, please do not hesitate to contact our business office or the authorized service shop nearest to you. In this case, you are requested to quote the model, serial number, manufactured date marked on the serial number plate.
- n Use only the spare parts approved by the manufacturer, particularly for load-supporting and safety-related components.
- n Do not make any modifications to the machine without obtaining the manufacturer's approval. The approved agent should conduct the design check, the manufacturing check as well as the practical tests, if any modifications that would affect the stability, strength or performance of the machine are made. Detail of major alterations or repairs must be recorded in the service manual.
- n The user of this machine shall obtain the guidance and approval of the manufacturer in the event of any special working method or conditions, which are outside those specified by the manufacturer.
- n Your attention is drawn to certain changes in illustration or contents, which may be made without notice.

Table of Contents

I	Qualifications of Operator	1
II	Name of Components	2
III	Specifications	3
	1. Main specifications	3
	2. Work range diagram	5
	1. Counterweight table	5
IV	Periodic Inspections	9
V	Pre-start Checks	10
	1. Pre-start Checks	10
	2. Pre-start checks for Work range limit system	14
VI	For Safety	18
	1. Before operation	18
	2. During operation	21
	3. After operation	29
VII	Machine setting up	31
VIII	Safety Devices	32
IX	Control Panels	33
	1. Lower control panel	33
	2. Upper control panel	34
	3. Pictorial symbols	35
X	Operating Method	37
	1. Engine start operation	37
	1.1 Engine start operation from Lower control	37

1.2	Engine start operation from Upper control	39
2.	Engine stop operation	40
3.	Lower control (Operation from ground)	41
3.1	Boom and Fly jib operation	41
3.1.1	Boom raising and lowering operation	41
3.1.2	Boom rotating operation	42
3.1.3	Boom telescoping operation	42
3.1.4	Fly jib operation	42
3.2	Emergency stop operation	43
3.3	Emergency pump operation	44
3.4	Platform level adjustment	45
3.5	Bleeding air from the platform leveling system	46
3.6	Indicator lights	47
3.7	Limit cancel switch operation	48
4.	Upper control (Operation from platform)	49
4.1	Foot-switch	49
4.2	Travel operation	50
4.2.1	Forward and reverse	51
4.2.2	Left and right turns	51
4.2.3	Travel speed select switch	52
4.3	Boom and Fly jib operation	52
4.3.1	Boom raising and lowering operation	53
4.3.2	Boom rotating operation	53
4.3.3	Boom telescoping operation	53
4.3.4	Fly jib operation	54
4.4	Horizontal and vertical movement operation	54
4.5	Platform rotating operation	57
4.6	Platform level adjusting operation	57

4.7	Emergency stop operation	58
4.8	Emergency pump operation	59
4.9	Horn operation	59
4.10	Indicator lights	60
XI	Operating Point	61
XII	Towing	62
XIII	Transportation	64
1.	When using loading ramp	64
2.	When hoisting	65
XIV	Lubrication	66
1.	Recommended lubricants	66
2.	Lubricating points and intervals	67
2.1	Lubricate every 100 hours or one month	67
2.2	Change oil every 1,200 hours or 12 months	68
XV	Daily Care	69
1.	Hydraulic oil	69
1.1	Replenishing	69
1.2	Changing oil	69
2.	Gear oil for Rotation gearbox	70
3.	Gear oil for Travel gearbox	70
4.	Engine	70
5.	Wire ropes	71
6.	Fuses	71
7.	Hydraulic hoses	72

XVI Storage for Long Periods **73**

XVII Optional Equipment Operating Method **75**

 1. Work light 75

 2. Rotating beacon 75

 3. AC power outlet 75

I Qualifications of Operator

The operator of this machine must receive safety training to ensure safe operation.

Safety training

Incorrect use of this machine may cause serious injury or death.

All personnel who operate this machine are requested to receive safety training. And only trained and authorized personnel are permitted to operate this machine.

(For information on safety training, use this manual.)

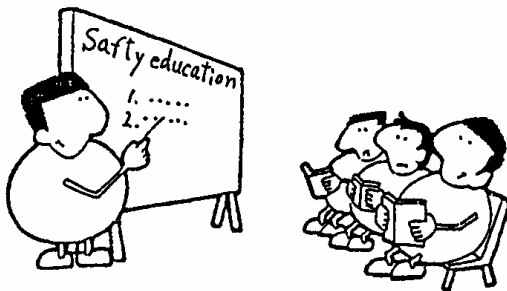

Safety training!

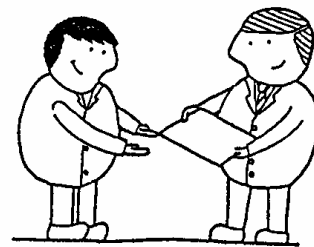

Certificate of training course

II Name of Components

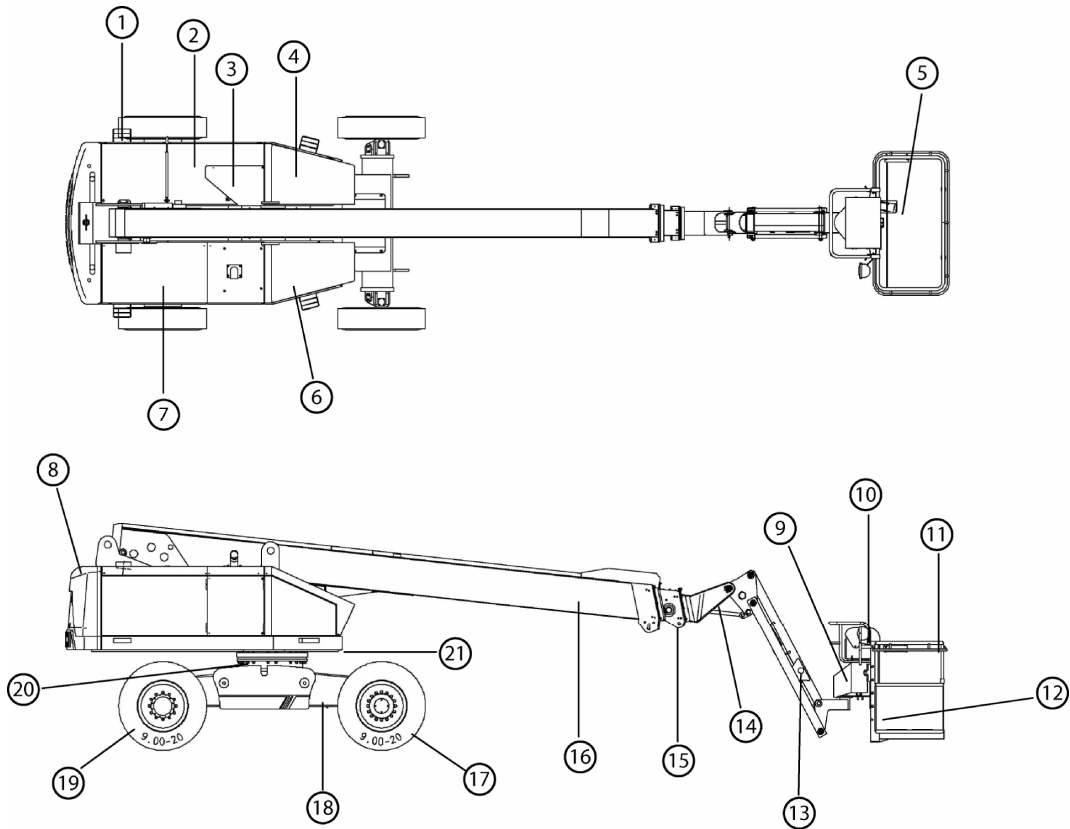

No.	Part Name	No.	Part name
1	Lower control	12	Manual holder
2	Fuel tank	13	Fly jib
3	Hydraulic oil tank	14	3 rd boom section
4	Rotation lock pin (Located inside the cover.)	15	2 nd boom section
5	Foot switch	16	1 st boom section
6	Rotation gearbox (Located inside the cover.)	17	Rear wheel
7	Engine compartment	18	Chassis
8	Turntable	19	Front wheel
9	Platform rotation device	20	Rotation bearing
10	Upper control box	21	Serial number plate
11	Platform

III Specifications SP18/21A

1. Main specifications

<i>Model</i>			<i>SP18A / ISP60</i>	<i>SP21A / ISP70</i>	
Dimensions	Overall length		9.17 m (30 ft – 1 in)	10.15 m (33 ft – 4 in)	
	Overall width	For STD 6 feet platform	2.43 m (8 ft – 0 in)	Ⓕ	
		For Optional 8 feet platform	2.58 m (8 ft – 6 in)	Ⓕ	
	Overall height		2.64 m (8 ft – 8 in)	Ⓕ	
	Wheelbase		2.50 m (8 ft – 2 in)	Ⓕ	
	Minimum turning radius (Outside)		5.92 m (19 ft – 5 in)	Ⓕ	
	Tail swing		1.15 m (3 ft – 9 in)	Ⓕ	
Minimum ground clearance		255 mm (10 in)	Ⓕ		
Tires	Foam filled tires (Size)		15×19.5	Ⓕ	
	Air filled tires (Option for USA)	Size	15×19.5	Ⓕ	
		Air pressure	7.6 bar (110 PSI)	Ⓕ	
Weight	Gross weight	CE Spec.	12,300 kg (27,200 LBS)	14,500 kg (32,000 LBS)	
		USA Spec.	Machine with foam filled tires	10,800 kg (23,800 LBS)	13,700 kg (30,200 LBS)
			Machine with air filled tires	10,900 kg (24,000 LBS)	13,400 kg (29,500 LBS)
	Max. tire loading force	CE Spec.	9,800 kg (21,600 LBS)	11,400 kg (25,100 LBS)	
		USA Spec.	Machine with foam filled tires	8,900 kg (19,600 LBS)	10,700 kg (23,600 LBS)
			Machine with air filled tires	8,800 kg (19,400 LBS)	10,600 kg (23,400 LBS)
Max. tire ground contact pressure		7.0 kg/cm ² (100 PSI)	8.0 kg/cm ² (114 PSI)		
Diesel Engine	Model		ISUZU A-4JB1,PAA-22	Ⓕ	
	Max. output		43.0 kW / 2,400 rpm (57.7 HP / 2,400 rpm)	Ⓕ	
	Max. torque		19.5 kg-m / 1,800 rpm (141 ft-lbs / 1,800 rpm)	Ⓕ	
	Displacement		2,771 cc (169 in ³)	Ⓕ	
	Fuel tank capacity		150 liters (39.6 gallons)	Ⓕ	
Duel fuel engine (Option for USA)	Model		GM 3.0 L industrial engine	Ⓕ	
	Max. output	Gasoline	54.1 kW / 2,450 rpm (72.5 HP / 2,450 rpm)	Ⓕ	
		LPG	47.1 kW / 2,450 rpm (63.2 HP / 2,450 rpm)	Ⓕ	
	Max. torque	Gasoline	23.3 kg-m / 2,000 rpm (168 ft-lbs / 2,000 rpm)	Ⓕ	
		LPG	19.1 kg-m / 2,000 rpm (138 ft-lbs / 2,000 rpm)	Ⓕ	
	Displacement		2,966 cc (181 in ³)	Ⓕ	
	Fuel tank capacity		150 liters (39.6 gallons)	Ⓕ	
Battery voltage		24 V	Ⓕ		

<i>Model</i>			<i>SP18A / ISP60</i>	<i>SP21A / ISP70</i>	
Platform	Rated load		227 kg (500 LBS) or 2 persons + Tools 67 kg (148 LBS)	β	
	Max. allowable manual side force		400 N (41 kg) (90 LBS)	β	
	Max. platform floor height		18.2 m (59ft – 9in)	21.0 m (68ft – 11in)	
	Max. outreach		16.7 m (54ft -9 in)	18.6 m (61ft – 0in)	
	Rotation angle		180 degrees	β	
Max. allowable tilt angle	CE Spec.	5 degrees	β		
	USA Spec.	Level (0 degree)	β		
Max. allowable wind speed		12.5 m/second (28 MPH)	β		
Gradeability		45% (24 degrees)	β		
Boom	Boom angle		-12 ~ +70 degrees	β	
	Boom length		7.43 ~ 17.15 m (24ft – 5in ~ 56ft – 3in)	8.44 ~ 20.19 m (27ft - 8in ~ 66ft - 3in)	
	Boom rotation angle		360 degrees (Continuous)	β	
Actuating speed	Boom elevation (with the boom fully retracted)	Up	40 seconds	β	
		Down	40 seconds	β	
	Boom telescope	Out	35 seconds	45 seconds	
		In	30 seconds	35 seconds	
	Boom rotation (with the outreach set to the minimum.)	CE Spec.	CW	0.75 rpm	0.67 rpm
			CCW	0.75 rpm	0.67 rpm
		USA Spec.	CW	0.75 rpm	0.75 rpm
			CCW	0.75 rpm	0.75 rpm
	Platform rotation	CW	30 seconds	β	
		CCW	30 seconds	β	
	Horizontal movement	Up	200 mm / second (7.9 inches / second)	β	
		Down	200 mm / second (7.9 inches / second)	β	
	Vertical movement	Out	200 mm / second (7.9 inches / second)	β	
		In	200 mm / second (7.9 inches / second)	β	
Traveling	High speed	5.5 km/h (3.42 MPH)	β		
	Mid speed	2.8 km/h (1.74 MPH)	β		
	Low speed	1.3km/h (0.81 MPH)	β		
Hydraulic system	Rated pressure	Travel functions	340 kgf/cm ² (4,800 PSI)	β	
		Boom functions	210 kgf/cm ² (3,000 PSI)	β	
	Hydraulic tank capacity		150 liters (39.6 gallons)	β	
	Recommended hydraulic oil		Shell Tellus oil T22	β	

- NOTE**
- Airborne noise emissions do not exceed a sound pressure level of 85 dB(A) at the operating positions.
 - The vibration emitted by the machine does not exceed 0.5 m/s² (19.7 in/s²) on the work platform.
 - This machine is designed for both indoor and outdoor use.

2. Work range diagram

Rated load: 227 kg (500 LBS).

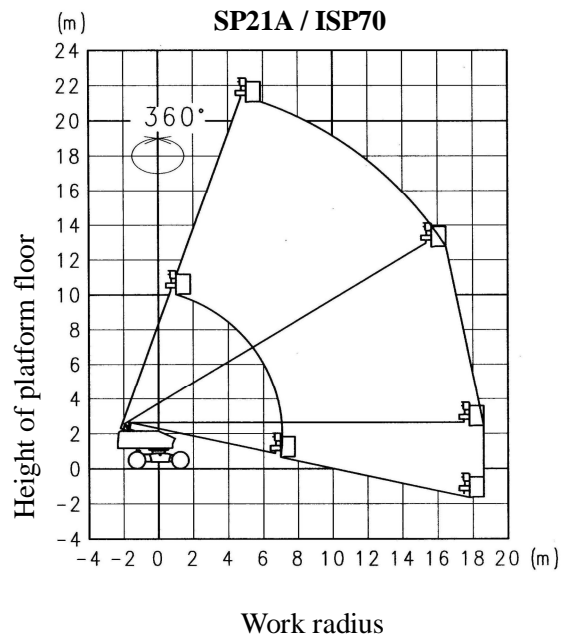
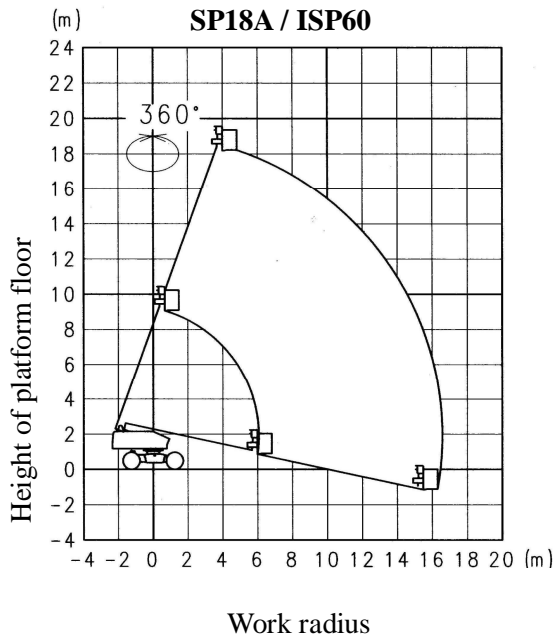

- 1) The boom deflection is not taken into account in the above work range diagram.
- 2) The work range is the same in any boom-rotated directions.
- 3) It is assumed that the machine is on firm and level surface, and that the wind velocity is less than 12.5 m/sec (28 MPH).
- 4) The maximum allowable manual side force of the platform is 41 kg (90 LBS).

3. Counterweight table

The weight of the counterweight is marked on each counterweight.

Model	Specification		Number of counterweight						
			On chassis			On Turntable			
			550 kg 1,213 lbs	75 kg 165 lbs	50 kg 110 lbs	1,850 kg 4,079 lbs	670 kg 1,477 lbs	335 kg 739 lbs	90 kg 198 lbs
SP18A/ ISP60	CE		2	0	0	1	0	2	3
	USA	Air filled tire	0	6	2	1	0	2	0
		Foam filled tire	0	0	0	1	0	2	1
SP21A/ ISP70	CE		4	0	0	1	0	4	5
	USA	Air filled tire	4	0	0	1	0	4	0
		Foam filled tire	4	0	0	1	0	4	0

III Specifications SP18/21AJ

1. Main specifications

<i>Model</i>			<i>SP18AJ / ISP60J</i>	<i>SP21AJ / ISP70J</i>	
Dimensions	Overall length		10.04 m (32 ft – 11 in)	11.57 m (38 ft – 0 in)	
	Overall width	For STD 6 feet platform	2.43 m (8 ft – 0 in)	Ⓕ	
		For Optional 8 feet platform	2.58 m (8 ft – 6 in)	Ⓕ	
	Overall height		2.64 m (8 ft – 8 in)	Ⓕ	
	Wheelbase		2.50 m (8 ft – 2 in)	Ⓕ	
	Minimum turning radius (Outside)		5.92 m (19 ft – 5 in)	Ⓕ	
	Tail swing		1.15 m (3 ft – 9 in)	Ⓕ	
Minimum ground clearance		255 mm (10 in)	Ⓕ		
Tires	Foam filled tires (Size)		15×19.5	Ⓕ	
	Air filled tires (Option for USA)	Size	15×19.5	Ⓕ	
		Air pressure	7.6 bar (110 PSI)	Ⓕ	
Weight	Gross weight	CE Spec.	12,300kg (27,200 LBS)	14,700 kg (32,400 LBS)	
		USA Spec.	Machine with foam filled tires	10,900 kg (24,000 LBS)	14,100 kg (31,100 LBS)
			Machine with air filled tires	10,900 kg (24,000 LBS)	13,700 kg (30,200 LBS)
	Max. tire loading force	CE Spec.	9,800 kg (21,600 LBS)	11,400 kg (25,100 LBS)	
		USA Spec.	Machine with foam filled tires	8,800 kg (19,400 LBS)	10,800 kg (23,800 LBS)
			Machine with air filled tires	8,700 kg (19,200 LBS)	10,600 kg (23,400 LBS)
Max. tire ground contact pressure		7.0 kg/cm ² (100 PSI)	8.0 kg/cm ² (114 PSI)		
Diesel Engine	Model		ISUZU A-4JB1,PAA-22	Ⓕ	
	Max. output		43.0 kW / 2,400 rpm (57.7HP / 2,400 rpm)	Ⓕ	
	Max. torque		19.5 kg-m / 1,800 rpm (141 ft-lbs / 1,800 rpm)	Ⓕ	
	Displacement		2,771 cc (169 in ³)	Ⓕ	
	Fuel tank capacity		150 liters (39.6 gallons)	Ⓕ	
Duel fuel engine (Option for USA)	Model		GM 3.0 L industrial engine	Ⓕ	
	Max. output	Gasoline	54.1 kW/ 2,450 rpm (72.5 HP / 2,450 rpm)	Ⓕ	
		LPG	47.1 kW / 2,450 rpm (63.2 HP / 2,450 rpm)	Ⓕ	
	Max. torque	Gasoline	23.3 kg-m / 2,000 rpm (168 ft-lbs / 2,000 rpm)	Ⓕ	
		LPG	19.1 kg-m / 2,000 rpm (138 ft-lbs / 2,000 rpm)	Ⓕ	
	Displacement		2,966 cc (181 in ³)	Ⓕ	
	Fuel tank capacity		150 liters (39.6 gallons)	Ⓕ	
Battery voltage		24 V	Ⓕ		

<i>Model</i>			<i>SP18AJ / ISP60J</i>	<i>SP21AJ / ISP70J</i>	
Platform	Rated load		227 kg (500 LBS) or 2 persons + Tools 67 kg (148 LBS)	Ⓕ	
	Max. allowable manual side force		400 N (41 kg) (90 LBS)	Ⓕ	
	Max. platform floor height		18.2 m (59ft – 9in)	21.0 m (68ft – 11in)	
	Max. outreach		15.8 m (51ft – 10 in)	17.8 m (58ft - 5in)	
	Rotation angle		180 degrees	Ⓕ	
Max. allowable tilt angle	CE Spec.	5 degrees	Ⓕ		
	USA Spec.	Level (0 degree)	Ⓕ		
Max. allowable wind speed		12.5 m/second (28 MPH)	Ⓕ		
Gradeability		45% (24 degrees)	Ⓕ		
Boom and Fly jib	Boom angle		-12 ~ +70 degrees	Ⓕ	
	Boom length		6.91 ~ 15.84 m (22ft – 8in ~ 52ft – 0in)	8.44 ~ 18.69 m (27ft - 8in ~ 61ft - 4in)	
	Boom rotation angle		360 degrees (Continuous)	Ⓕ	
	Fly jib length		1.65 m (5ft - 5 in)	Ⓕ	
	Fly jib articulating angle		-60 ~ +70 degrees	Ⓕ	
Actuating speed	Boom elevation (with the boom fully retracted)	Up	40 seconds	Ⓕ	
		Down	40 seconds	Ⓕ	
	Boom telescope	Out	35 seconds	40 seconds	
		In	25 seconds	30 seconds	
	Boom rotation (with the outreach set to the minimum.)	CE Spec.	CW	0.63 rpm	0.55 rpm
			CCW	0.63 rpm	0.55 rpm
		USA Spec.	CW	0.75 rpm	0.75 rpm
			CCW	0.75 rpm	0.75 rpm
	Fly jib articulation	Up	30 seconds	Ⓕ	
		Down	25 seconds	Ⓕ	
	Platform rotation	CW	30 seconds	Ⓕ	
		CCW	30 seconds	Ⓕ	
	Horizontal movement	Up	200 mm / second (7.9 inches / second)	Ⓕ	
		Down	200 mm / second (7.9 inches / second)	Ⓕ	
	Vertical movement	Out	200 mm / second (7.9 inches / second)	Ⓕ	
		In	200 mm / second (7.9 inches / second)	Ⓕ	
Traveling	High speed	5.5 km/h (3.42 MPH)	Ⓕ		
	Mid speed	2.8 km/h (1.74 MPH)	Ⓕ		
	Low speed	1.3km/h (0.81 MPH)	Ⓕ		
Hydraulic system	Rated pressure	Travel functions	340 kgf/cm ² (4,800 PSI)	Ⓕ	
		Boom functions	210 kgf/cm ² (3,000 PSI)	Ⓕ	
	Hydraulic tank capacity		150 liters (39.6 gallons)	Ⓕ	
	Recommended hydraulic oil		Shell Tellus oil T22	Ⓕ	

- NOTE**
- Airborne noise emissions do not exceed a sound pressure level of 85 dB(A) at the operating positions.
 - The vibration emitted by the machine does not exceed 0.5 m/s² (19.7 in/s²) on the work platform.
 - This machine is designed for both indoor and outdoor use.

2. Work range diagram

Rated load: 227 kg (500 LBS).

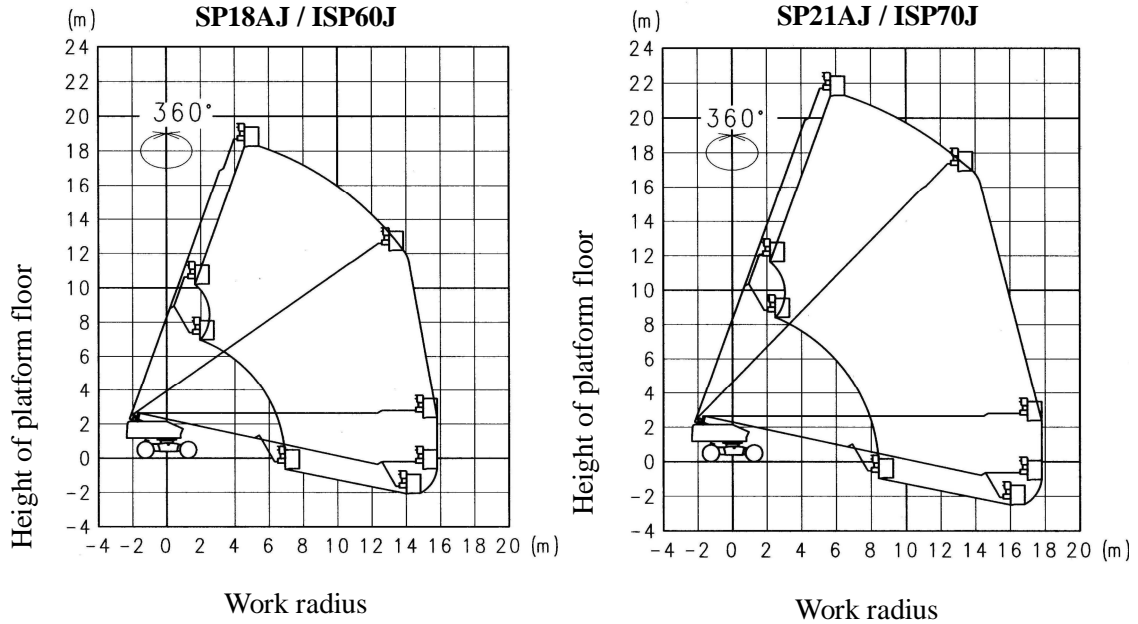

- 1) The boom deflection is not taken into account in the above work range diagram.
- 2) The work range is the same in any boom-rotated directions.
- 3) It is assumed that the machine is on firm and level surface, and that the wind velocity is less than 12.5 m/sec (28 MPH).
- 4) The maximum allowable manual side force of the platform is 41 kg (70 LBS).

3. Counterweight table

The weight of the counterweight is marked on each counterweight.

Model	Specification		Number of counterweight						
			On chassis			On Turntable			
			550 kg 1,213 lbs	75 kg 165 lbs	50 kg 110 lbs	1,850 kg 4,079 lbs	670 kg 1,477 lbs	335 kg 739 lbs	90 kg 198 lbs
SP18AJ / ISP60J	CE		2	0	0	1	0	2	3
	USA	Air filled tire	0	6	0	1	0	2	0
		Foam filled tire	0	0	0	1	0	2	1
SP21AJ / ISP70J	CE		4	2	0	1	0	4	4
	USA	Air filled tire	4	2	0	1	0	4	0
		Foam filled tire	4	2	0	1	0	4	0

IV Periodic Inspections

n Conduct monthly and annual inspections and keep all records for three years.

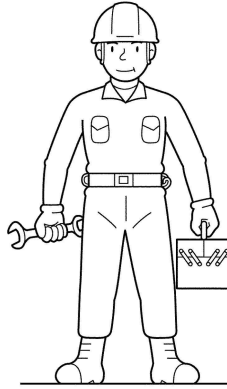

- ADVICE**
- Use the separate service manual for recording the inspection results.
 - For inspections, contact Aichi service shop.

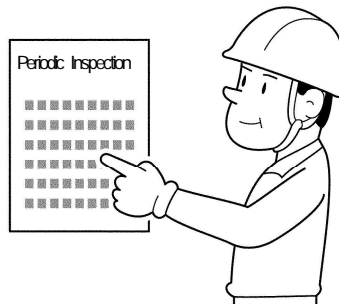

DANGER When the inspections or repairs are conducted under the boom and platform, use safety support to prevent the boom and the platform from unexpected descent.

V Pre-start Checks

1. Pre-start Checks

- n Conduct pre-start checks before using the machine without fail.

Pre-start check must also be conducted before using the machine which:

- has been stored for a long time.
- is a new machine.
- has been serviced or repaired.

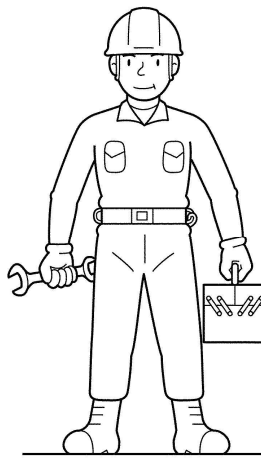

- n Set up the machine on firm and level surface and the following items should be checked thoroughly.

DANGER When inspections or repairs are conducted under the boom and platform, use safety support to prevent the boom and the platform from unexpected descent.

CAUTION If any abnormality is observed, stop using the machine and contact Aichi service shop for inspections.

ADVICE Use only the AICHI genuine parts for repairs.

- (1) Check fuel, engine oil, cooling water and hydraulic oil and replenish, if necessary.



ADVICE Retract and lower the boom fully before checking the hydraulic oil level.

- (2) Check the boom, the platform and the chassis for cracks and deformations.
Also, check each bolt and nut for looseness.

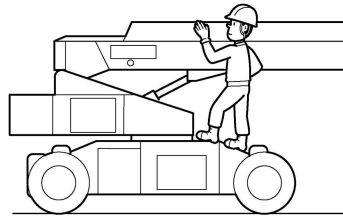

- (3) Check that greasing points are lubricated sufficiently.

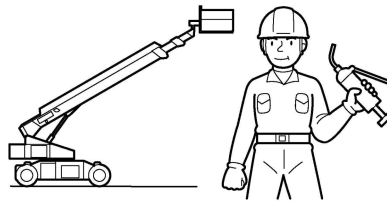

- (4) Check that all decals are clean and readable.



CAUTION Damaged or dirty decals can not be read properly and should be replaced.

- (5) Turn the engine key switch to ON position and make sure that the alarm buzzer sounds three times, just after turning on.

DANGER If the buzzer does not sound properly, the machine is faulty. Do not use the faulty machine and contact Aichi service shop for inspections.

- (6) Warm up the engine, then operate the machine from the lower control and make sure that all of the functions are smooth without any abnormal noise.

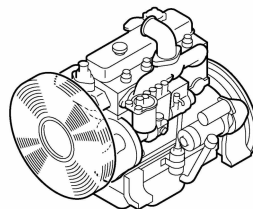

CAUTION Check the functions by operating the machine from the lower control first, then from the upper control.

(7) Check the safety devices and make sure that all of the devices work properly.

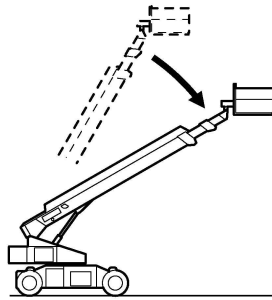

CAUTION Always check that the work range limit system is working correctly. (For detail, see the following clause of “2. Pre-start check for work range limit system”.)

(8) Check the hydraulic components, hoses and pipes for oil leakage.

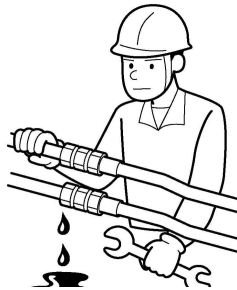

(9) Check the boom telescoping wire ropes for any damages.

- (a) No wobble or unsteady movements when telescoping the boom.
- (b) No damage at the wire rope ends.

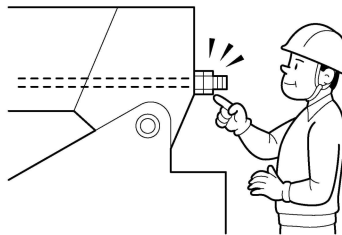

(10) Elevate the platform, then make sure that the platform does not descend naturally.

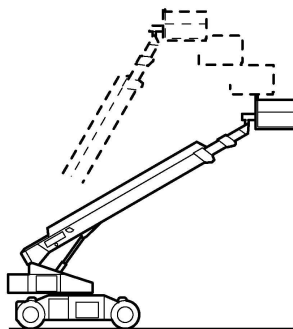

- (11) If there are no abnormalities or problems so far, step on the platform and check the following items.
- (a) Lower the boom under the horizontal, extend the boom about one meter and set the travel speed select switch to “High” and “Mid” positions. Then, make sure that the machine travels in the low speed.
 - (b) Retract the boom fully, raise the boom more than 5 degrees over the horizontal and set the travel speed select switch to “High” and “Mid” positions. Then, make sure that the machine travels in the low speed.
 - (c) Conduct the boom raising and lowering operation and make sure that the boom raising and lowering speed is slowed down corresponding to the boom extended length.
(The boom raising and lowering speed becomes slower, the further the boom is extended.)
 - (d) Conduct the boom rotating operation and make sure that the boom rotating speed is slowed down corresponding to the outreach of the platform.
(The boom rotating speed becomes slower as the platform outreach is increased.)
 - (e) Rotate the platform and make sure that the platform rotates smoothly without excessive free play.

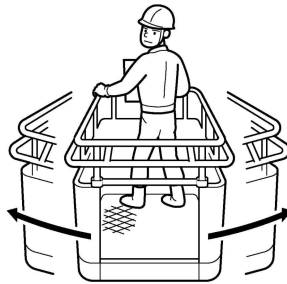





2. Pre-start checks for work range limit system

n The pre-start checks for the work range limit system are conducted as follows with the pre-start check switch held in ON position.

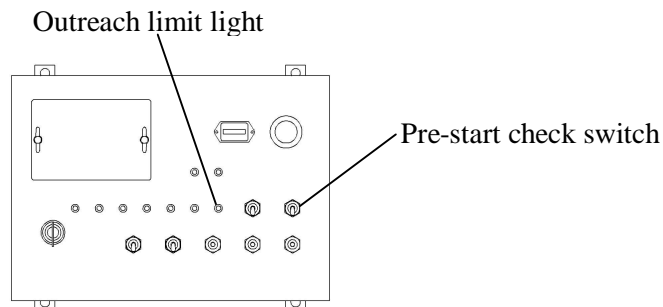
- CAUTION**
- Do not conduct the pre-start checks with the platform loaded.
 - Operate the machine from the lower control when conducting the pre-start checks.
 - If any fault is detected in the pre-start checks, stop the pre-start checks and contact Aichi service shop for inspections.

- (1) Set up the machine on firm and level surface, unload the platform, and then rotate the platform in its central position.
- (2) Turn on the engine key switch and make sure that the alarm buzzer sounds three times.
- (3) Press the emergency stop switch at the upper control, then pull the emergency stop switch and make sure that the alarm buzzer sounds three times.
- (4) Retract the boom fully, set the boom horizontally and make sure that the outreach limit light is off.



- (5) Extend the boom until the green decal  affixed on the 2nd boom section overlaps the check window  located on the 1st boom section. 

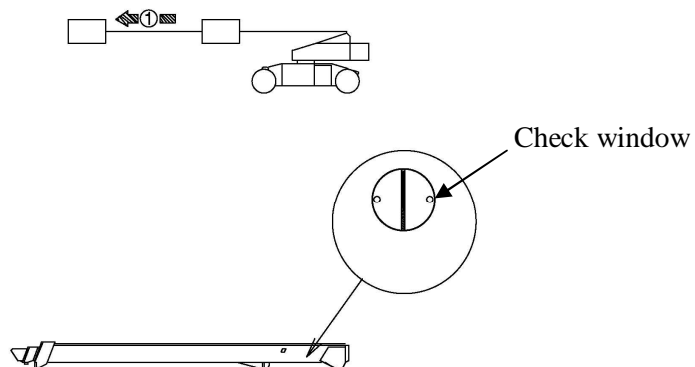

- (6) Raise the boom and set at an angle of about 30 degrees making sure that the pointer of the boom angle gauge has passed the green decal.

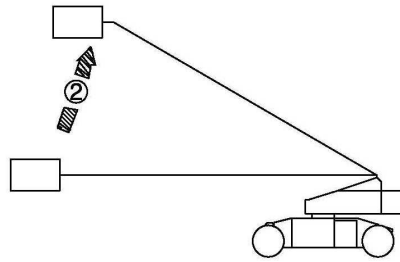

- (7) Hold the pre-start check switch in ON position, then proceed with the pre-start checks as follows.

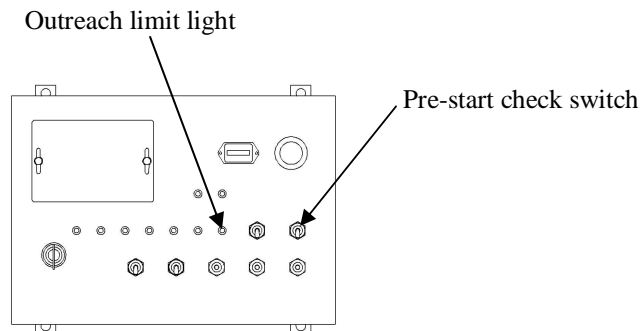

- (8) Lower the boom and make sure that the movement stops when the pointer is within the green decal zone on the boom angle gauge and the outreach limit light goes off on the lower control panel.

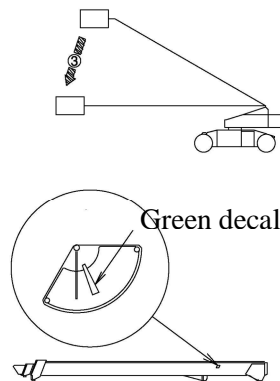

CAUTION If the pointer of the boom angle gauge goes beyond the green decal zone, stop the pre-start checks and contact Aichi service shop for inspections.

- (9) Retract the boom fully and make sure that the outreach limit light goes off.

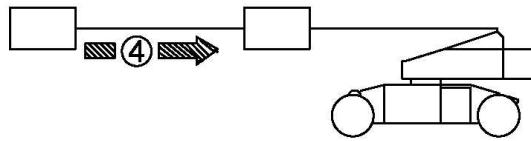

- (10) Extend the boom, and then make sure that the boom movement stops where the green decal affixed on the 2nd boom section overlaps the check window. Also, make sure that the outreach limit light goes on.

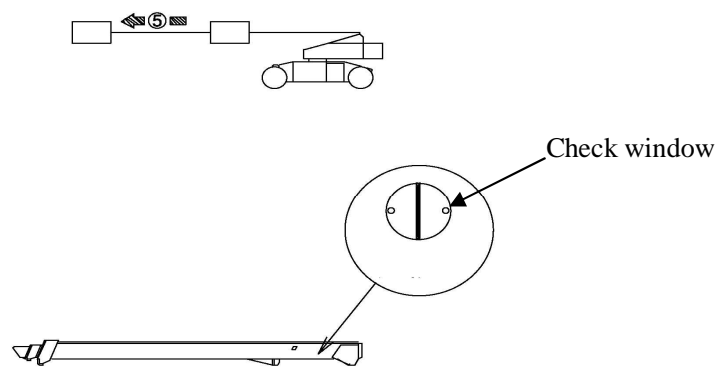

CAUTION If the boom is extended beyond the green decal, stop the pre-start checks and contact Aichi service shop for inspections.

- (11) Raise the boom fully and make sure that the outreach limit light goes off.

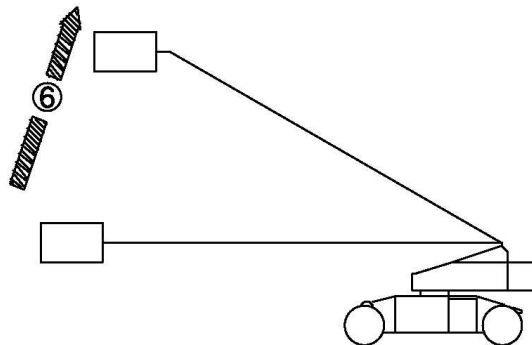

- (12) Release the pre-start check switch. The pre-start checks for the work range limit system are now completed.

- CAUTION** • If the work range limit system is normal, the boom movement stops automatically when the outreach of the platform reaches the specified value. The engine stops automatically to prevent the machine from tipping over, if the boom movement continued beyond the specified outreach during the pre-start checks. In this case, restart the engine with the engine key switch and return the boom in the stowage position. Then, contact Aichi service shop for inspections.
- If the pre-start check switch is turned on while the platform is positioned out of the specified outreach, the engine stops automatically. This is not a failure.

VI For Safety

1. Before operation

- n Only trained and authorized personnel are permitted to operate this machine.

DANGER Untrained or unauthorized personnel must not operate this machine.

- n Always wear safety gears e.g. helmet, safety shoes and safety harness. The authorized safety harness should be used.

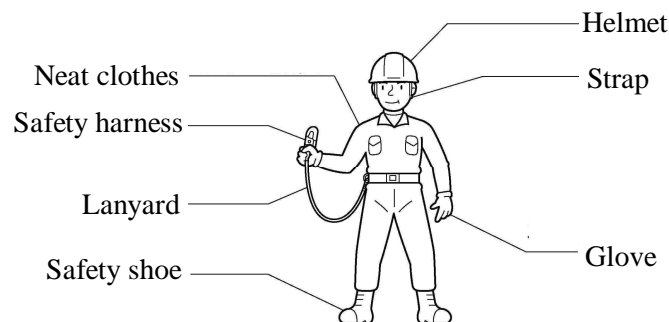

- n Nominate a supervisor and conduct operation according to his/her instructions.

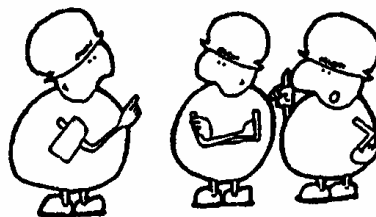

- n This machine is not allowed to travel on public highways.
- n Observe the rules such as prohibited items and working procedures for safe operation.

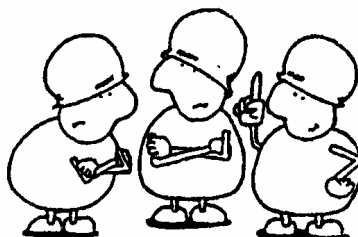

n Observe all of the national or local laws and regulations



n Keep combustibles (fuel and oil) away from smoke or fire.



n Check that there are no inflammable substances under or around the machine.

n Do not operate the machine when you are intoxicated or fatigued.

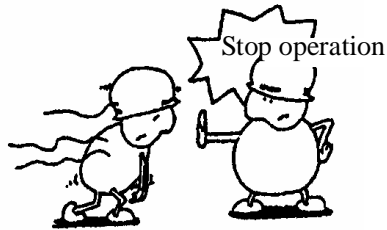

n Stop operation in bad weather.

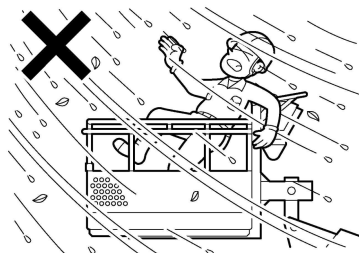

ADVICE Criteria of a bad weather

- Strong wind Average wind velocity over ten-minute period is over 12.5 m/sec (28 MPH).
- Heavy rain Rainfall of 50 mm (2.0 inches) or more
- Heavy snow Settled snow of 25 cm (9.8 inches) or more
- Thunder/Lightening

Even in conditions below the criteria above, obey the instructions of your supervisor.

- n The criteria of wind velocity at 10 m (33 feet) above ground are as follows:

Wind velocity at 10 m (33 feet) above ground	Situation on the ground
5.5 ~ 8.0 m/sec (12.3 ~ 17.9 MPH)	Dust rises and paper flies. Twigs move.
8.0 ~ 10.8 m/sec (17.9 ~ 24.2 MPH)	Heavily-leaf trees sway and waves cresting in ponds or lakes can be seen.
10.8 ~ 13.9 m/sec (24.2 ~ 31.1 MPH)	Large trees sway. Overhead power lines hum. Umbrellas are difficult to use.
13.9 ~ 17.2 m/sec (31.1 ~ 38.5 MPH)	Whole trees swing. Walking against the wind is difficult.

- Generally, the higher we go, the higher the wind velocity is. Therefore, when the platform is elevated, be careful so that the wind velocity at the platform does not exceed 12.5 m/sec (28 MPH).

- n Do not perform operation on a slippery or icy surface. If it is unavoidable, be sure to use a nonskid gear such as tire chains.
- n Do not modify the machine without obtaining the manufacturer's approval.

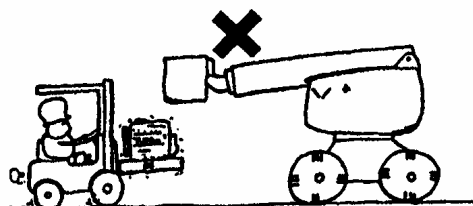

ADVICE Do not add anything to the machine, which could increase the wind load, e.g. “Notice boards” on the platform.

- n Do not wash the sections where the wash prohibition decals are affixed. Particularly, do not use pressurized water.

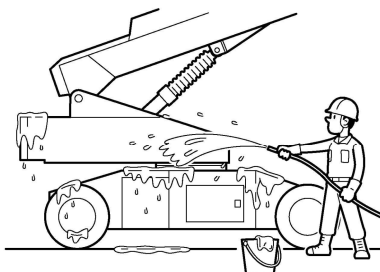

ADVICE Wipe off dirt from electrical components using dry cloths.

- n Do not conduct operation while standing on the turntable or chassis.

2. During operation

- n After starting the engine, warm up the machine without loading the engine.

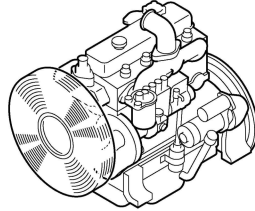

- n Do not use the machine near electric power lines.

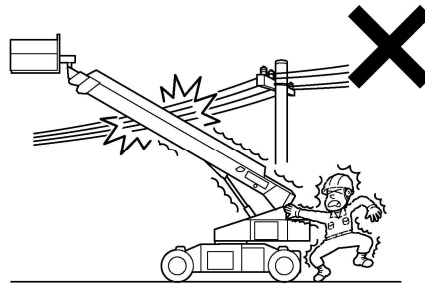

- DANGER**
- This machine is not electrically insulated, so do not approach or contact electrical conductors.
 - Keep a safe distance from electric power lines and apparatus. Failure to do so may result in serious injury or death.
 - For safe distance, check the national or local regulations. If no national or local regulation is available, use the table below.

Voltage range (Phase to Phase)	Minimum safe approach distance
0 to 300 V	Avoid contact
Over 300V to 50 KV	3.05 meters (10 feet)
Over 50 KV to 200 KV	4.60 meters (15 feet)
Over 200 KV to 350 KV	6.10 meters (20 feet)
Over 350 KV to 500 KV	7.62 meters (25 feet)
Over 500 KV to 750 KV	10.67 meters (35 feet)
Over 750 KV to 1,000 KV	13.72 meters (45 feet)

- n Do not conduct both the traveling and the boom operations simultaneously.

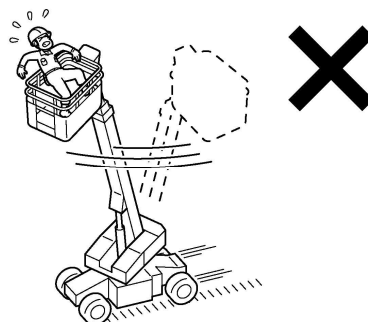

- n Before traveling, make sure the traveling direction of the machine by checking the arrow decals affixed on the chassis.

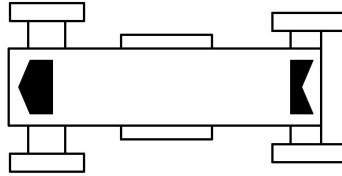

- ADVICE** * The arrow indicates the "Forward" direction.
- * Before traveling, check the surroundings and make sure that no person or obstacle is in the traveling direction.
 - If your vision is poor, have a guide to assist you.

- n Do not elevate the platform on soft or uneven surface.

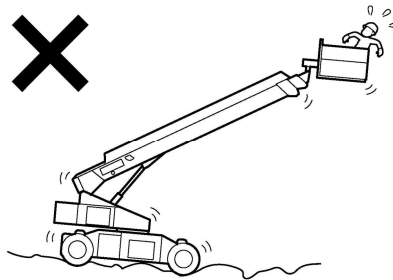

DANGER The machine may tip over on soft or uneven ground.

ADVICE The maximum ground contact pressure of the machine is:

SP18AJ / ISP60J -----	6.0 kg/cm ²	(85 PSI)
SP21AJ / ISP70J -----	7.0 kg/cm ²	(100 PSI)

- n Do not elevate the platform on a slope.

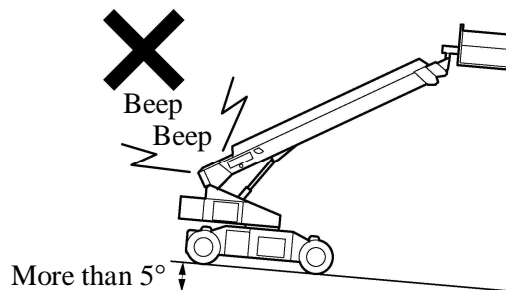

DANGER When the machine tilts more than 5 degrees, the tilt alarm buzzer sounds and the tilt warning light goes on. Do not elevate the platform, if the tilt alarm buzzer sounds.

- n When you are obliged to travel on the slope of more than 5 degrees for the purpose of transportation, be sure to fully retract the boom and lower the boom under the horizontal.

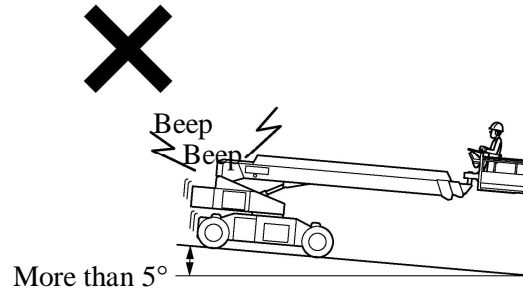

RETRACT BOOM AND LOWER UNDER THE HORIZONTAL.

- n Be sure to wear a safety harness and fasten its lanyard to the specified anchor point on the platform. Only authorized safety harness should be used.

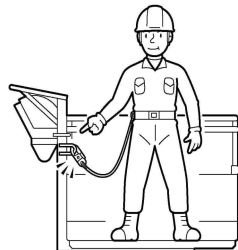

- n Do not bind the sliding guardrail at the entrance of the platform.

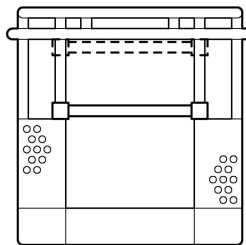

- n Check the surroundings carefully before starting operation.



- CAUTION**
- Make sure that no person or obstacle is around the turntable before rotating the boom.
 - Take care that your hands on the handrail are not caught in other obstacles.

- n The turntable protrudes 1.15 metres (3 ft – 9 in) beyond the width of the machine when rotating the boom, so watch the turntable movement and make sure no person or obstacle is around the turntable. If the boom cannot be raised and the rear of the turntable cannot be seen, have a guide assist you.

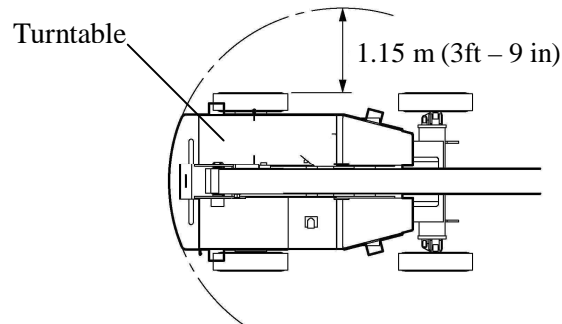

- n Do not operate the machine roughly.



ADVICE When you reverse the operating direction, bring the machine to a standstill, then operate the control lever or switch to the opposite direction.

- n If malfunction occurs in the platform leveling system, stop using the machine and contact Aichi service shop for inspections.
- n Do not reach out of the platform.

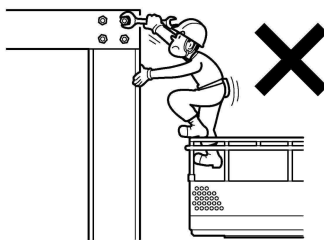

DANGER

- Always keep your feet firmly on the platform floor and conduct operation with stable posture.
- Do not step on the handrail.

n Do not use a ladder or step in the platform.

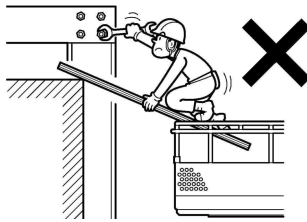

n To prevent incorrect operation of the control levers and switches, the control panel should be lighted up in the dark.

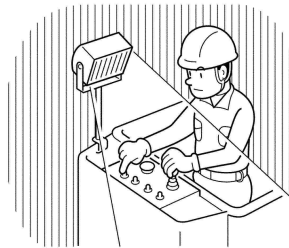

n Do not leave or enter the platform while the platform is elevated.

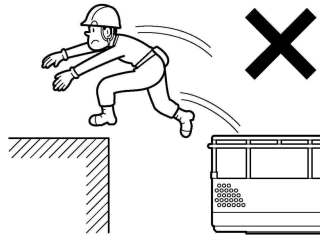

n Do not drop anything from the platform.

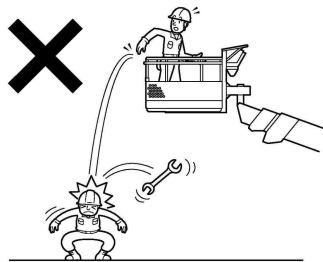

n Do not allow any person to get under the boom and the platform.

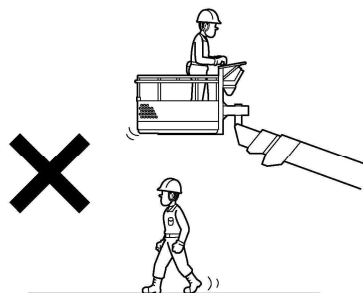

- n No smoke or fire on the platform.

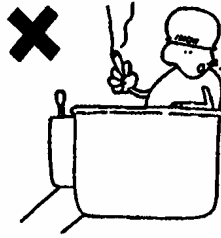

CAUTION Do not put any inflammables in the platform.

- n When gas cutting or arc welding is conducted on the platform, take necessary measures, for example; cover the machine with fireproof sheet so that no sparks or fragments hit the machine, especially the hydraulic hoses and batteries.

DANGER If sparks enter the machine, it may cause a fire.

- n If the counterweight hits an obstacle, the counterweight-mounting unit may be damaged. In this case, contact Aichi service shop for inspections.

DANGER If the counterweight-mounting unit is damaged, the counterweight may be detached during traveling or transport, resulting in serious injury or death.

- n Never use the machine with the counterweight detached. The machine will tip over and resulting in serious injury or death.

- n Never conduct the following operations, which may cause the machine to tip over or be damaged, resulting in serious injury or death.

- (a) Do not push or pull any objects by operating the machine.

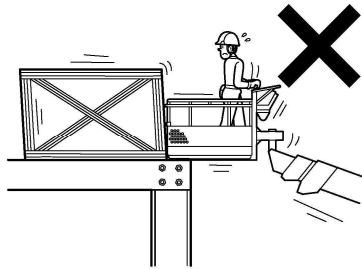

- (b) Do not hoist any objects with a hook or a rope fixed to the boom and the platform.

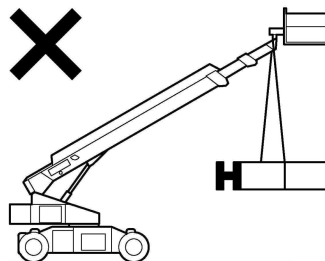

- (c) Do not overload the platform. The specific working load is marked on the platform.

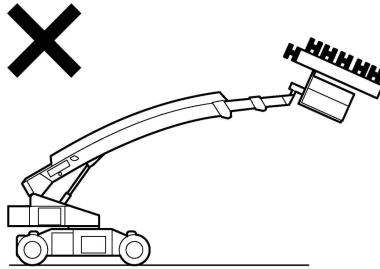

DANGER Do not load any area other than the platform.

- n Do not conduct the followings that may damage the platform leveling system
 - (a) Do not press the platform against any overhead structures by elevating the platform.

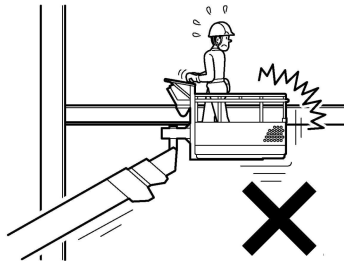

- (b) Do not hit or push any structures or objects by traveling.

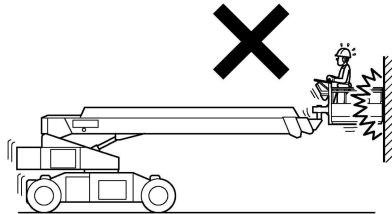

DANGER If either of the above operations has been conducted, stop using the machine and contact Aichi service shop for inspections. If not, the platform may tilt excessively resulting in serious injury or death.

- n When non-marking white tires are used on a plastic floor, static electricity may collect on the machine. Use an earth chain or strap to remove the static electricity from the machine.

n If the boom is left extended or raised while the hydraulic oil temperature is high, the boom may be retracted or lowered somewhat. This is caused by the contraction of the hydraulic oil confined in the hydraulic cylinders due to a change in the hydraulic oil temperature.

ADVICE • If the hydraulic oil temperature drops 10°C with the boom fully extended and raised, the boom will retract approx. 30 mm (1.2 inches). This value, however, varies depending on the boom length and the boom angle.

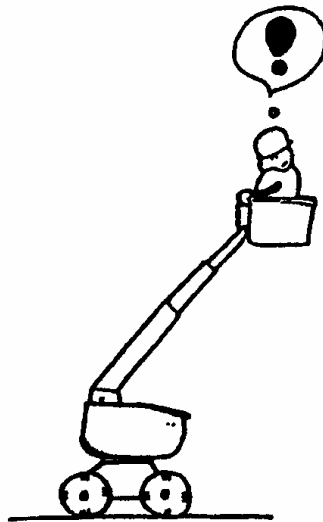

3. After operation

- n Take all tools and materials from the platform.

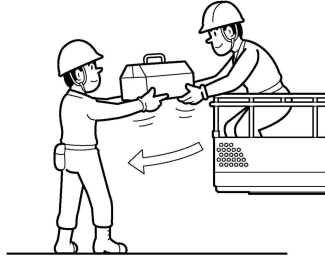

- n Retract and lower the boom fully.
- n Stop the engine by turning off the engine key switch.

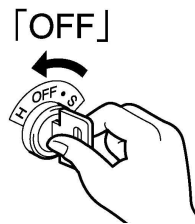

CAUTION Remove the key to prevent any possible danger caused by unauthorized use.

- n If the machine is used for sand blasting operations, remove the sand from the machine as follows using the compressed air.

- (1) Use the air nozzle A and remove the sand lying on the machine.

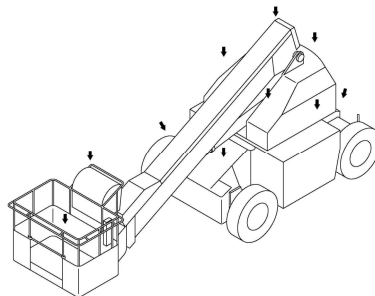

Air nozzle **A** 

Air nozzle **B** 

Air nozzle **C** 

(2) Remove the sand lying in the boom as follows.

- 1) Extend the boom about 150 mm (6 inches), and then remove the sweepers installed on the top ends of the 1st and 2nd boom sections.
- 2) Remove the cover installed on the tail end of the 1st boom section and the covers installed on the upper surface of the 1st boom section.
- 3) Set the boom to the negative angle, and then blow air from the tail openings of each boom section using the air nozzle A.
- 4) Set the boom to the positive angle, insert the nozzle B in the 3rd boom section and remove the sand lying in the 3rd boom section by blowing air. The sand will fall off through the boom tail openings.

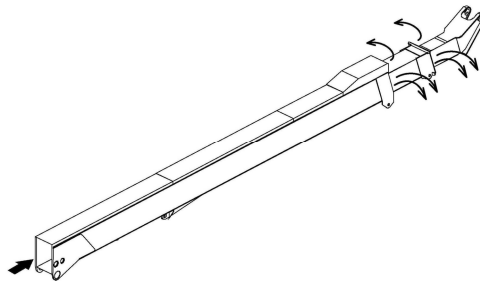

- 5) Insert the air nozzle C behind the hose sheave and remove the sand lying on the sheave by blowing air

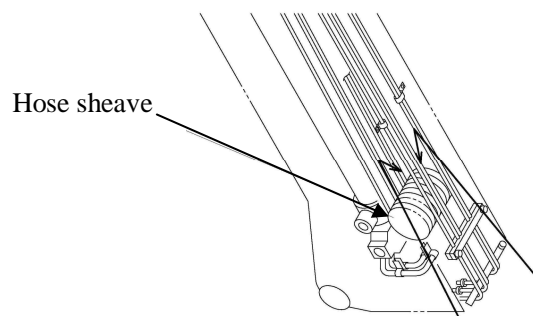

- (3) Blow air and remove the sand from any other part of the machine.

ADVICE After the sand blasting operation, make sure to clean the air filter and remove the sand lying on the engine.

VII Machine setting up

(1) Always set up the machine on firm and level surface before elevating the platform.

DANGER Do not elevate the platform on soft or uneven surface as the machine may tip over, resulting in serious injury or death.

ADVICE The maximum ground contact pressure of the machine is:
SP18AJ / ISP60J ----- 7.0 kg/cm² (100 PSI)
SP21AJ / ISP70J ----- 8.0 kg/cm² (114 PSI)

(2) Park the machine near the working target.

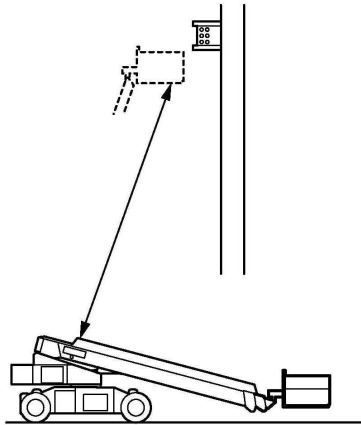

(3) Do not obstruct the transit of other vehicles and passersby, and also do not permit any unauthorized person to enter the working area.

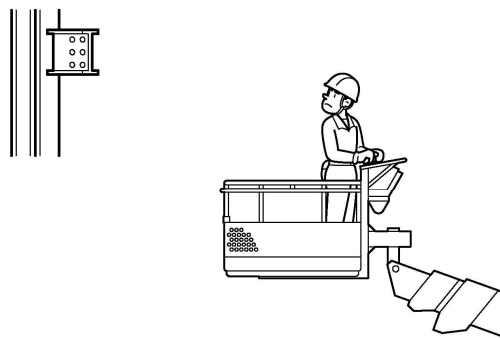

CAUTION Place warning signs, indicate detours and install crash-prevention guards.

VIII Safety Devices

The safety devices ensure safety and prevent damage to the machine.

Name	Main function
Relief valves	Protect the hydraulic components by relieving abnormally high pressure in the hydraulic system.
Boom elevation safety device (Holding valve)	Prevents the natural descent of the boom when the hydraulic hose is broken.
Boom telescoping safety device (Holding valve)	Prevents the boom from natural retraction or extension when the hydraulic hose is broken.
Platform leveling safety device (Holding valve)	Maintains the platform level when the hydraulic hose is broken.
Fly jib safety device (Holding valve)	Prevents the natural descent of the fly jib when the hydraulic hose is broken.
Foot switch	The boom, fly jib, traveling and platform rotating functions are disabled unless the foot switch is pressed.
Motion alarm buzzer	The motion alarm buzzer sounds when the machine is in motion to warn the people nearby.
Emergency stop switch	Stops all of the movements of the machine when this switch is pressed.
Tilt alarm buzzer	The tilt alarm buzzer sounds, if the machine tilts more than 5 degrees.
Travel speed limit system	The high and mid speed traveling is disabled, unless the boom is retracted and is lowered under the horizontal.
Rotation lock pin	Fixes the turntable to the chassis to prevent the turntable from being rotated when transporting the machine.
Emergency pump	Auxiliary hydraulic pump driven by the battery. And used to lower the platform in the event of engine or main pump failure.
Alarm horn	Before moving the machine, sound the alarm horn to warn the personnel around the machine.
Rotating speed limit system	This system automatically reduces the boom rotation speed to ensure the safe speed as the outreach of the platform increases.
Elevating speed limit system	This system automatically reduces the boom rising and lowering speed to ensure the safe speed as the boom extends.
Traveling speed limit system	This system automatically reduces the traveling speed to ensure the safe speed as the boom extends.
Work range limit system	This system automatically limits the work range (Outreach) of the platform within the specific range.
Boom wire rope failure detecting system	This system disables the boom extending functions in the event of the wire rope failure.
Overload sensing system	This system disables all of the functions when the platform is overloaded.
Boom / Travel function interlock system (For CE specification only)	This system stops all of the functions when the travel operation and the boom or fly jib operations are conducted simultaneously.

IX Control panels

1. Lower control panel

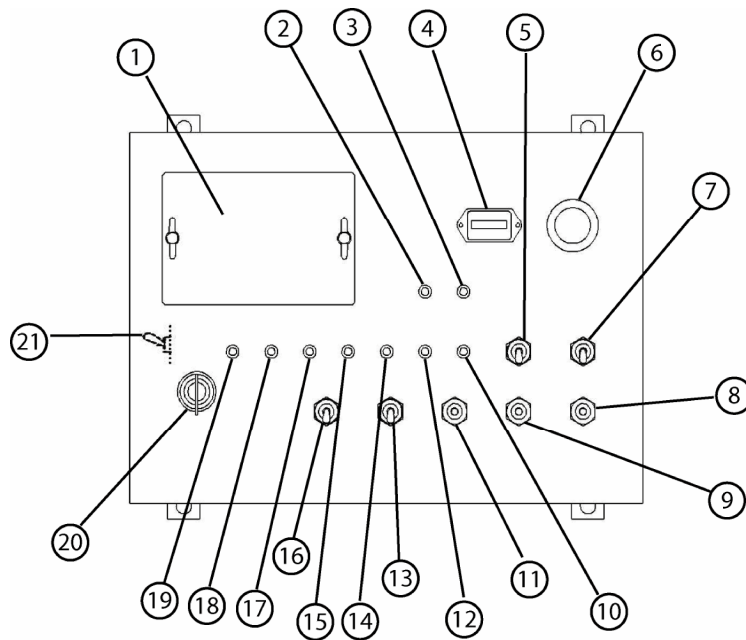





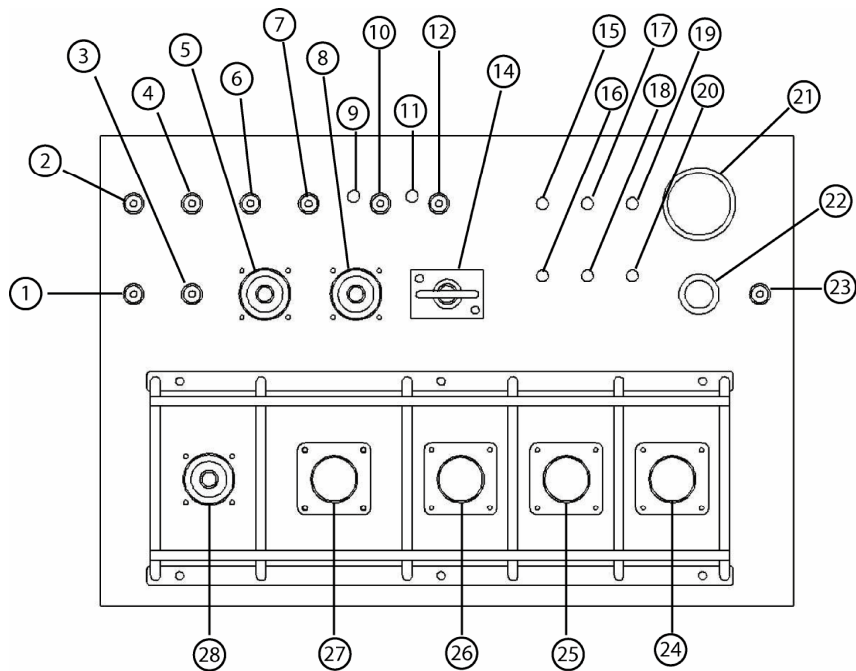















No.	Name
1	Fuse holder
2	System failure light
3	Overload sensing light
4	Hour meter
5	Emergency pump switch
6	Emergency stop switch
7	Pre-start check switch
8	Boom elevation switch
9	Boom telescope switch
10	Outreach limit light (Equipped only on SP21A / ISP70)
11	Boom rotation switch
12	Air filter clog light
13	Charge light
14	Water temperature light
15	Dead-man switch
16	Engine oil pressure light
17	Fuel level light
18	Pre-heat light (This light is not equipped on the machine with the Duel fuel engine)
19	Engine key switch
20	Limit cancel switch



2. Upper control panel

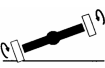

No.	Name	No.	Name
1	Travel speed select switch	14	System failure light
2	Emergency pump switch	15	Overload light
3	Plug for optional switch	16	Fuel level light
4	Plug for optional work light switch	17	Outreach limit light (Equipped only on SP21A / ISP70)
5	Platform rotation switch	18	Engine failure light
6	Plug for optional head light switch	19	Tilt light
7	Fuel select switch (for Dual fuel engine only)	20	Emergency stop switch
8	Hydraulic generator light (Option for USA)	21	Horn switch
9	Hydraulic generator switch (Option for USA)	22	Engine start switch
10	Horizontal / Vertical light	23	Travel control lever
11	Horizontal / Vertical select switch	24	Boom elevation control lever
12	Platform level adjust switch	25	Boom telescope control lever
13	-----	26	Boom rotation control lever
		27	Steering switch

3. Pictorial symbols

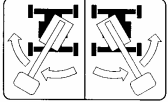
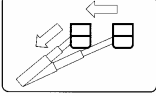
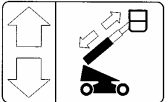
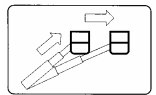
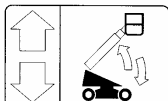
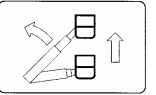
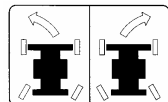
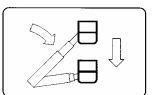
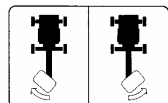
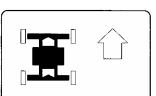
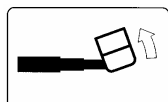
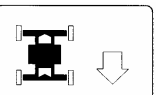
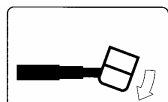
	OFF		Engine failure indicator
	Lower control		Horizontal / vertical movements
	Pre-heat		Tilt warning indicator
	Engine start		Platform contact release
	Upper control		Engine start
	Pre-heat indicator		Emergency pump
	Fuel level indicator		Pre-start check
	Oil pressure indicator		High speed
	Water temperature indicator		Low speed
	Charge indicator		High speed traveling
	Outreach limit indicator		Differential lock

	Boom rotation		Telescope / Horizontal (IN)
	Boom telescope		Telescope / Horizontal (OUT)
	Boom elevation		Elevation / Vertical (UP)
	Steering		Elevation / Vertical (DOWN)
	Platform rotation		Traveling (FWD)
	Platform level adjust (UP)		Traveling (REV)
	Platform level adjust (DOWN)		Horn

X Operating Method

1. Engine start operation

1.1 Engine start operation from Lower control

Start the engine from the lower control as follows.

- (1) Turn the engine key switch on the lower control panel to LOWER control position. Then, make sure that both of the oil pressure and charge lights go on.

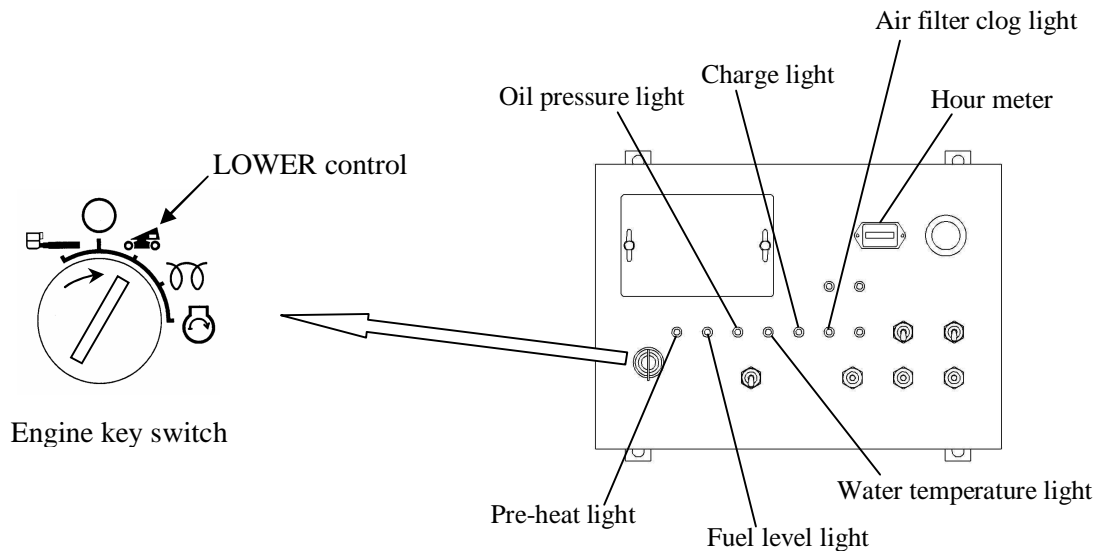

(a) Charge light

After starting the engine, the charge light goes off. If the light goes on whilst the engine is in motion, it is because of a charging system failure.

CAUTION If this light goes on whilst the engine is in motion, check the charging system, e.g. alternator and fan belt.

(b) Oil pressure light

After starting the engine, the oil pressure light goes off. If the light goes on whilst the engine is in motion, it is because of an engine lubrication system failure.

CAUTION If this light goes on whilst the engine is in motion, check the engine lubrication system, e.g. shortage or leakage of engine oil or oil filter clogging.

(c) Air filter clog light

This light goes on when the air filter is clogged. Clean or replace the air filter element, if this light goes on while the engine is in motion.

(d) Water temperature light

When the engine cooling water temperature goes up abnormally, the engine stops and this light goes on to protect the engine from overheat. This light stays off when the engine key switch is just turned to the “LOWER” control position.

CAUTION • If this light goes on during operations, stop using the machine and check the engine cooling system, e.g. shortage of cooling water and broken fan belt.

DANGER • When the engine is overheated, do not remove the radiator cap, as the heated water will splash out, resulting in scald.

(e) Fuel level light

This light goes on when the fuel level is low. Refill the fuel, if this light goes on.

(f) Hour meter

The hour meter works only when the engine is in motion.

(2) Push in the key and turn the engine key switch to START position to start the engine.

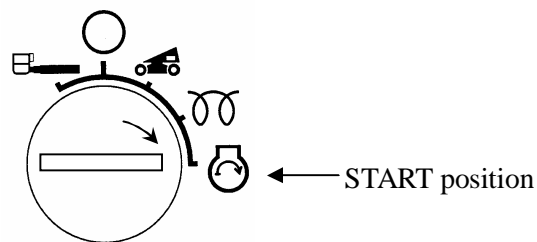

CAUTION • After starting the engine, immediately release the engine key switch from the START position. Do not hold the key switch in the START position for more than 10 seconds, as this may cause damage to the starter motor.

(3) If the engine is cold and difficult to start, turn the engine key switch to PREHEAT position and hold there till the preheat light goes off.

Note: The preheat light is not equipped on the machine with the duel fuel engine. It is not necessary to preheat before starting the duel fuel engine.

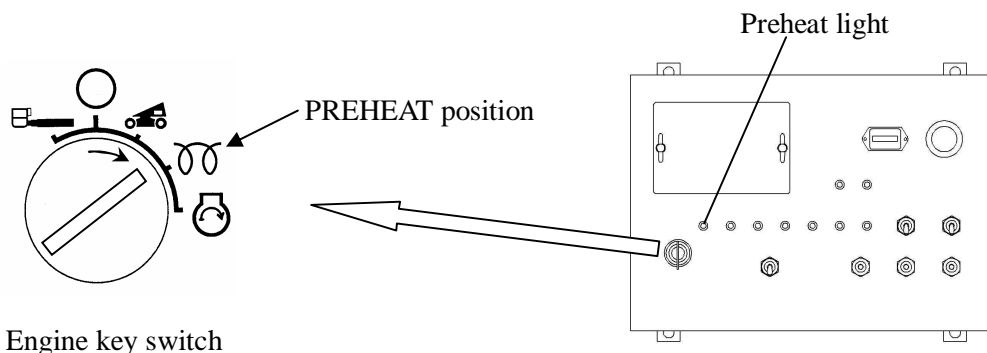

ADVICE The preheat light goes on when the engine key switch is turned to LOWER control or PREHEAT position and the light goes off when the preheating is completed.

- (4) After starting the engine, idle the engine for about five minutes for warming up.

CAUTION If ambient temperature is lower than the allowable range of the hydraulic oil temperature, warm up the machine to raise the hydraulic oil temperature, then operate the machine.

1.2 Engine start operation from Upper control

- (1) Turn the engine key switch to UPPER control position.

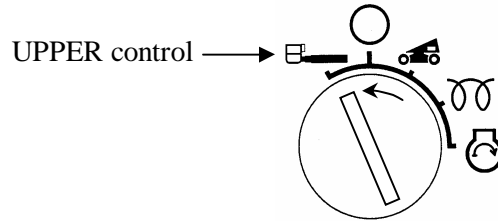

- (2) Step on the platform, and then operate the engine start switch without pressing the foot switch to start the engine.

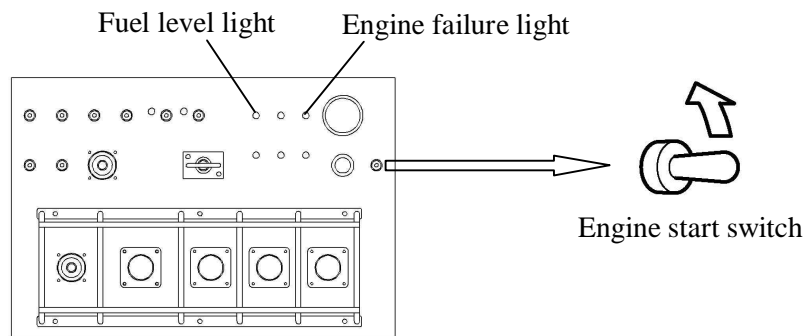

ADVICE * Engine failure light

This light goes on when the engine key switch is set to UPPER control position and then goes off as soon as the engine starts.

* Fuel level light

This light goes on when the fuel level is low. Refill the fuel, if this light goes on.

CAUTION If the engine failure light goes on whilst the engine is in motion, it is because of an engine failure, so stop using the machine and check the engine. To identify the engine failure, check the charge, oil pressure, water temperature and air filter clog lights on the lower control panel.

2. Engine stop operation

To stop the engine from the lower control, either press the emergency stop switch or turn the engine key switch to OFF position.

When stopping the engine from the platform, press the emergency stop switch.

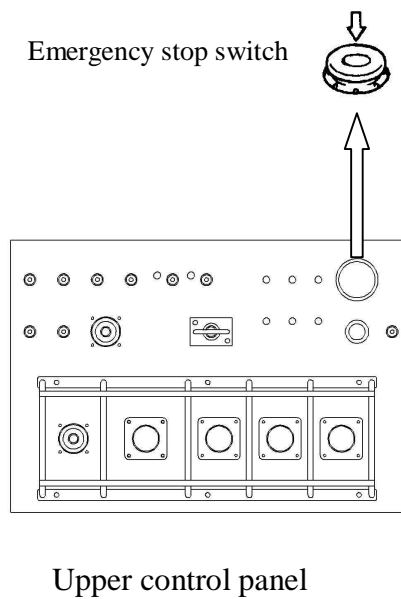
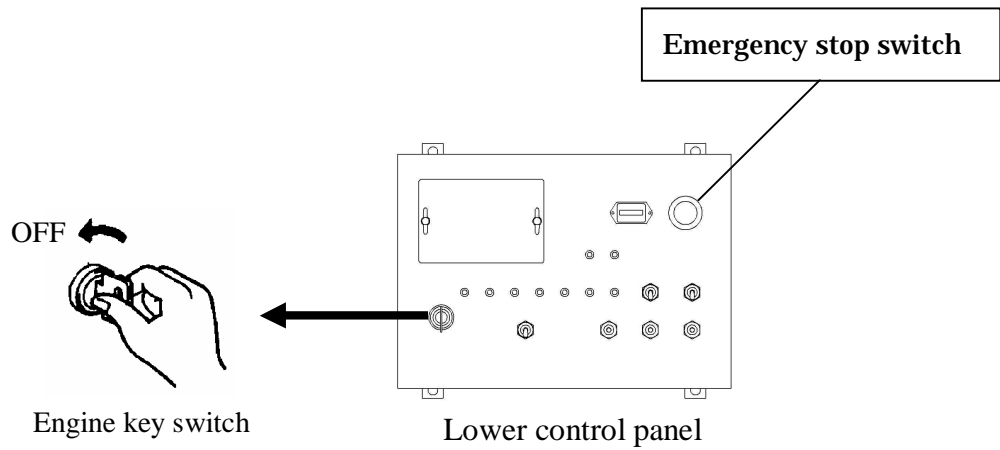

3. Lower control (Operation from ground)

Be sure to set the engine key switch in LOWER control position to operate the machine from the lower control.

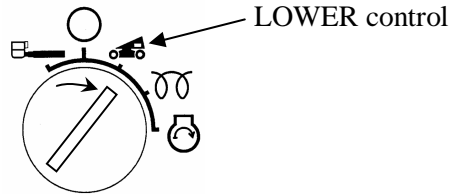

3.1 Boom operation

Hold the dead-man switch in its ON position and operate each boom function switch.

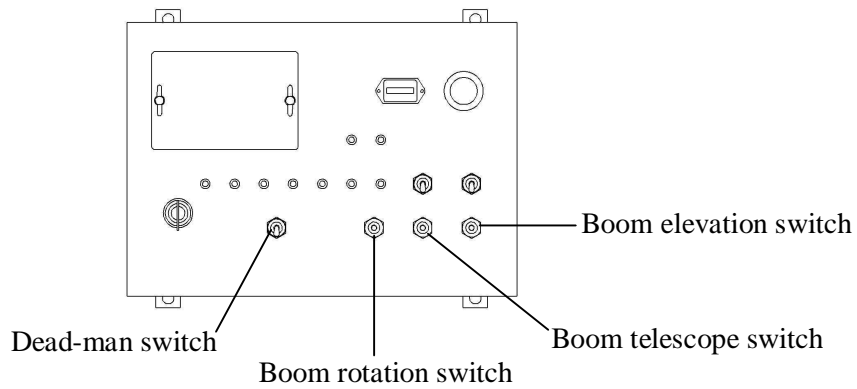

3.1.1 Boom raising and lowering operation

Hold the dead-man switch in its ON position and operate the boom elevation switch to raise or lower the boom.

Boom up		
Stop		
Boom down		

CAUTION Do not press the boom and the platform against ground by lowering the boom.

3.1.2 Boom rotating operation

Hold the dead-man switch in its ON position and operate the boom rotation switch to rotate the boom.

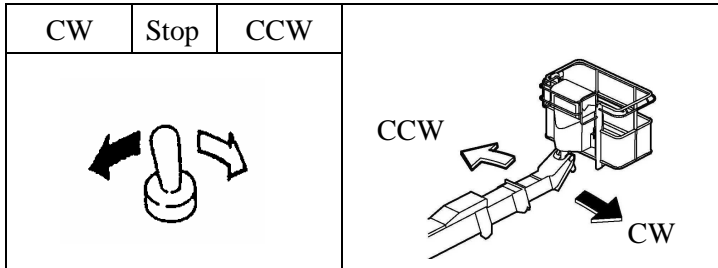

DANGER Before rotating the boom, check that no obstacle interferes with the turntable.

CAUTION The boom may not be rotated smoothly when the machine is tilted.

3.1.3 Boom telescoping operation

Hold the dead-man switch in its ON position and operate the boom telescope switch to extend or retract the boom.

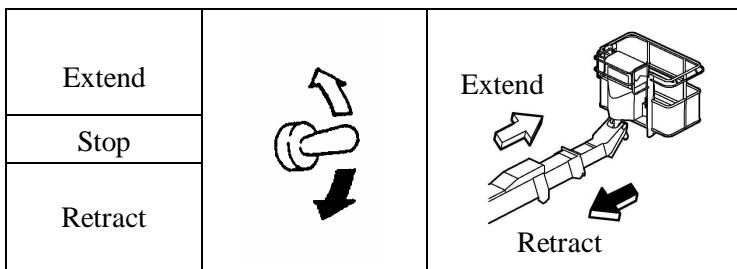

3.1.4 Fly jib operation

Hold the dead-man switch in its ON position and operate the fly jib switch to raise or lower the fly jib.

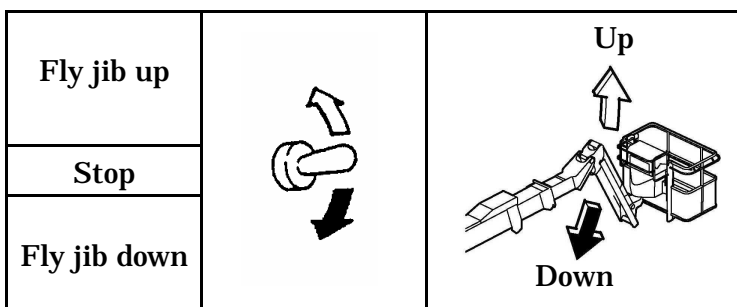

3.2 Emergency stop operation

Use the emergency stop switch. When the emergency stop switch is pressed, the engine stops and all of the functions are disabled. Press the emergency stop switch in the following cases:

- (1) To stop the engine.
- (2) When the personnel on the ground judges that the operation from the upper control is unsafe.
- (3) When the machine is uncontrollable due to malfunction.

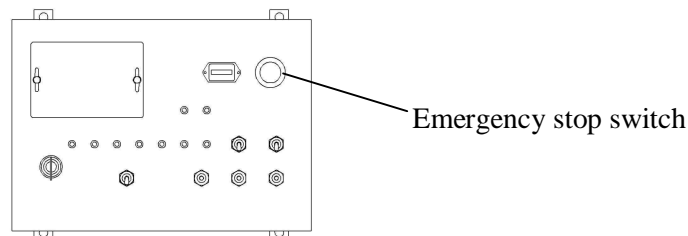

ADVICE To resume operation, pull the emergency stop switch.

- CAUTION**
- If the boom descends gradually after the emergency stop switch is pressed, this may be a natural descent of the hydraulic cylinder. In this case, restart the engine with the engine key switch and operate the boom to prevent the boom and the platform from coming into contact with any obstacles. Then, lower the platform to the ground and stop using the machine.
 - If the emergency stop operation was used as a result of malfunctions, stop using the machine immediately and contact Aichi service shop for inspections.

3.3 Emergency pump operation

If the machine does not work due to engine or main pump failure, use the emergency pump to lower the platform. It is not necessary to turning on the dead-man switch when operating the boom from the lower control with using the emergency pump.

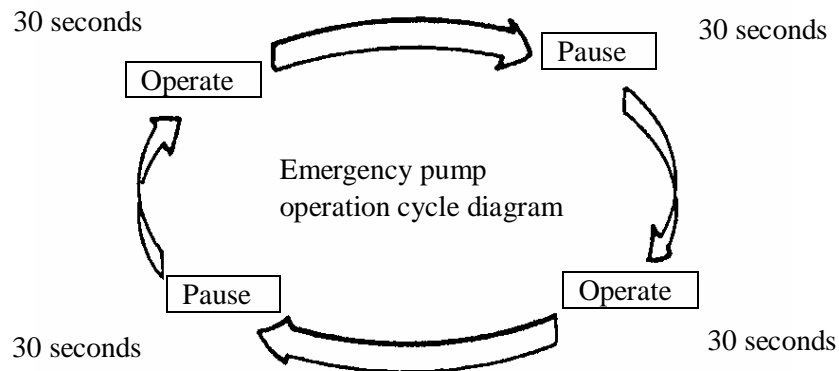
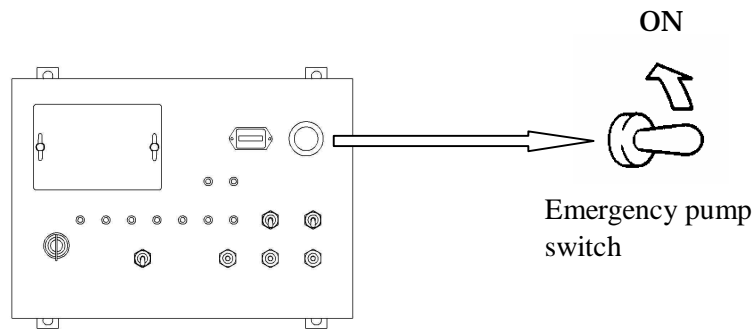

- CAUTION**
- Operate the emergency pump every other 30 seconds. The continuous operation in excess of 30 seconds may cause the damaged emergency pump.
 - Do not impose heavy load to the emergency pump, e.g. by attempting traveling operations.

ADVICE If the emergency stop switch has been pressed at the upper control with no operator on the platform, the platform can be lowered by operating both of the emergency pump switch and the boom control switches simultaneously from the lower control.

3.4 Platform level adjustment

If the platform is out of level, adjust as follows:

- (1) Set up the machine on firm level surface and move the boom to the suitable position to adjust the platform level.

Danger Do not allow any person or object on the platform when adjusting the platform level.

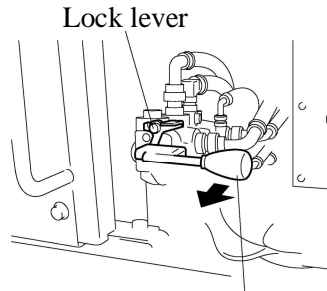

- (2) Pull the platform level adjust lever while pushing down the lock lever located beside the lower control box.



- (3) Operate the boom telescope switch to adjust the platform level.

To tilt the platform forward, operate the boom telescope switch to “OUT”.

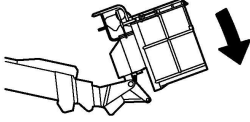
To tilt the platform backward, operate the boom telescope switch to “IN”.

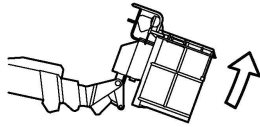
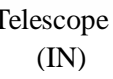
To tilt forward		Telescope (OUT) 
To tilt backward		Telescope (IN) 

- (4) After adjusting the platform level, return the platform level adjust lever to its original position and also check that the lock lever is up.

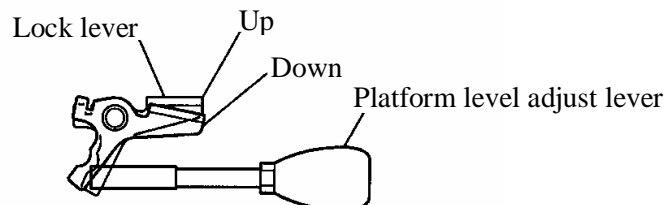

- (5) Repeat the boom raising, lowering and telescoping operations several times and make sure that the platform stays level.

ADVICE If the boom is retracted fully, the tilting speed of the platform may be slow. To increase the speed, return the platform level adjust lever to its original position and extend the boom about one meter (3ft – 3in), then adjust the platform level as stated above.

3.5 Bleeding air from the platform leveling system

If the platform does not stay level after adjustment, air may have entered the platform leveling system. In this case, bleed air in the following manner.

- (1) Set up the machine on firm and level surface, set the boom horizontally, and then extend the boom about 1 meter (3ft – 3 in).

DANGER Do not allow any person or object on the platform when bleeding air.

- (2) Pull the platform level adjust lever while pushing down the lock lever located beside the lower control box.

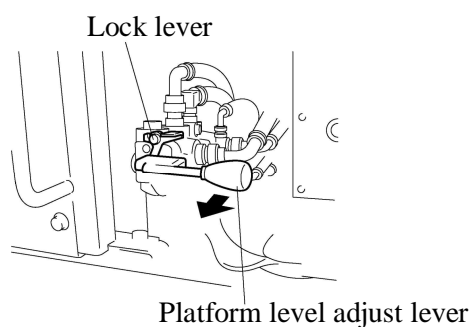

- (3) Hold the dead-man switch in its ON position and operate the boom telescope switch to fully tilt the platform forward and backward several times.

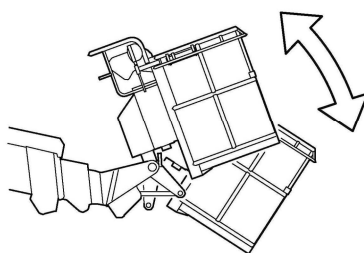

- (4) After adjusting the platform level, return the platform level adjust lever to its original position and also check that the lock lever is up.
- (5) Repeat the boom raising, lowering and telescoping operations several times and make sure that the platform stays level.

3.6 Indicator lights

The following indicator lights are equipped on the lower control panel.

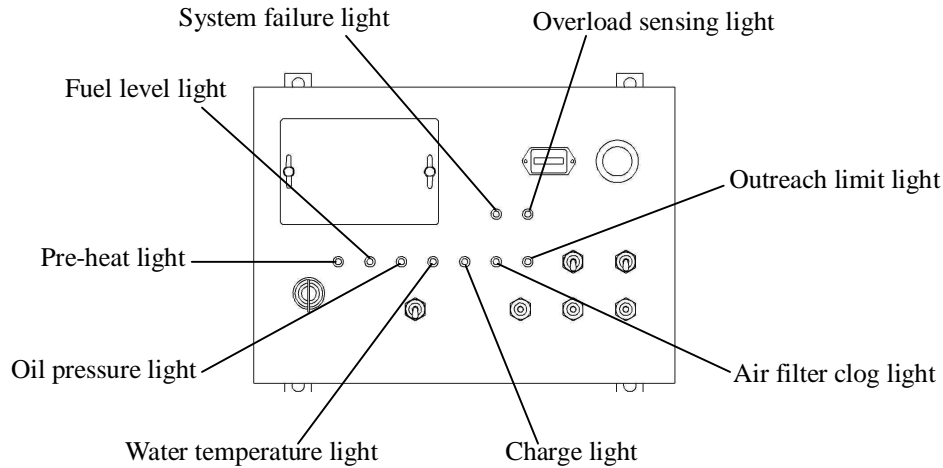

(1) System failure light

This light blinks, in the event of a computer control system failure.

Caution: Stop using the machine and contact Aichi service shop for inspections, if this light blinks. This light also blinks when the machine tilts excessively, but this is not a failure.

(2) Overload sensing light

When the platform is overloaded, this light blinks, the alarm buzzer sounds and all of the functions are disabled.

(3) Pre-heat light (equipped only on the machine with diesel engine.)

This light goes on when the engine key switch is turned to the LOWER control or PRE-HEAT position and goes off when the preheating is completed.

(4) Fuel level light

This light goes on when the fuel level is low. Refill with fuel, if this light goes on.

(5) Oil pressure light

After starting the engine, this light goes off. Check the engine lubrication system, e.g. shortage of engine oil, if this light goes on while the engine is in motion.

(6) Water temperature light

When the engine cooling water temperature rises abnormally, the engine stops and this light goes on to protect the engine from overheat. Check the engine cooling system, if this light goes on.

(7) Charge light

After starting the engine this light goes off, check the charging system, e.g. alternator and fan belt, if this light goes on while the engine is in motion.

(8) Air filter clog light

This light goes on when the air filter is clogged. Clean or replace the air filter element, if this light goes on while the engine is in motion.

(9) Outreach limit light (equipped only on SP21A / ISP70.)

This light goes on when the work range limit system limits the outreach of the platform by disabling the boom extending and lowering functions.

Caution: This light blinks when there is a failure in the work range limit system. Stop using the machine and contact Aichi service shop for inspections, if this light blinks.

3.7 Limit cancel switch operation

CAUTION Do not use this limit cancel switch except for emergency.

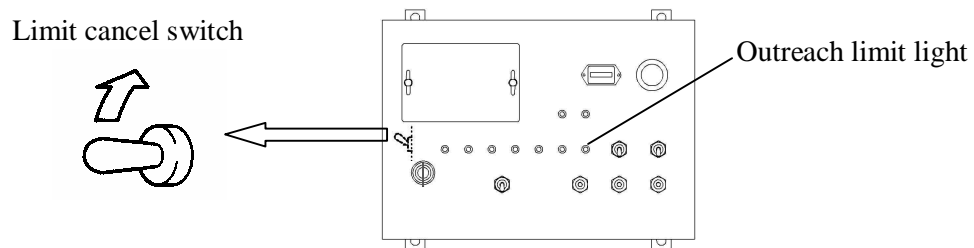

If the machine does not work due to malfunctions, lower the platform to ground using this limit cancel switch as follows.

- (1) Turn on the limit cancel switch and hold the switch in its ON position. The alarm buzzer sounds when this switch is turned on.
- (2) Retract the boom fully by operating the boom telescope switch.
- (3) Lower the boom by operating the boom elevation switch.

DANGER

- Neither the working range limit system nor the overload sensing system work, if this limit cancel switch is operated. Therefore, do not extend the outreach of the platform when lowering the platform using this limit cancel switch.

CAUTION

- This limit cancel switch should only be used when the working range limit system is out of order or when the overload sensing system detects the overloaded platform.
- If the work range limit system fails, the outreach limit light blinks to indicate the failure. Stop using the machine and contact Aichi service shop for inspections, if this light blinks.

4. Upper control (Operation from platform)

Be sure to set the engine key switch in the UPPER control position to operate the machine from the platform.

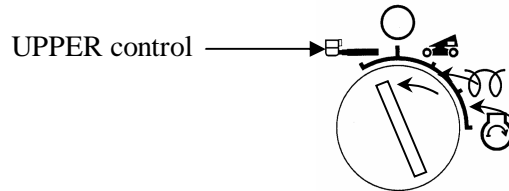

- DANGER**
- Always wear an authorized safety harness and hook its lanyard to the specified anchor after stepping on the platform.
 - Always stand on the platform floor firmly and maintain a safe posture.
 - Do not reach out of the platform.
- CAUTION**
- Prior to the operation, check that the platform is level. Adjust the platform level by operating the platform level adjust switch, if necessary.
 - When doing paintwork, first move the platform to the working position, and then be sure to close the cover of the upper control so that the decals do not become dirty.
 - Wipe off oil and water spilt on the platform floor so that personnel do not slip and fall on the platform.
 - Check the surroundings and make sure no obstacle around you or around the machine before operating the machine.
 - Especially be careful before rotating the boom. Check that no person or obstacle is around the turntable.
 - Do not put anything around the control levers, which may be caught in, causing unintended movements.

4.1 Foot-switch

Press down the foot switch to operate the machine on the platform. However, the following operations are available without pressing down the foot switch.

- Engine start operation
- Emergency stop operation
- Horn operation
- Work light operation (optional)
- Head light operation (optional)

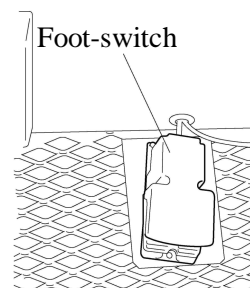

CAUTION Do not disable the foot-switch in any way e.g. by binding.

4.2 Travel operation

Use the travel control lever, the steering switch and the travel speed select switch to perform the traveling operations.

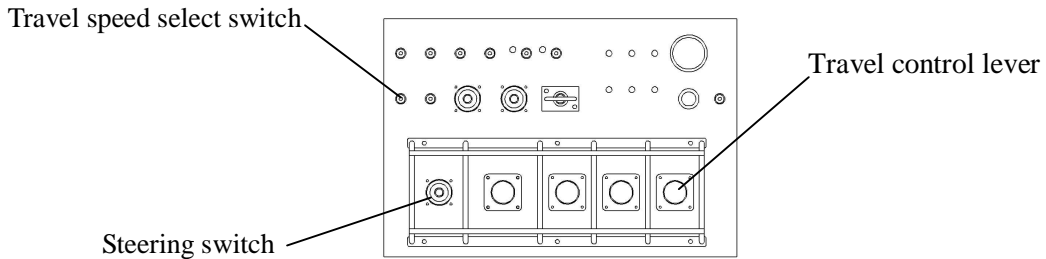

CAUTION When the turntable is rotated 180°, the traveling direction becomes opposite to the control lever operating direction. Before traveling, make sure the traveling direction of the machine by checking the arrow decals affixed on the chassis.

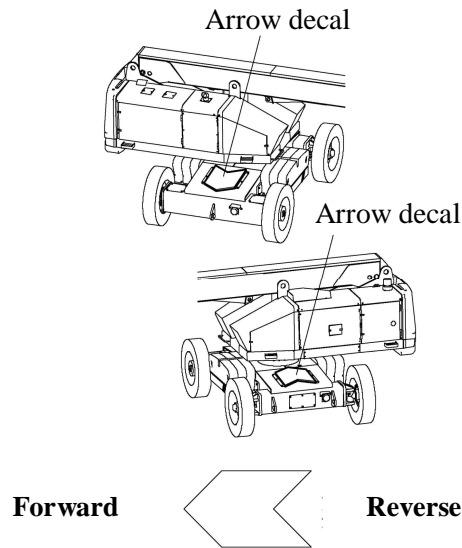

- CAUTION**
- Before traveling, make sure that no person or obstacle is in the traveling direction.
 - If traveling on rough terrain or on slope, retract the boom fully and set the boom under the horizontal.
 - Do not travel on rough terrain when the oscillation axle is locked. The oscillation axle locks under the following status.
 - 1) when the 2nd boom section is extended more than 1 meter (3ft – 3in) or the boom is raised over 15 degrees.
 - 2) When the boom is raised over 35 degrees while the boom is rotated within 80 degree range of the rear side of the chassis.
 - To start traveling, tilt the travel control lever gradually and start slowly.

- Personnel on board the platform must wear helmets and safety belts, and their safety belt lanyards must be hooked to the specified safety belt anchors.
- Avoid sudden turning.

4.2.1 Forward and reverse

Press down the foot switch and operate the travel control lever to the traveling direction.

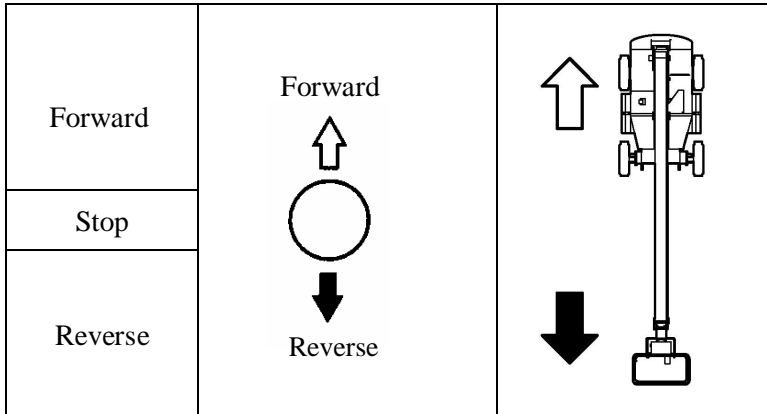

CAUTION • Make sure the traveling direction of the machine by checking the arrow decals affixed on the chassis, before traveling.

4.2.2 Left and right turns

Press down the foot switch and operate the steering switch.

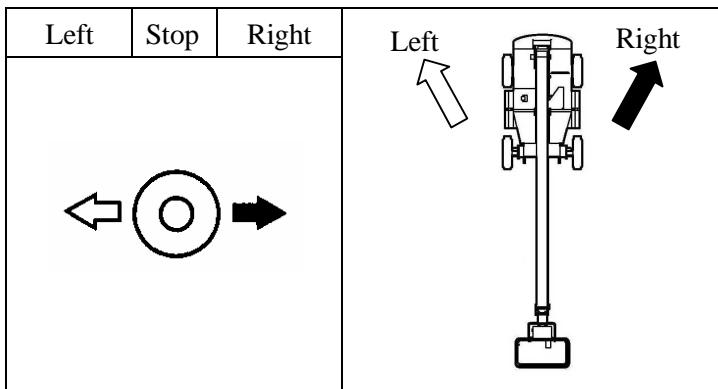

4.2.3 Travel speed select switch

The three traveling speeds low, mid and high can be selected with this switch.

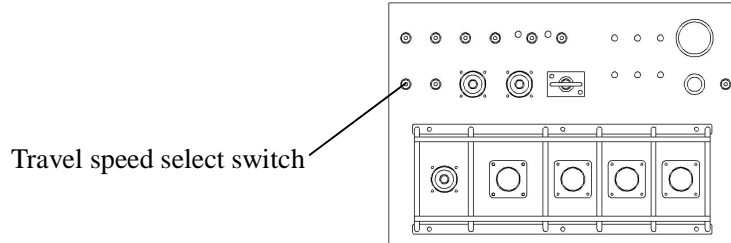

DANGER Select the low or mid traveling speed when making sharp turns. If making sharp turn with the high traveling speed, the platform will be swung roughly, causing personnel to drop from the platform.

- CAUTION**
- The engine rpm rises automatically during the high or mid speed traveling. Do not operate the travel speed select switch while traveling to avoid shocks that are caused by sudden change of the traveling speed.
 - The high and mid traveling speeds are available only when the boom is fully retracted and lowered below level. In other than these conditions, the high and mid traveling speeds cannot be obtained, even if the travel speed select switch is positioned at high or mid speed.
 - When traveling on rough terrain, retract the boom fully and set it under the horizontal, then position the travel speed select switch to mid speed so that you can obtain the largest traction.

4.3 Boom and Fly jib operation

Use the three boom control levers for the boom elevation, telescope and rotation to operate the boom, and the fly jib switch to operate the fly jib.

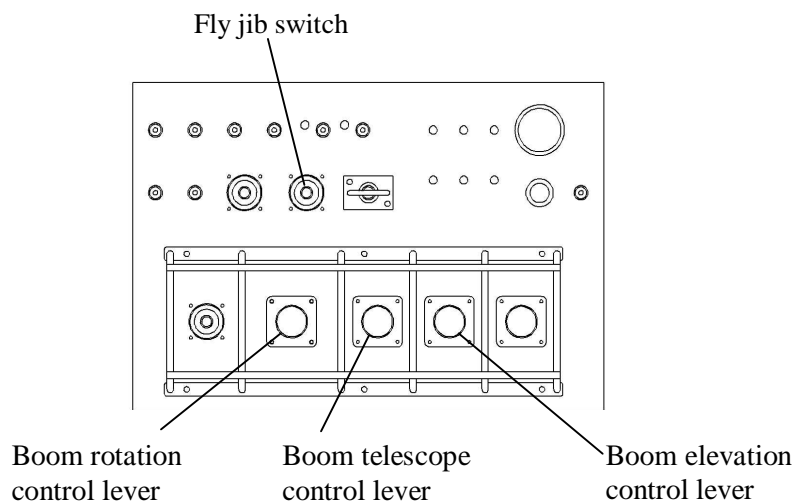

4.3.1 Boom raising and lowering operation

Press down the foot switch and operate the boom elevation control lever to raise or lower the boom.

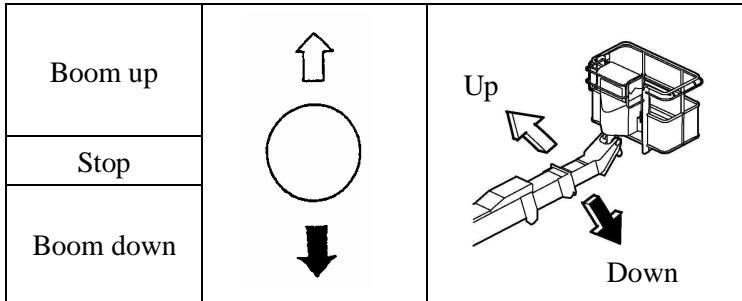

DANGER Do not press the boom and platform against ground by lowering the boom.

4.3.2 Boom rotating operation

Press down the foot switch and operate the boom rotation control lever to rotate the boom.

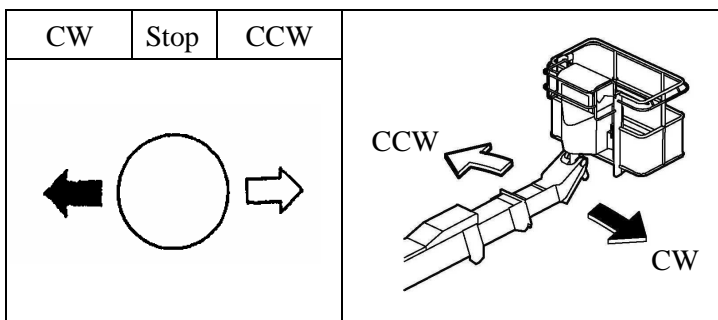

DANGER Before rotating the boom, make sure that no person or obstacle is around the turntable. Because, the turntable protrudes beyond the machine width.

CAUTION The boom may not be rotated smoothly when the machine is tilted.

4.3.3 Boom telescoping operation

Press down the foot switch and operate the boom telescope control lever to extend or retract the boom.

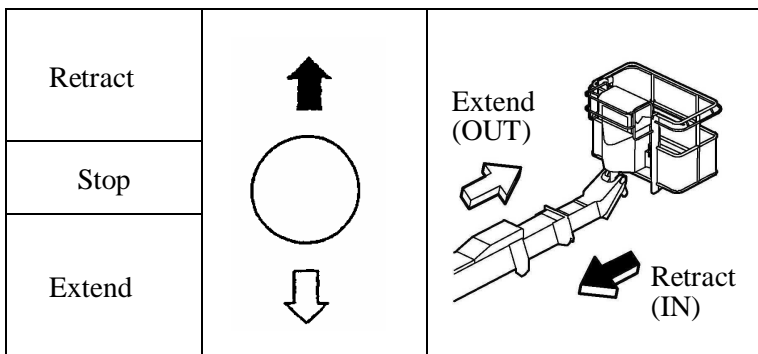

4.3.4 Fly jib operation

Press down the foot switch and operate the fly jib switch to raise or lower the fly jib.

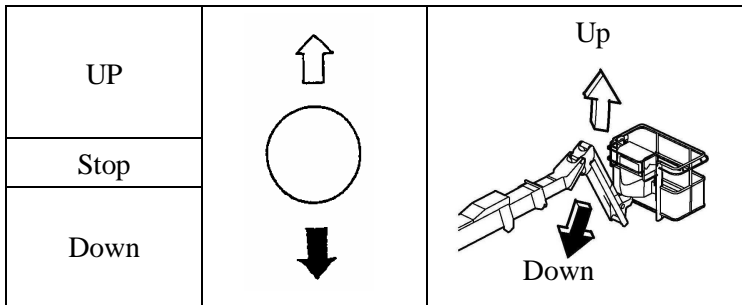

4.4 Horizontal and vertical movement operation

The horizontal / Vertical movement select switch and the boom elevation and telescope control levers are used for the horizontal and vertical movement.

- CAUTION**
- The accuracy of the horizontal and vertical movement is 0.4 m (15.7 inches), so pay attention to the obstacles near the platform to safely perform horizontal and vertical movement operations. Otherwise, the platform may interfere with the obstacles during the operation.
 - The horizontal and vertical movement stops automatically and the horizontal/vertical indicator light blinks, if the platform deviates from the moving route and reaches the accuracy limit (0.4 m or 15.7 in). To restart the operation, first return the control lever to the neutral position, and then operate the control lever again.

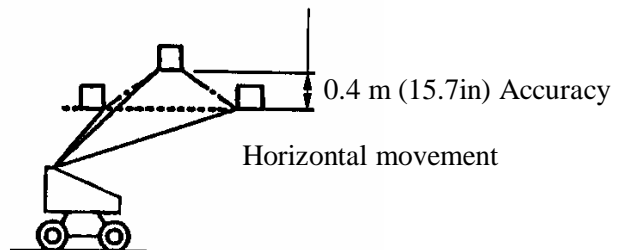
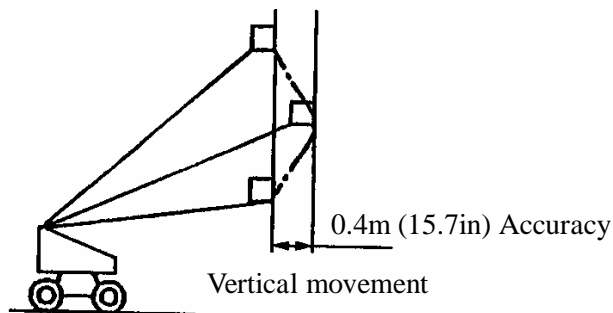

- (1) Turn on the horizontal/vertical movement select switch on the upper control panel and press the foot switch, then make sure that the horizontal/vertical movement light goes on.

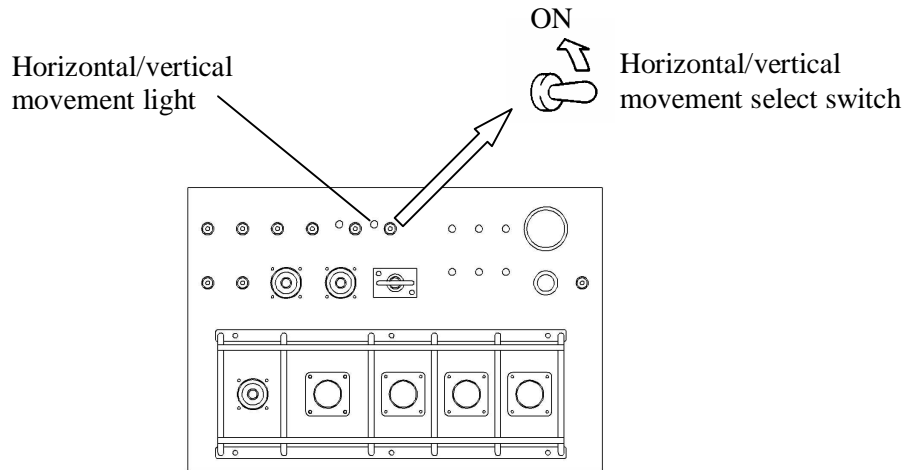

ADVICE The horizontal / vertical movement light does not go on, unless the foot-switch is pressed.

- (2) Vertical movement

Press down the foot switch and operate the boom elevation control lever to move the platform vertically.

UP		
Stop		
Down		

ADVICE The motion alarm buzzer sounds during the vertical movement.

(3) Horizontal movement

Press down the foot switch and operate the boom telescope control lever to move the platform horizontally.

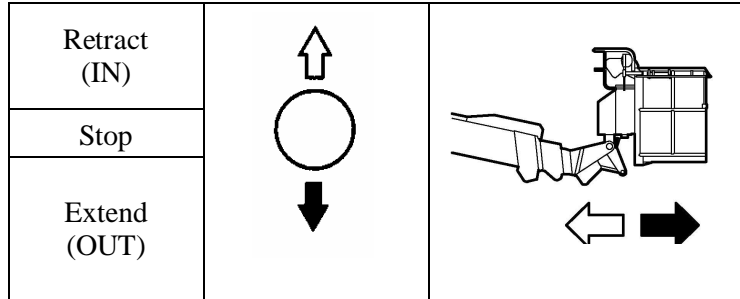

ADVICE The motion alarm buzzer sounds during the horizontal movement.

- (4) After completing the horizontal or vertical movement, be sure to turn off the horizontal/vertical movement select switch.

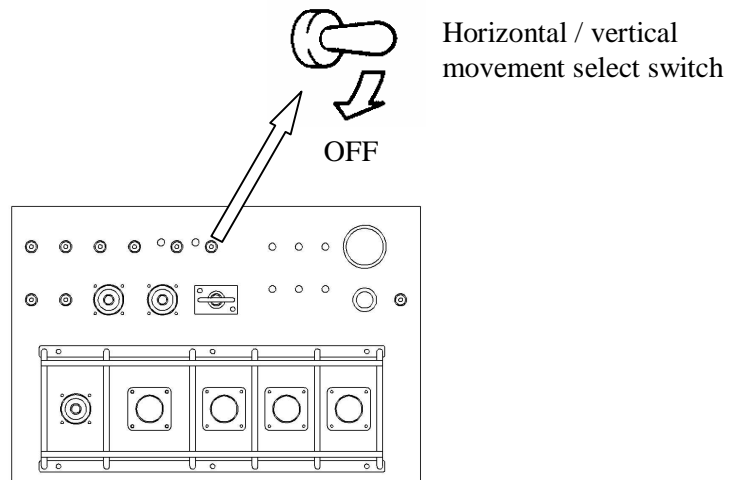

4.5 Platform rotating operation

Press down the foot switch and operate the platform rotation switch to rotate the platform.

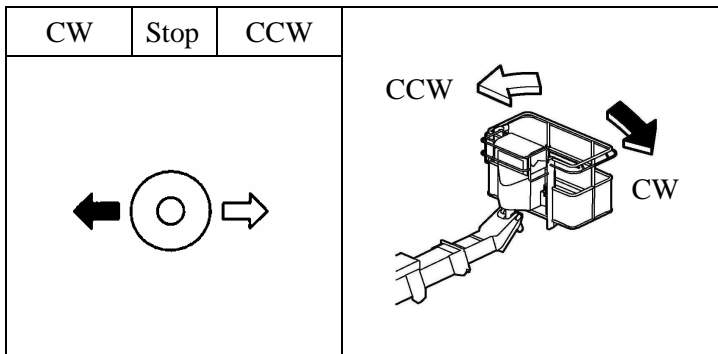

CAUTION Rotate the platform to the central position, before traveling.

4.6 Platform level adjusting operation

Press down the foot switch and operate the platform level adjust switch to adjust the platform level.

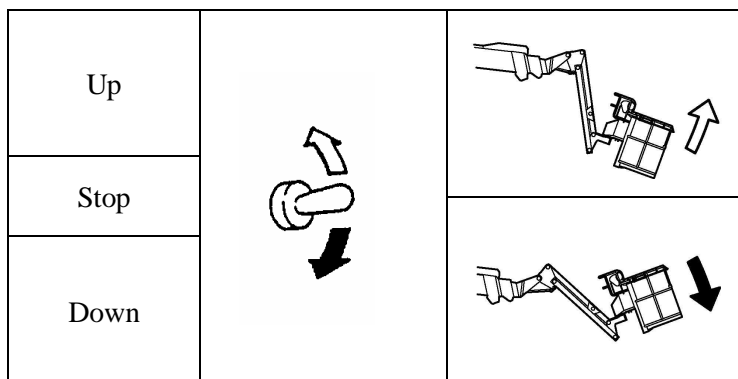
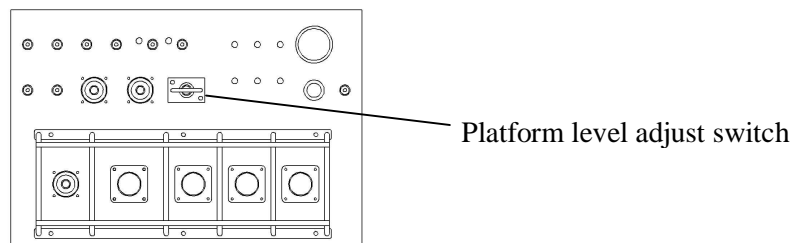

4.7 Emergency stop operation

Press the emergency stop switch. When this switch is pressed, the engine stops and all of the functions are disabled.

Press the emergency stop switch in the following cases:

- (1) To stop the engine.
- (2) When personnel on board the platform stops all of the machine movements to avoid danger.
- (3) When the machine is uncontrollable due to malfunction.

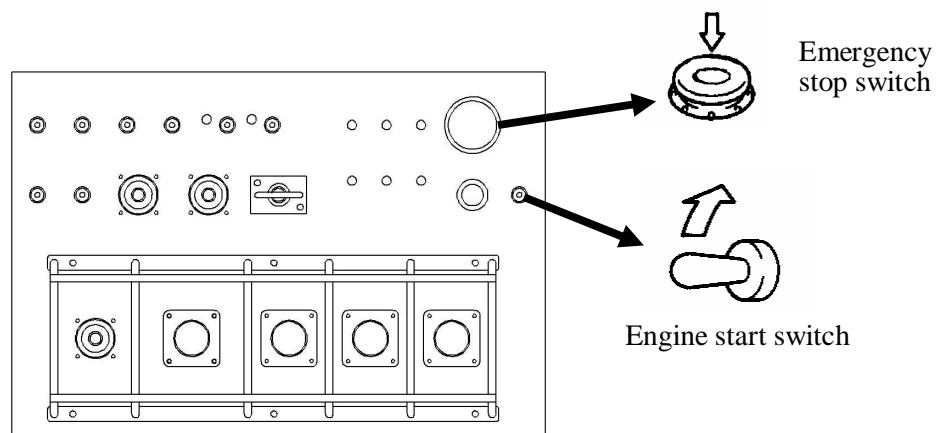

ADVICE To resume operation, pull the emergency stop switch.

- CAUTION**
- If the boom descends gradually after pressing the emergency stop switch, this may be caused by a natural descent of the hydraulic cylinder. In this case, restart the engine with the engine start switch and operate the boom to prevent the boom and the platform from coming into contact with any obstacles. Then, lower the platform to the ground and stop using the machine.
 - If the emergency stop operation was used as a result of malfunctions, stop using the machine and contact Aichi service shop for inspections.

4.8 Emergency pump operation

If the machine does not work due to engine or main pump failure, lower the platform using the emergency pump.

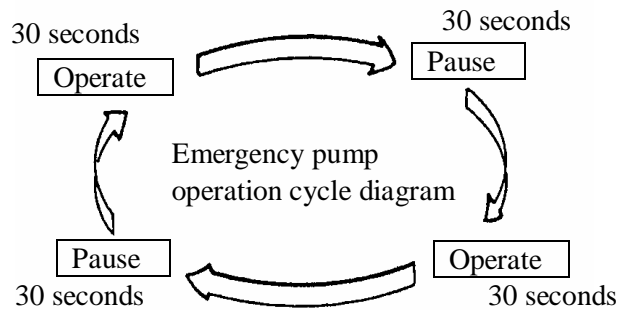
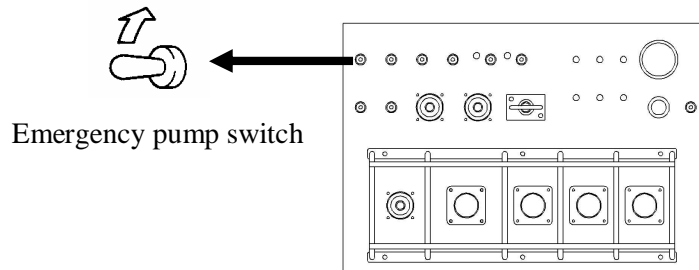

- CAUTION**
- Operate the emergency pump every other 30 seconds. The continuous operation in excess of 30 seconds may cause the damaged emergency pump.
 - Do not impose heavy load to the emergency pump, e.g. by attempting travelling operation.

4.9 Horn operation

The horn sounds when the horn switch is pressed. Sound the horn to warn personnel in the working area before starting operations.

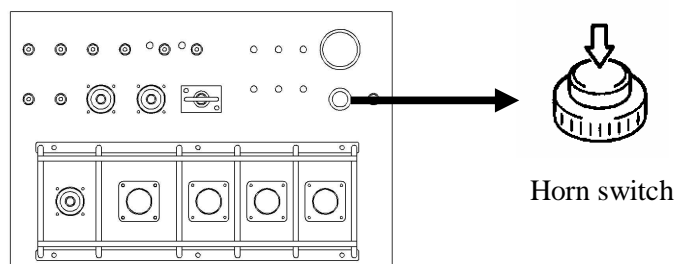

4.10 Indicator lights

The following indicator lights are installed on the upper control panel.

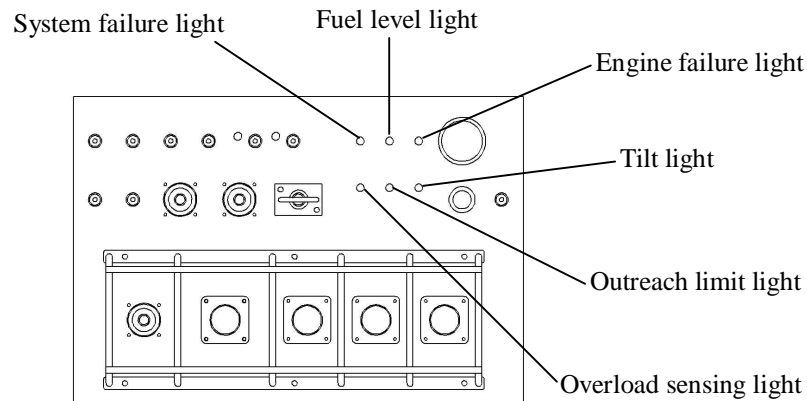

(1) Overload sensing light

When the platform is overloaded, this light blinks, the alarm buzzer sounds and all of the functions are disabled.

(2) System failure light

This light blinks, in the event of a computer control system failure.

Caution: Stop using the machine and contact Aichi service shop for inspections, if this light blinks. This light also blinks when the machine tilts excessively, but this is not a failure.

(3) Fuel level light

This light goes on when the fuel level is low. Refill with fuel when this light goes on.

(4) Outreach limit light

This light goes on when the work range limit system limits the outreach of the platform by disabling the boom extending and lowering functions.

Caution: This light blinks when any failure is in the work range limit system. Stop using the machine and contact Aichi service shop for inspections, if this light blinks.

(5) Engine failure light

This light goes on in the event of an engine failure, e.g. failed charging system, abnormally low oil pressure and abnormally high cooling water temperature. Check the indicator lights on the lower control panel to identify the cause.

(6) Tilt light

This light goes on and the alarm buzzer sounds when the machine tilts more than 5 degrees. Do not elevate the platform, if this light blinks.

XI Operating Point

Danger: Park the machine on firm and level surface before elevating the platform.

The machine may tip over, if parked on soft or uneven ground.

The maximum ground contact pressure of the machine is:

SP18AJ / ISP60J ----- 7.0 kg/cm² (100 PSI)

SP21AJ / ISP70J ----- 8.0 kg/cm² (114 PSI)

- (1) Park the machine close to the working target.

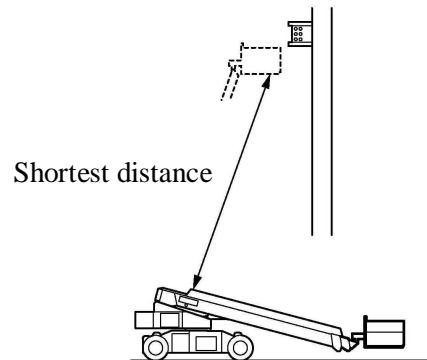

- (2) Rotate and elevate the boom till the working target is in line with the boom extending direction.

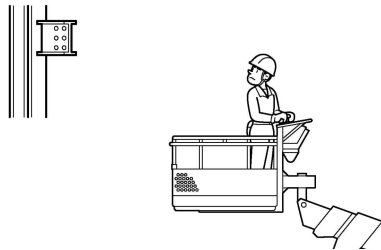

- (3) Extend the boom till the working target is within a comfortable working range.

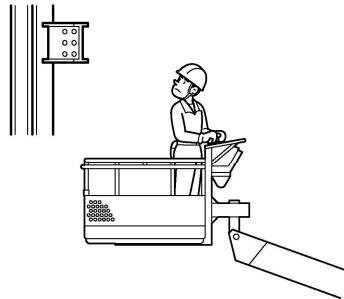

ADVICE Rotate the platform, if necessary.

- (4) After finishing the work, reverse the above procedures to lower the platform.

XII Towing

If the machine does not travel due to engine or main pump failure, disengage the clutch installed on each travel gearbox for towing the machine.

1. Clutch disengagement

DANGER Never disengage the clutch on a slope as this may cause the machine to roll, which may result in serious injury or death.

- (1) Remove the cap on each travel gearbox.

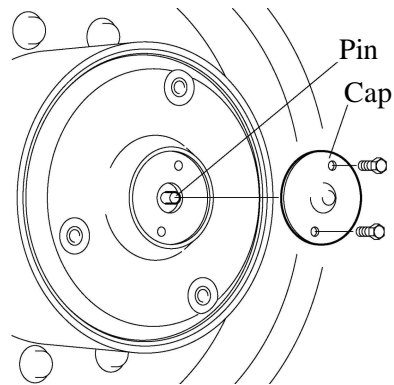

- (2) Reverse the cap and reinstall it on each travel gearbox to disengage the clutch.

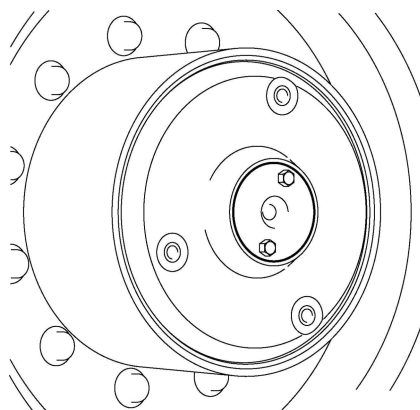

CAUTION Do not attempt the travelling operations while the clutch is disengaged, as this may damage the travel mechanism.

- (3) Tow the machine by connecting a towing chain or rod to the towing rings installed on the chassis.

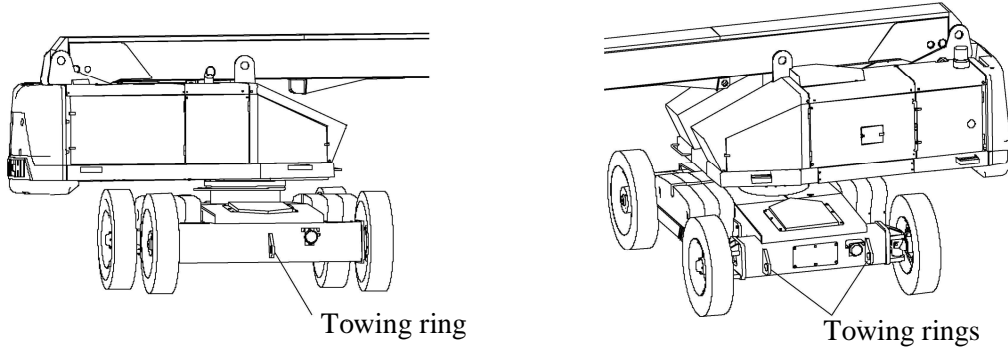

2. Clutch re-engagement

- (1) Remove the cap from each travel gearbox.

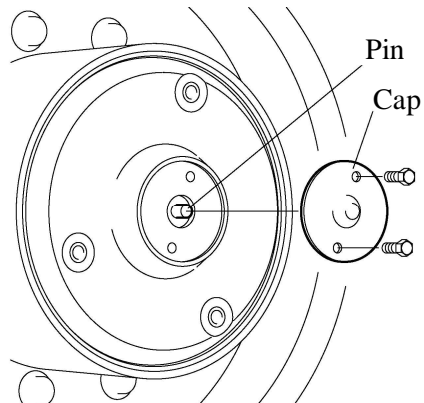

- (2) Reverse the cap and re-install it on each travel gearbox to re-engage the clutch.

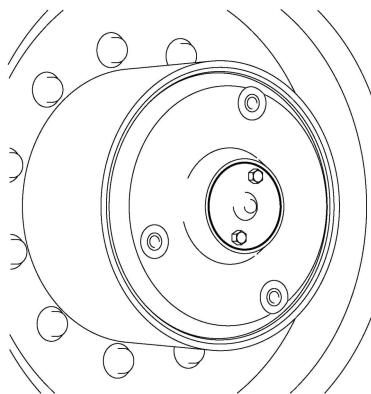

XIII Transportation

1. When using loading ramp

When transporting the machine by a transport vehicle, observe the following items:

- (1) Load/unload the machine to/from the transport vehicle on firm and level surface.

- DANGER**
- The wheels of the machine may fall off, if the transport vehicle or the loading ramps incline excessively.
 - Use a winch for loading/unloading, if the ramp is too steep or slippery.

- CAUTION**
- When loading and unloading, be sure to have a guide assist you so that the wheels do not fall off the ramp and the transport vehicle bed.
 - The system failure light may blink when the machine tilts excessively on the loading ramps. This is not failure.

- (2) Be sure to lock the turntable by inserting the rotation lock pin and prevent the turntable from being rotated during the transportation.

- CAUTION**
- Rotate the turntable slowly to align the both rotation lock pin holes on the turntable and the chassis, then insert the rotation lock pin in their holes.

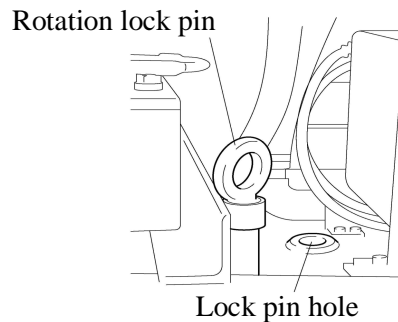

- (3) Check that all doors and covers of the machine are closed and latched securely.
- (4) Tie down the chassis of the machine to the transport vehicle bed securely.
- (5) Tie down the fly jib with placing a wood block under the fly jib head to prevent the boom and the fly jib from bouncing during the transportation.
- (6) Tie down the platform so that it is not swung during the transportation. At this time, be sure to allow the clearance between the bottom of the platform and the transport vehicle bed.

- (7) Do not tighten the tie down chains marked (*) too much. Tighten them just so that the platform is not swung or bounced during the transportation.

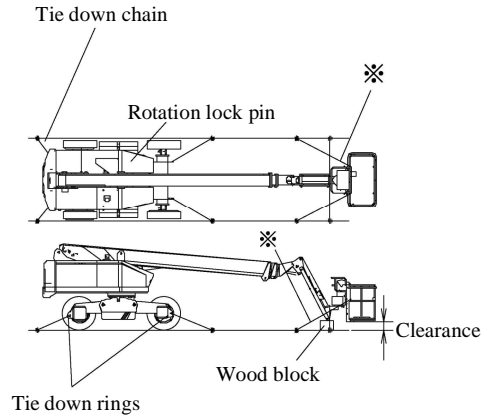

2. When hoisting

Pass the sling chains or wire ropes through the hoisting rings located on the turntable and hoist the machine slowly.

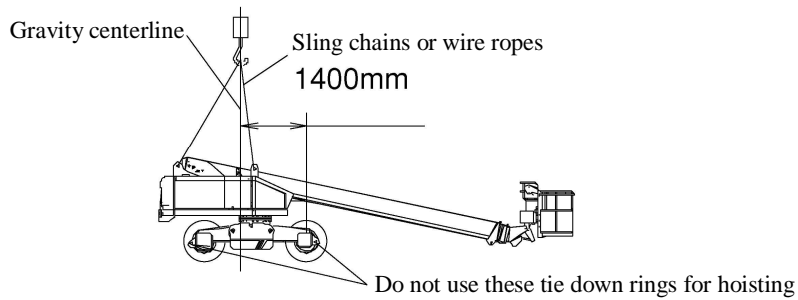

CAUTION

- Use a sling chains or wire ropes strong enough to withstand the weight of the machine.

Model	Specifications		Weight
SP18AJ / ISP60J	CE Spec.		12,300 kg (27,200 LBS)
	USA Spec.	The machine with foam filled tires	10,900 kg (24,000 LBS)
		The machine with air filled tires	10,900 kg (24,000 LBS)
SP21AJ / ISP70J	CE spec.		14,700 kg (32,400 LBS)
	USA Spec.	The machine with foam filled tires.	14,100 kg (31,100 LBS)
		The machine with air filled tires.	13,700 kg (30,200 LBS)

- Be sure to retract and lower the boom fully before hoisting the machine.

XIV Lubrication

1. Recommended lubricants

Manufacturers	Hydraulic oil		Gear oil	Grease		
	General purpose	For cold region		General	Gear compound	Molybdenum
Shell oil	Tellus oil T22	Fluid special	Spirax EP 90	Alvania EP grease 2	Cardium compound A or D	Retinax AM
Esso oil	Uni power XL22	-	Standard gear oil 90	Lithtan EP2	JWS2563	Beacon Q2
Mobil oil	Hydraulic oil K22	EJ60/196C	Pegasus gear oil 90	Mobilux EP2	Mobiltac QQ	Mobil grease special
Nippon oil	Highland wide 22	Highland AH15	Gearlube SP90	Epiknock AP2	Cranoc compound 1	New molynock 2
Idemitsu kosan	Daphne super hydro X22	Daphne hydro GT	Apolo gear HE90	Daphne eponex grease EP No.2	Daphne open gear oil No.1	Daphne grease M No.2
Cosmo oil	Cosmo hydro HV22	Cosmo hydro HV15K	Cosmo gear GL-4-90	Cosmo grease diner Max EP No.2	Cosmo gear compound No.2	Cosmo molybdenum grease No.2
Japan energy	Hydrax ES22	Hydrax LT15	Gear 4-90	Resonics grease EP-2	Gear compound No.2	Resonics grease M-2
Mitsubishi oil	Diamond hydro W22	-	Diamond hypoid gear oil 90	Diamond multipurpose EP grease 2	Mitsubishi gear compound 2	Diamond multipurpose M grease 2
General oil	Hydro fluid AW wide 22	-	G gear 4-90	Gemico grease ME-2	General gear compound 2	Gemico grease AD-1

NOTE Apply machine oil to the hinges as needed.

2. Lubricating points and intervals

2.1 Lubricate every 100 hours or one month

Lubricant: grease (general)

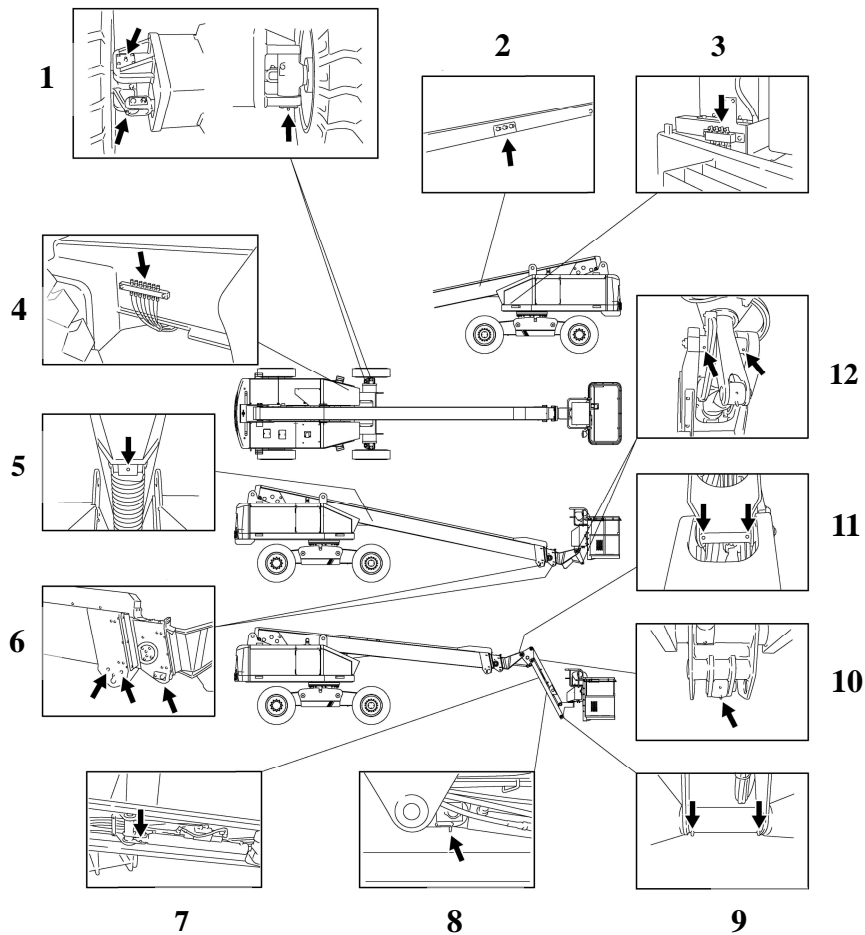

No	Lubricating points.
1	King pins.
2	Boom pivot pin and Anchor pin for Lower leveling cylinder.
3	Rotation bearing, Swivel joint, Anchor pins for Elevation cylinder and Lower leveling cylinder.
4	Pins for steering linkages.
5	Anchor pin for Elevation cylinder.
6	Boom rollers.
7	Anchor pin for Fly jib cylinder.
8	Anchor pin for Fly jib cylinder.
9	Pin for Fly jib linkage.
10	Anchor pin for Upper leveling cylinder.
11	Pin for Fly jib linkage.
12	Platform pivot pin.

2.2 Change oil every 1,200 hours or 12 months

(After 300 hours or 3 months for the new machine)

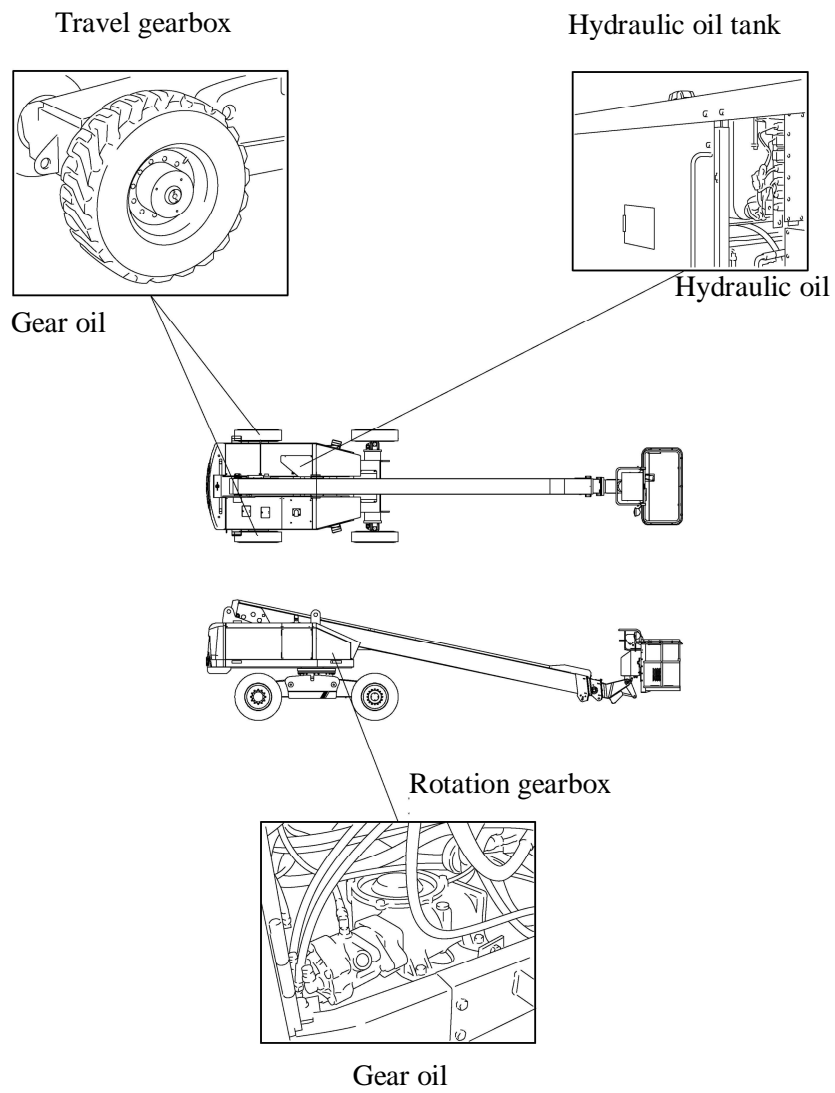

XV Daily Care

Various materials are used in the construction of this machine and these materials wear or deteriorate gradually. Some parts may be difficult to check for safety, so those parts should be replaced periodically according to the predetermined serviceable life time.

1. Hydraulic oil

1.1 Replenishing

Check the hydraulic oil level with the oil level gauge and replenish to the specific level through the oil filler cap.

NOTE Before checking the oil level, retract and lower the boom fully.

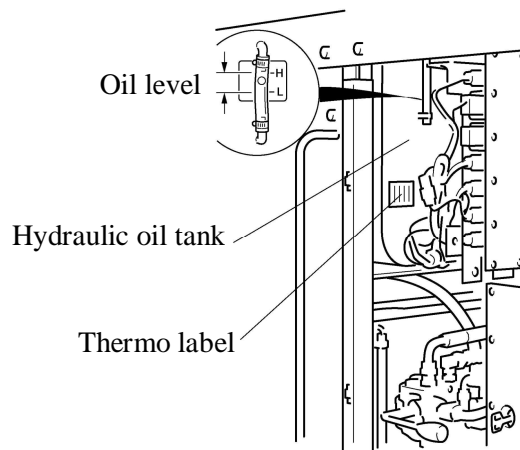

1.2 Changing oil (Once a year or every 1200 hours)

- (1) Retract and lower the boom fully.
- (2) Remove the oil drain plug and drain the hydraulic oil thoroughly, then reinstall the oil drain plug.
- (3) Refill the tank with new hydraulic oil with checking the oil level.
- (4) Replace the hydraulic filters at the same time.

ADVICE Oil tank capacity: 150 liters (39.6 gallons).

2. Gear oil for Rotation gearbox

Change the gear oil once a year or every 1200 hours

NOTE • Oil capacity: 1.7 liters (0.45 gallons)

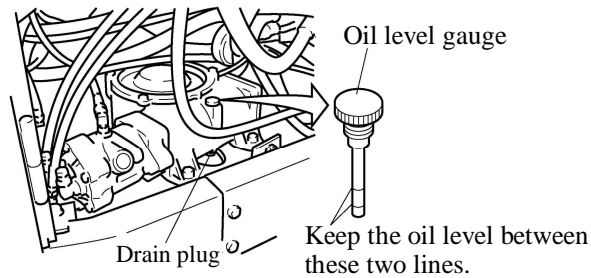

3. Gear oil for Travel gearbox

NOTE • Oil capacity: 1.7 liters (0.45 gallons)

- (1) Travel the machine and position the oil drain plug to the bottom of the travel gearbox as shown in the figure below.
- (2) Remove all of the plugs and drain the gear oil thoroughly, then reinstall the oil drain plug.
- (4) Refill the gearbox through the oil filler port with new gear oil till the oil level reaches the oil level port.
- (5) Reinstall the oil filler and level plugs.

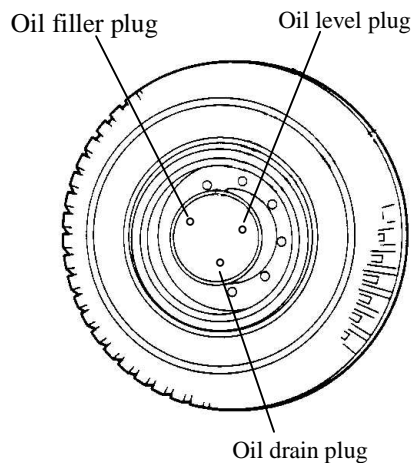

4. Engine

See the engine manufacturer's manual for the detail of engine maintenance.

A long life coolant (freezing temperature of -40°C) is filled in the new machine by Aichi before shipping.

5. Wire ropes

Change the wires rope, if any defects listed below are observed.

- (1) Kinked rope
- (2) Stretched or corroded rope.
- (3) Cut rope (If more than 3 core wires in one lay of the wire rope are cut).
- (4) Worn out rope. (If the decrease of the rope diameter exceeds 3 percent of the nominal diameter. See the figure below to check the diameter.)

NOTE For detail, contact Aichi service shop.

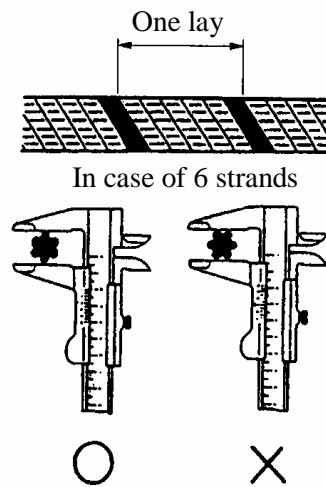

6. Fuses

The fuse holder is located on the lower control panel. If the machine does not work, the fuse may have been blown.

ADVICE When replacing fuse, be sure to turn the engine key switch to OFF position.

10A	5A	5A	5A	10A	5A
Engine start	Emergency pump	Lower control	Upper control	Horn	Hour meter
20A		10A		5A	
CPU, Upper	Engine	CPU, Lower	Work light	Glow (Fuel pump)	Fuse removing tool
20A	20A	10A	10A	5A	

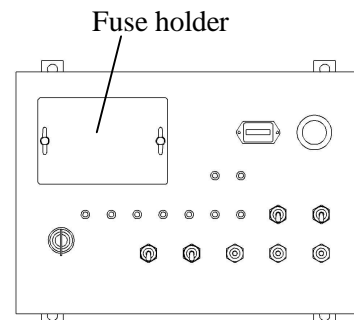

Fuse holder detail

7. Hydraulic hose

If oil leaks from the hydraulic hose, stop using the machine immediately and contact Aichi service shop. When ordering the hydraulic hose, notify the following items to the service shop.

- (1) Type of the hydraulic hose: Rubber or Nylon.
- (2) Installed location of the hydraulic hose.
- (3) Length of the hydraulic hose:
The dimension between the tips of the both hose fittings.
The hose length is indicated on the "Hose fitting" as shown in the figure below.
But, this is for rubber hose only.

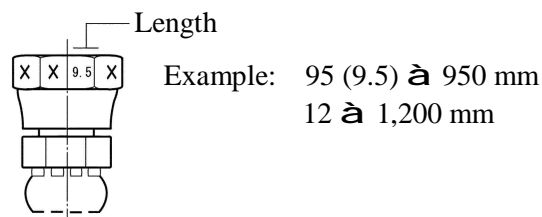

- (4) Type of the hose fittings.

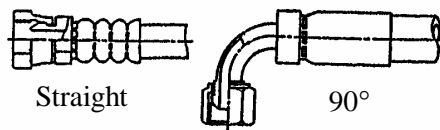

- (5) Size of the hose (identify the wrench size of the hose fitting)

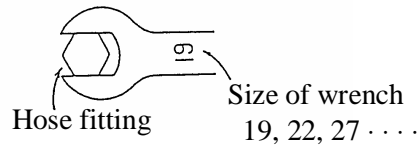

- (6) The hose armour

1 Both end armoured

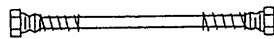

2 Fully-armoured

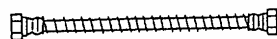

3 Non-armoured

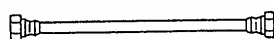

XVI Storage for Long Periods

- (1) Clean each part of the machine.

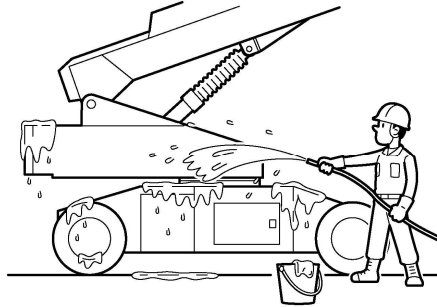

CAUTION • Do not wash the electrical components especially with pressurized water.

- (2) Lubricate each part of the machine thoroughly.

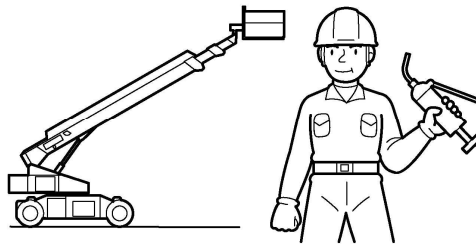

- (3) Apply rust-preventive oil to the cylinder rods.

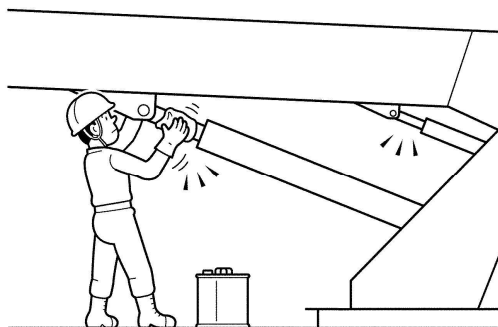

CAUTION If the cylinder is left without rust prevention oil, it may rust.

- (4) Store in a dry room.

If outdoor storage is unavoidable, park the machine on firm and level surface and cover the machine with a waterproof sheet.

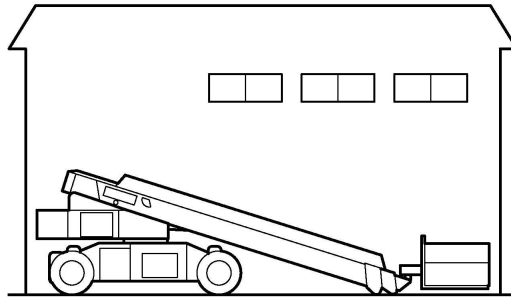

- (5) Operate the machine periodically to prevent corrosion of the lubricated sections.

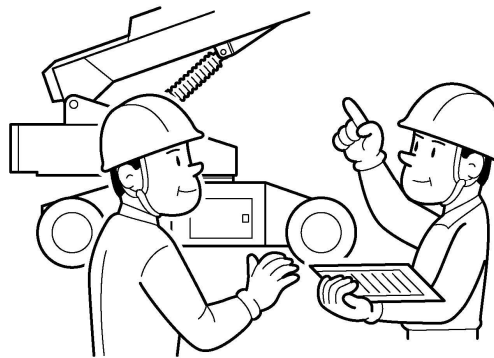

CAUTION Wipe off the rust prevention oil applied on the cylinder rods before operating the machine.

XVII Optional Equipment Operating Method

Optional equipments are installed on the request of the customer, so the items here may not always be equipped to the machine.

1. Work light

When the work light switch on the upper control panel is turned on, the work light goes on.

CAUTION If the work light is kept lit while the engine is stopped, the battery on the machine may be dead. Use the work light when the engine is in motion.

2. Rotating beacon

The rotating beacon goes on as soon as the engine starts.

3. AC power outlet

Connect the mains to the AC input plug located at the turntable before using the electrical tools on the platform.