



An Oshkosh Corporation Company

Operation and Safety Manual

Original Instructions - Keep this manual with the machine at all times.

Boom Lift Models 150HAX



3121213
August 30, 2012

FOREWORD

This manual is a very important tool! Keep it with the machine at all times.

The purpose of this manual is to provide owners, users, operators, lessors, and lessees with the precautions and operating procedures essential for the safe and proper machine operation for its intended purpose.

Due to continuous product improvements, JLG Industries, Inc. reserves the right to make specification changes without prior notification. Contact JLG Industries, Inc. for updated information.

SAFETY ALERT SYMBOLS AND SAFETY SIGNAL WORDS



This is the Safety Alert Symbol. It is used to alert you to the potential personal injury hazards. Obey all safety messages that follow this symbol to avoid possible injury or death

DANGER

INDICATES AN IMMINENTLY HAZARDOUS SITUATION. IF NOT AVOIDED, WILL RESULT IN SERIOUS INJURY OR DEATH. THIS DECAL WILL HAVE A RED BACKGROUND.

WARNING

INDICATES A POTENTIALLY HAZARDOUS SITUATION. IF NOT AVOIDED, COULD RESULT IN SERIOUS INJURY OR DEATH. THIS DECAL WILL HAVE AN ORANGE BACKGROUND.

CAUTION

INDICATES A POTENTIALLY HAZARDOUS SITUATION. IF NOT AVOIDED, MAY RESULT IN MINOR OR MODERATE INJURY. IT MAY ALSO ALERT AGAINST UNSAFE PRACTICES. THIS DECAL WILL HAVE A YELLOW BACKGROUND.

NOTICE

INDICATES INFORMATION OR A COMPANY POLICY THAT RELATES DIRECTLY OR INDIRECTLY TO THE SAFETY OF PERSONNEL OR PROTECTION OF PROPERTY.

⚠ WARNING

THIS PRODUCT MUST COMPLY WITH ALL SAFETY RELATED BULLETINS. CONTACT JLG INDUSTRIES, INC. OR THE LOCAL AUTHORIZED JLG REPRESENTATIVE FOR INFORMATION REGARDING SAFETY-RELATED BULLETINS WHICH MAY HAVE BEEN ISSUED FOR THIS PRODUCT.

NOTICE

JLG INDUSTRIES, INC. SENDS SAFETY RELATED BULLETINS TO THE OWNER OF RECORD OF THIS MACHINE. CONTACT JLG INDUSTRIES, INC. TO ENSURE THAT THE CURRENT OWNER RECORDS ARE UPDATED AND ACCURATE.

NOTICE

JLG INDUSTRIES, INC. MUST BE NOTIFIED IMMEDIATELY IN ALL INSTANCES WHERE JLG PRODUCTS HAVE BEEN INVOLVED IN AN ACCIDENT INVOLVING BODILY INJURY OR DEATH OF PERSONNEL OR WHEN SUBSTANTIAL DAMAGE HAS OCCURRED TO PERSONAL PROPERTY OR THE JLG PRODUCT.

For:

- Accident Reporting
- Product Safety Publications
- Current Owner Updates
- Questions Regarding Product Safety
- Standards and Regulations Compliance Information
- Questions Regarding Special Product Applications
- Questions Regarding Product Modifications

Contact:

Product Safety and Reliability Department
JLG Industries, Inc.
13224 Fountainhead Plaza
Hagerstown, MD 21742
USA

or Your Local JLG Office
(See addresses on inside of manual cover)

In USA:

Toll Free: 877-JLG-SAFE (877-554-7233)

Outside USA:

Phone: 240-420-2661
Fax: 301-745-3713
E-mail: ProductSafety@JLG.com

REVISION LOG

| | |
|----------------|---------------------|
| Original Issue | - July 19, 2005 |
| Revised | - August 8, 2006 |
| Revised | - November 30, 2009 |
| Revised | - August 30, 2012 |

| SECTION - PARAGRAPH, SUBJECT | PAGE |
|---|-------------|
| SECTION - 1 - SAFETY PRECAUTIONS | |
| 1.1 GENERAL | 1-1 |
| 1.2 PRE-OPERATION | 1-1 |
| Operator Training and Knowledge | 1-1 |
| Workplace Inspection | 1-2 |
| Machine Inspection | 1-2 |
| 1.3 OPERATION | 1-3 |
| General | 1-3 |
| Trip and Fall Hazards | 1-3 |
| Electrocution Hazards | 1-4 |
| Tipping Hazards | 1-6 |
| Crushing and Collision Hazards | 1-7 |
| 1.4 TOWING, LIFTING, AND HAULING | 1-8 |
| 1.5 ADDITIONAL HAZARDS / SAFETY | 1-9 |
| SECTION - 2 - USER RESPONSIBILITIES, MACHINE PREPARATION, AND INSPECTION | |
| 2.1 PERSONNEL TRAINING | 2-1 |
| Operator Training | 2-1 |
| Training Supervision | 2-1 |
| Operator Responsibility | 2-1 |
| 2.2 PREPARATION, INSPECTION, AND MAINTENANCE | 2-2 |
| Pre-Start Inspection | 2-4 |
| Function Check | 2-5 |

| SECTION - PARAGRAPH, SUBJECT | PAGE |
|--|-------------|
| GENERAL | 2-7 |
| 2.3 DAILY FUNCTIONAL CHECK | 2-10 |
| Axle Extension System | 2-10 |
| Axle Retraction System | 2-11 |
| Function Cut-Outs and Restrictions | 2-11 |
| Tower Boom Sequence | 2-13 |
| Tower Boom Lift and Swing Systems | 2-14 |
| Tower Boom Telescope System | 2-14 |
| Main Boom Lift System | 2-14 |
| Main Boom Telescope System | 2-14 |
| Platform Leveling Systems | 2-15 |
| Platform Rotator | 2-15 |
| Drive System | 2-15 |
| Steer System | 2-15 |
| Footswitch | 2-15 |
| Auxiliary Power | 2-15 |
| Ground Controls | 2-15 |

| SECTION - 3 - MACHINE CONTROLS AND INDICATORS | |
|--|------|
| 3.1 GENERAL | 3-1 |
| 3.2 CONTROLS AND INDICATORS | 3-1 |
| Ground Control Panel | 3-1 |
| Ground Control Remote Box | 3-6 |
| Platform Control Station | 3-10 |

TABLE OF CONTENTS

| SECTION - PARAGRAPH, SUBJECT | PAGE | SECTION - PARAGRAPH, SUBJECT | PAGE |
|--|------|--|------|
| SECTION - 4 - MACHINE OPERATION | | | |
| 4.1 DESCRIPTION | 4-1 | 4.9 SHUT-DOWN AND PARK | 4-10 |
| 4.2 OPERATING CHARACTERISTICS AND LIMITATIONS | 4-1 | 4.10 TIE DOWN AND LIFTING | 4-11 |
| Capacities | 4-1 | Tie Down | 4-11 |
| Stability | 4-1 | Lifting | 4-11 |
| 4.3 ENGINE OPERATION | 4-2 | 4.11 TOWING | 4-11 |
| Starting Procedure | 4-2 | | |
| Shutdown Procedure | 4-5 | SECTION - 5 - EMERGENCY PROCEDURES | |
| 4.4 TRAVELING (DRIVING) | 4-5 | 5.1 GENERAL | 5-1 |
| Traveling Forward and Reverse | 4-7 | 5.2 INCIDENT NOTIFICATION | 5-1 |
| 4.5 STEERING | 4-7 | 5.3 EMERGENCY TOWING PROCEDURES | 5-1 |
| 4.6 PARKING AND STOWING | 4-7 | 5.4 EMERGENCY CONTROLS AND THEIR LOCATIONS | 5-2 |
| 4.7 PLATFORM | 4-8 | Ignition/Emergency Stop Switch | 5-2 |
| Loading From Ground Level | 4-8 | Ground Control Station | 5-2 |
| Loading From Positions Above Ground Level | 4-8 | Auxiliary Power | 5-2 |
| Platform Level Adjustment | 4-8 | Manual Descent and Retraction | 5-3 |
| Platform Rotation | 4-8 | 5.5 EMERGENCY OPERATION | 5-4 |
| 4.8 BOOM | 4-9 | Use of Ground Controls | 5-4 |
| Swinging the Boom | 4-9 | Operator Unable to Control Machine | 5-4 |
| Raising and Lowering the Boom | 4-10 | Platform or Boom Caught Overhead | 5-4 |
| Telescoping the Tower Boom | 4-10 | | |
| Telescoping the Main Boom | 4-10 | SECTION - 6 - GENERAL SPECIFICATIONS & OPERATOR | |

| SECTION - PARAGRAPH, SUBJECT | PAGE |
|--|-------------|
| MAINTENANCE | |
| 6.1 INTRODUCTION | 6-1 |
| 6.2 OPERATING SPECIFICATIONS | 6-1 |
| Capacities | 6-2 |
| Engine | 6-2 |
| Tires | 6-3 |
| Dimensional Data | 6-3 |
| Hydraulic Oil | 6-4 |
| Critical Stability Weights | 6-6 |
| Serial Number Locations | 6-7 |
| 6.3 OPERATOR MAINTENANCE | 6-11 |
| 6.4 TIRES & WHEELS | 6-24 |
| Tire Inflation | 6-24 |
| Tire Damage | 6-24 |
| Tire Replacement | 6-24 |
| Wheel Replacement | 6-25 |
| Wheel Installation | 6-25 |
| 6.5 SUPPLEMENTAL INFORMATION | 6-26 |
| SECTION - 7 - INSPECTION AND REPAIR LOG | |

| SECTION - PARAGRAPH, SUBJECT | PAGE |
|--|-------------|
| LIST OF FIGURES | |
| 2-1. Daily Walk-Around Inspection - Sheet 1 of 4 | 2-6 |
| 2-2. Daily Walk-Around Inspection - Sheet 2 of 4 | 2-7 |
| 2-3. Daily Walk-Around Inspection - Sheet 3 of 4 | 2-8 |
| 2-4. Daily Walk-Around Inspection - Sheet 4 of 4 | 2-9 |
| 3-1. Ground Control Panel - Sheet 1 of 3 | 3-3 |
| 3-2. Ground Control Panel - Sheet 2 of 3 | 3-4 |
| 3-3. Ground Control Panel - Sheet 3 of 3 | 3-5 |
| 3-4. Ground Control Remote Box | 3-7 |
| 3-5. Platform Control Station | 3-11 |
| 4-1. Position of Least Forward Stability | 4-3 |
| 4-2. Position of Least Backward Stability | 4-4 |
| 4-3. Grade and Sideslope | 4-6 |
| 4-4. Lifting Diagram | 4-12 |
| 4-5. Decal Installation- Sheet 1 of 2 | 4-13 |
| 4-6. Decal Installation- Sheet 2 of 2 | 4-14 |
| 6-1. Serial Number Locations | 6-7 |
| 6-2. Engine Operating Temperature Specifications - Cummins - Sheet 1 of 2 | 6-8 |
| 6-3. Engine Operating Temperature Specifications - Cummins - Sheet 2 of 2 | 6-9 |
| 6-4. Operator Maintenance & Lubrication Diagram | 6-10 |

TABLE OF CONTENTS

| SECTION - PARAGRAPH, SUBJECT | PAGE | SECTION - PARAGRAPH, SUBJECT | PAGE |
|------------------------------|--|------------------------------|------|
| LIST OF TABLES | | | |
| 1-1 | Minimum Approach Distances (M.A.D.) | 1-5 | |
| 1-2 | Beaufort Scale (For Reference Only) | 1-10 | |
| 2-1 | Inspection and Maintenance Table | 2-3 | |
| 4-1 | Decal Installation - Prior to S/N 0300103758 | 4-15 | |
| 4-2 | Decal Installation - S/N 0300103758 to Present | 4-19 | |
| 6-1 | Operating Specifications | 6-1 | |
| 6-2 | Capacities | 6-2 | |
| 6-3 | Cummins 4B3.9C | 6-2 | |
| 6-4 | Cummins QSB4.5-NA | 6-2 | |
| 6-5 | Tires | 6-3 | |
| 6-6 | Dimensional Data | 6-3 | |
| 6-7 | Hydraulic Oil | 6-4 | |
| 6-8 | Mobilfluid 424 Specs | 6-4 | |
| 6-9 | Mobil EAL 224 H Specs | 6-5 | |
| 6-10 | Mobil DTE 13M Specs | 6-5 | |
| 6-11 | Exxon Univil HVI 26 Specs | 6-6 | |
| 6-12 | Critical Stability Weights | 6-6 | |
| 6-13 | Lubrication Specifications | 6-11 | |
| 6-14 | Wheel Torque Chart | 6-26 | |
| 7-1 | Inspection and Repair Log | 7-1 | |

SECTION 1. SAFETY PRECAUTIONS

1.1 GENERAL

This section outlines the necessary precautions for proper and safe machine operation and maintenance. For proper machine use, it is mandatory that a daily routine is established based on the content of this manual. A maintenance program, using the information provided in this manual and the Service and Maintenance Manual, must also be established by a qualified person and followed to ensure the machine is safe to operate.

The owner/user/operator/lessor/lessee of the machine should not operate the machine until this manual has been read, training is accomplished, and operation of the machine has been completed under the supervision of an experienced and qualified operator.

If there are any questions with regard to safety, training, inspection, maintenance, application, and operation, please contact JLG Industries, Inc. (“JLG”).

WARNING

FAILURE TO COMPLY WITH THE SAFETY PRECAUTIONS LISTED IN THIS MANUAL COULD RESULT IN MACHINE DAMAGE, PROPERTY DAMAGE, PERSONAL INJURY OR DEATH.

1.2 PRE-OPERATION

Operator Training and Knowledge

- Read and understand this manual before operating the machine.

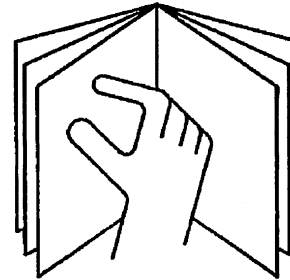

- Do not operate this machine until complete training is performed by authorized persons.
- Only authorized and qualified personnel can operate the machine.

SECTION 1 - SAFETY PRECAUTIONS

- Read, understand, and obey all DANGERS, WARNINGS, CAUTIONS, and operating instructions on the machine and in this manual.
- Use the machine in a manner which is within the scope of its intended application set by JLG.
- All operating personnel must be familiar with the emergency controls and emergency operation of the machine as specified in this manual.
- Read, understand, and obey all applicable employer, local, and governmental regulations as they pertain to operation of the machine.

Workplace Inspection

- The operator is to take safety measures to avoid all hazards in the work area prior to machine operation.
- Do not operate or raise the platform while on trucks, trailers, railway cars, floating vessels, scaffolds or other equipment unless approved in writing by JLG.
- Do not operate the machine in hazardous environments unless approved for that purpose by JLG.
- Be sure that the ground conditions are able to support the maximum load shown on the decals located on the machine.

Machine Inspection

- Before machine operation, perform inspections and functional checks. Refer to Section 2 of this manual for detailed instructions.
- Do not operate this machine until it has been serviced and maintained according to requirements specified in the Service and Maintenance Manual.
- Be sure the footswitch and all other safety devices are operating properly. Modification of these devices is a safety violation.

WARNING

MODIFICATION OR ALTERATION OF AN AERIAL WORK PLATFORM SHALL BE MADE ONLY WITH WRITTEN PERMISSION FROM THE MANUFACTURER

- Do not operate any machine on which safety or instruction placards or decals are missing or illegible.
- Avoid any buildup of debris on the platform floor. Keep mud, oil, grease, and other slippery substances from footwear and platform floor.

1.3 OPERATION

General

- Do not use the machine for any purpose other than positioning personnel, their tools, and equipment.
 - Never operate a machine that is not working properly. If a malfunction occurs, shut down the machine.
 - Never slam a control switch or lever through neutral to an opposite direction. Always return switch to neutral and stop before moving the switch to the next function. Operate controls with slow and even pressure.
 - Do not allow personnel to tamper with or operate the machine from the ground with personnel in the platform, except in an emergency.
 - Do not carry materials directly on platform railing. Contact JLG for approved material handling accessories.
 - When two or more persons are in the platform, the operator shall be responsible for all machine operations.
 - Always ensure that power tools are properly stowed and never left hanging by their cord from the platform work area.
- Supplies or tools which extend outside the platform are prohibited unless approved by JLG.
 - When driving, always position boom over rear axle in line with the direction of travel. Remember, if boom is over the front axle, steer and drive functions will be reversed.
 - Do not assist a stuck or disabled machine by pushing, pulling, or by using boom functions. Only pull the unit from the tie-down lugs on the chassis.
 - Do not place boom or platform against any structure to steady the platform or to support the structure.
 - Stow boom and shut off all power before leaving machine.

Trip and Fall Hazards

During operation, occupants in the platform must wear a full body harness with a lanyard attached to an authorized lanyard anchorage point. Attach only one (1) lanyard per lanyard anchorage point.

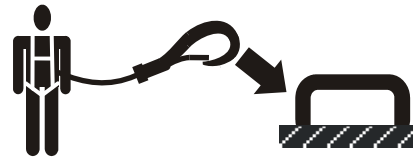

SECTION 1 - SAFETY PRECAUTIONS

- Before operating the machine, make sure all gates are closed and fastened in their proper position.

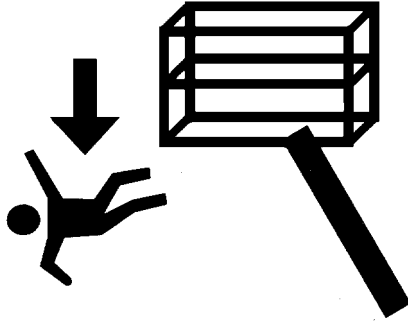

- Keep both feet firmly positioned on the platform floor at all times. Never use ladders, boxes, steps, planks, or similar items on platform to provide additional reach.
- Never use the boom assembly to enter or leave the platform.

- Use extreme caution when entering or leaving platform. Be sure that the boom is fully lowered. It may be necessary to telescope out to position the platform closer to the ground for entry/exit. Face the machine, maintain “three point contact” with the machine, using two hands and one foot or two feet and one hand during entry and exit.

Electrocution Hazards

- This machine is not insulated and does not provide protection from contact or proximity to electrical current.

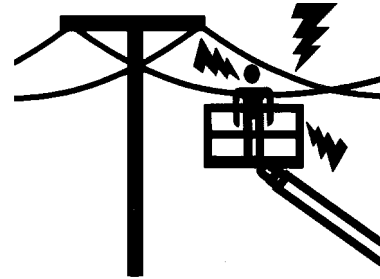

SECTION 1 - SAFETY PRECAUTIONS

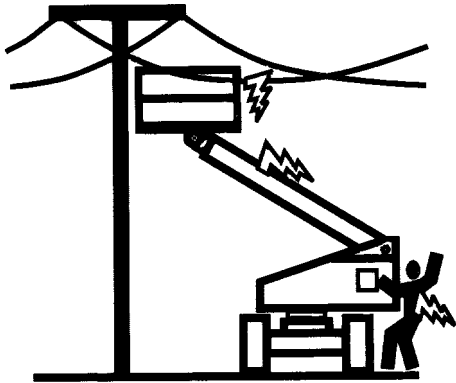

- Maintain distance from electrical lines, apparatus, or any energized (exposed or insulated) parts according to the Minimum Approach Distance (MAD) as shown in Table 1-1.
- Allow for machine movement and electrical line swaying.

Table 1-1. Minimum Approach Distances (M.A.D.)

| Voltage Range (Phase to Phase) | MINIMUM APPROACH DISTANCE in Feet (Meters) |
|-----------------------------------|---|
| 0 to 50 KV | 10 (3) |
| Over 50KV to 200 KV | 15 (5) |
| Over 200 KV to 350 KV | 20 (6) |
| Over 350 KV to 500 KV | 25 (8) |
| Over 500 KV to 750 KV | 35 (11) |
| Over 750 KV to 1000 KV | 45 (14) |

NOTE: *This requirement shall apply except where employer, local or governmental regulations are more stringent.*

- Maintain a clearance of at least 10 ft. (3m) between any part of the machine and its occupants, their tools, and their equipment from any electrical line or apparatus carrying up to 50,000 volts. One foot additional clearance is required for every additional 30,000 volts or less.

SECTION 1 - SAFETY PRECAUTIONS

- The minimum approach distance may be reduced if insulating barriers are installed to prevent contact, and the barriers are rated for the voltage of the line being guarded. These barriers shall not be part of (or attached to) the machine. The minimum approach distance shall be reduced to a distance within the designed working dimensions of the insulating barrier. This determination shall be made by a qualified person in accordance with the employer, local, or governmental requirements for work practices near energized equipment

⚠ DANGER

DO NOT MANEUVER MACHINE OR PERSONNEL INSIDE PROHIBITED ZONE (MAD). ASSUME ALL ELECTRICAL PARTS AND WIRING ARE ENERGIZED UNLESS KNOWN OTHERWISE.

Tipping Hazards

- The user must be familiar with the surface before driving. Do not exceed the allowable sideslope and grade while driving.

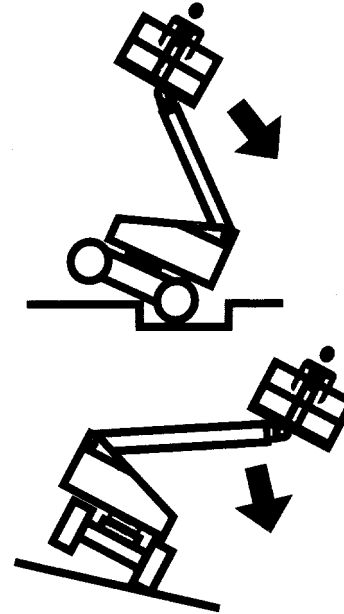

- Do not elevate platform or drive with platform elevated while on a sloping, uneven, or soft surface.
- Before driving on floors, bridges, trucks, and other surfaces, check allowable capacity of the surfaces.
- Never exceed the maximum platform capacity. Distribute loads evenly on platform floor.
- Do not raise the platform or drive from an elevated position unless the machine is on firm, level and smooth surfaces.
- Keep the chassis of the machine at least 2 ft. (0.6m) from holes, bumps, drop-offs, obstructions, debris, concealed holes, and other potential hazards on the floor/surface.
- Do not push or pull any object with the boom.
- Never attempt to use the machine as a crane. Do not tie-off machine to any adjacent structure.
- Do not operate the machine when wind conditions exceed 28 mph (12.5 m/s). Refer to Table 1-2, Beaufort Scale (For Reference Only).
- Do not increase the surface area of the platform or the load. Increase of the area exposed to the wind will decrease stability.
- Do not increase the platform size with unauthorized deck extensions or attachments.

- If boom assembly or platform is in a position that one or more wheels are off the ground, all persons must be removed before attempting to stabilize the machine. Use cranes, forklift trucks, or other appropriate equipment to stabilize machine.

Crushing and Collision Hazards

- Approved head gear must be worn by all operating and ground personnel.
- Check work area for clearances overhead, on sides, and bottom of platform when lifting or lowering platform, and driving.

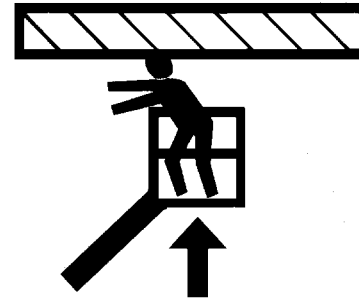

- During operation, keep all body parts inside platform railing.

SECTION 1 - SAFETY PRECAUTIONS

- Use the boom functions, not the drive function, to position the platform close to obstacles.
- Always post a lookout when driving in areas where vision is obstructed.
- Keep non-operating personnel at least 6 ft. (1.8m) away from machine during all driving and swing operations.
- Limit travel speed according to conditions of ground surface, congestion, visibility, slope, location of personnel, and other factors which may cause collision or injury to personnel.
- Be aware of stopping distances in all drive speeds. When driving in high speed, switch to low speed before stopping. Travel grades in low speed only.
- Do not use high speed drive in restricted or close quarters or when driving in reverse.
- Exercise extreme caution at all times to prevent obstacles from striking or interfering with operating controls and persons in the platform.
- Be sure that operators of other overhead and floor level machines are aware of the aerial work platform's presence. Disconnect power to overhead cranes.
- Warn personnel not to work, stand, or walk under a raised boom or platform. Position barricades on floor if necessary.

1.4 TOWING, LIFTING, AND HAULING

- Never allow personnel in platform while towing, lifting, or hauling.
- This machine should not be towed, except in the event of emergency, malfunction, power failure, or loading/unloading. Refer to the Emergency Procedures section of this manual for emergency towing procedures.
- Ensure boom is in the stowed position and the turntable locked prior to towing, lifting or hauling. The platform must be completely empty of tools.
- When lifting machine, lift only at designated areas of the machine. Lift the unit with equipment of adequate capacity.
- Refer to the Machine Operation section of this manual for lifting information.

1.5 ADDITIONAL HAZARDS / SAFETY

- Do not use machine as a ground for welding.
- When performing welding or metal cutting operations, precautions must be taken to protect the chassis from direct exposure to weld and metal cutting spatter.
- Do not refuel the machine with the engine running.
- Battery fluid is highly corrosive. Avoid contact with skin and clothing at all times.
- Charge batteries only in a well ventilated area.

SECTION 1 - SAFETY PRECAUTIONS

NOTICE

DO NOT OPERATE THE MACHINE WHEN WIND CONDITIONS EXCEED 28 MPH (12.5 M/S).

Table 1-2. Beaufort Scale (For Reference Only)

| Beaufort Number | Wind Speed | | Description | Land Conditions |
|-----------------|------------|-----------|-------------------------|--|
| | mph | m/s | | |
| 0 | 0 | 0-0.2 | Calm | Calm. Smoke rises vertically. |
| 1 | 1-3 | 0.3-1.5 | Light air | Wind motion visible in smoke. |
| 2 | 4-7 | 1.6-3.3 | Light breeze | Wind felt on exposed skin. Leaves rustle. |
| 3 | 8-12 | 3.4-5.4 | Gentle breeze | Leaves and smaller twigs in constant motion. |
| 4 | 13-18 | 5.5-7.9 | Moderate breeze | Dust and loose paper raised. Small branches begin to move. |
| 5 | 19-24 | 8.0-10.7 | Fresh breeze | Smaller trees sway. |
| 6 | 25-31 | 10.8-13.8 | Strong breeze | Large branches in motion. Whistling heard in overhead wires. Umbrella use becomes difficult. |
| 7 | 32-38 | 13.9-17.1 | Near Gale/Moderate Gale | Whole trees in motion. Effort needed to walk against the wind. |
| 8 | 39-46 | 17.2-20.7 | Fresh Gale | Twigs broken from trees. Cars veer on road. |
| 9 | 47-54 | 20.8-24.4 | Strong Gale | Light structure damage. |

SECTION 2. USER RESPONSIBILITIES, MACHINE PREPARATION, AND INSPECTION

2.1 PERSONNEL TRAINING

The aerial platform is a personnel handling device; so it is necessary that it be operated and maintained only by trained personnel.

Persons under the influence of drugs or alcohol or who are subject to seizures, dizziness or loss of physical control must not operate this machine.

Operator Training

Operator training must cover:

1. Use and limitations of the controls in the platform and at the ground, emergency controls and safety systems.
2. Control labels, instructions, and warnings on the machine.
3. Rules of the employer and government regulations.
4. Use of approved fall protection device.
5. Enough knowledge of the mechanical operation of the machine to recognize a malfunction or potential malfunction.
6. The safest means to operate the machine where overhead obstructions, other moving equipment, and obstacles, depressions, holes, drop-offs.
7. Means to avoid the hazards of unprotected electrical conductors.
8. Specific job requirements or machine application.

Training Supervision

Training must be done under the supervision of a qualified person in an open area free of obstructions until the trainee has developed the ability to safely control and operate the machine.

Operator Responsibility

The operator must be instructed that he/she has the responsibility and authority to shut down the machine in case of a malfunction or other unsafe condition of either the machine or the job site.

2.2 PREPARATION, INSPECTION, AND MAINTENANCE

The following table covers the periodic machine inspections and maintenance required by JLG Industries, Inc. Consult local regulations for further requirements for aerial work platforms. The frequency of inspections and maintenance must be increased as necessary when the machine is used in a harsh or hostile environment, if the machine is used with increased frequency, or if the machine is used in a severe manner.

NOTICE

JLG INDUSTRIES, INC. RECOGNIZES A FACTORY-QUALIFIED SERVICE TECHNICIAN AS A PERSON WHO HAS SUCCESSFULLY COMPLETED THE JLG SERVICE TRAINING SCHOOL FOR THE SPECIFIC JLG PRODUCT MODEL.

SECTION 2 - USER RESPONSIBILITIES, MACHINE PREPARATION, AND INSPECTION

Table 2-1. Inspection and Maintenance Table

| Type | Frequency | Primary Responsibility | Service Qualification | Reference |
|--|---|------------------------|--|---|
| Pre-Start Inspection | Before using each day; or whenever there's an Operator change. | User or Operator | User or Operator | Operator and Safety Manual |
| Pre-Delivery Inspection (See Note) | Before each sale, lease, or rental delivery. | Owner, Dealer, or User | Qualified JLG Mechanic | Service and Maintenance Manual and applicable JLG inspection form |
| Frequent Inspection (See Note) | In service for 3 months or 150 hours, whichever comes first; or Out of service for a period of more than 3 months; or Purchased used. | Owner, Dealer, or User | Qualified JLG Mechanic | Service and Maintenance Manual and applicable JLG inspection form |
| Annual Machine Inspection (See Note) | Annually, no later than 13 months from the date of prior inspection. | Owner, Dealer, or User | Factory Qualified Service Technician (Recommended) | Service and Maintenance Manual and applicable JLG inspection form |
| Preventative Maintenance | At intervals as specified in the Service and Maintenance Manual. | Owner, Dealer, or User | Qualified JLG Mechanic | Service and Maintenance Manual |
| NOTE: Inspection forms are available from JLG. Use the Service and Maintenance Manual to perform inspections. | | | | |

SECTION 2 - USER RESPONSIBILITIES, MACHINE PREPARATION, AND INSPECTION

Pre-Start Inspection

The Pre-Start Inspection should include each of the following:

1. **Cleanliness** – Check all surfaces for leakage (oil, fuel, or battery fluid) or foreign objects. Report any leakage to the proper maintenance personnel.
2. **Structure** - Inspect the machine structure for dents, damage, weld or parent metal cracks or other discrepancies.

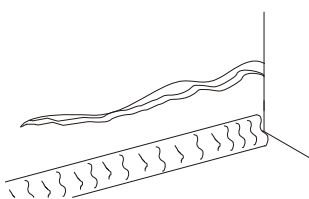

Parent Metal Crack

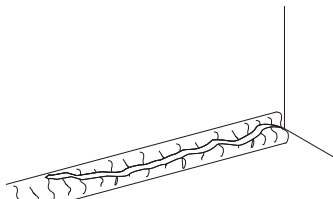

Weld Crack

3. **Decals and Placards** – Check all for cleanliness and legibility. Make sure none of the decals and placards are missing. Make sure all illegible decals and placards are cleaned or replaced.
4. **Operators and Safety Manuals** – Make sure a copy of the Operator and Safety Manual, EMI Safety Manual (Domestic only), and ANSI Manual of Responsibilities

(Domestic only) is enclosed in the weather resistant storage container.

5. **“Walk-Around” Inspection** – Refer to Figure 2-1. thru Figure 2-4.
6. **Battery** – Charge as required.
7. **Fuel** (Combustion Engine Powered Machines) – Add the proper fuel as necessary.
8. **Engine Oil Supply** - Ensure the engine oil level is at the Full mark on the dipstick and the filler cap is secure.
9. **Hydraulic Oil** – Check the hydraulic oil level. Ensure hydraulic oil is added as required.
10. **Function Check** – Once the “Walk-Around” Inspection is complete, perform a functional check of all systems in an area free of overhead and ground level obstructions. Refer to Section 4 for more specific instructions.

⚠ WARNING

IF THE MACHINE DOES NOT OPERATE PROPERLY, TURN OFF THE MACHINE IMMEDIATELY! REPORT THE PROBLEM TO THE PROPER MAINTENANCE PERSONNEL. DO NOT OPERATE THE MACHINE UNTIL IT IS DECLARED SAFE FOR OPERATION.

Function Check

Perform the Function Check as follows:

1. From the ground control panel with no load in the platform:
 - a. Check that all guards protecting the switches or locks are in place;
 - b. Operate all functions and check all limiting and cut-out switches;
 - c. Check auxiliary power (or manual descent);
 - d. Ensure that all machine functions are disabled when the Emergency Stop Button is activated.
2. From the platform control console:
 - a. Ensure that the control console is firmly secured in the proper location;
 - b. Check that all guards protecting the switches or locks are in place;
 - c. Operate all functions and check all limiting and cut-out switches;
 - d. Ensure that all machine functions are disabled when the Emergency Stop Button is pushed in.
3. With the platform in the transport (stowed) position:
 - a. Drive the machine on a grade, not to exceed the rated gradeability, and stop to ensure the brakes hold;
 - b. Check the tilt sensor alarm to ensure proper operation.

SECTION 2 - USER RESPONSIBILITIES, MACHINE PREPARATION, AND INSPECTION

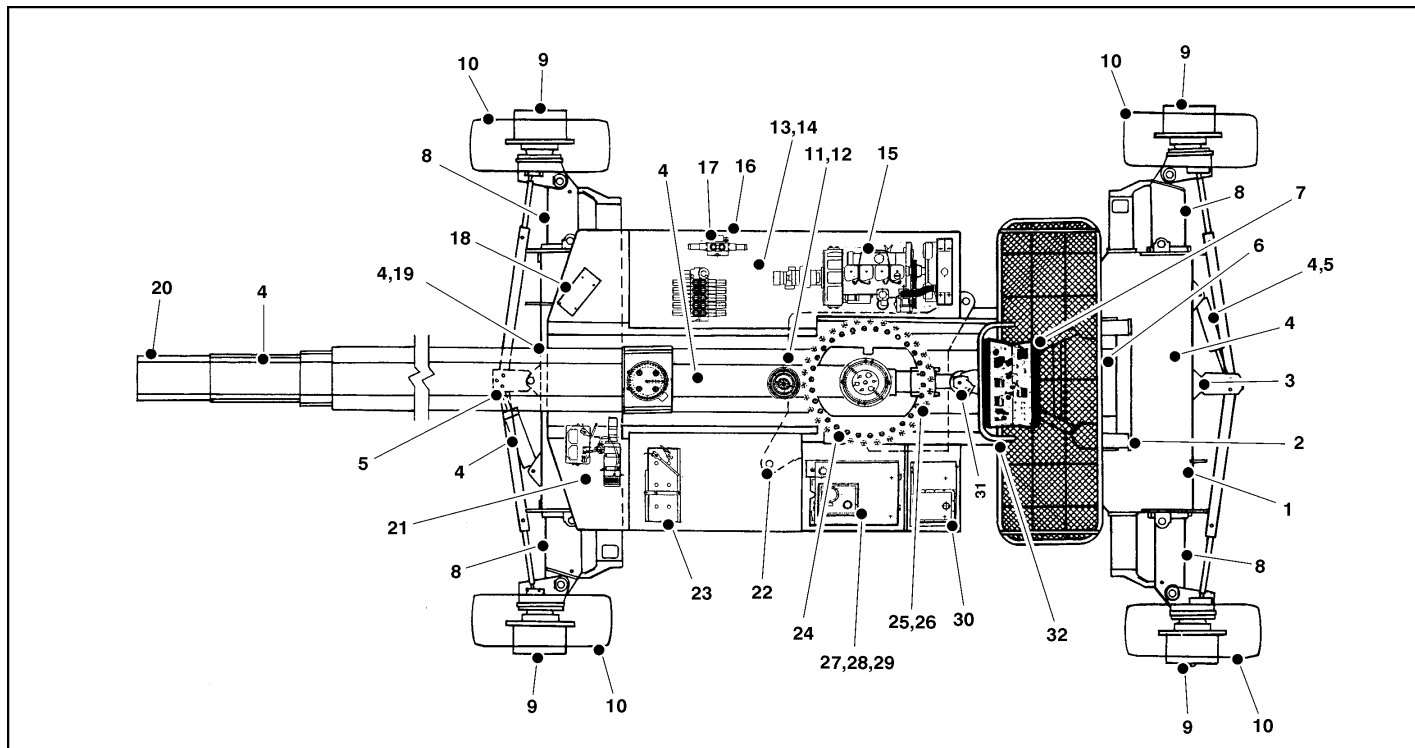

Figure 2-1. Daily Walk-Around Inspection - Sheet 1 of 4

SECTION 2 - USER RESPONSIBILITIES, MACHINE PREPARATION, AND INSPECTION

GENERAL

Begin the "Walk-Around Inspection" at Item 1, as noted on the diagram. Continue to the right (counterclockwise viewed from top) checking each item in sequence for the conditions listed in the following checklist.

WARNING

TO AVOID POSSIBLE INJURY, BE SURE MACHINE POWER IS OFF.

DO NOT OPERATE MACHINE UNTIL ALL MALFUNCTIONS HAVE BEEN CORRECTED.

***INSPECTION NOTE:** On all components, make sure there are no loose or missing parts, that they are securely fastened, and no visible damage, leaks or excessive wear exists in addition to any other criteria mentioned.*

- 1. Rear Frame Deck** - Deck clean and free of grease and oil; deck treads in place and undamaged.
- 2. Platform Access Ladder** - See Inspection Note.
- 3. Axle Jack/Extension Switches** - See Inspection Note; decals in place and legible.
- 4. All Hydraulic Cylinders** - No visible damage; pivot pins and hydraulic hoses undamaged, not leaking.
- 5. Tie Rods and Steering Linkage** - No loose, bent, or missing parts; no visible damage; tie rod ends undamaged.
- 6. Platform Assembly** - See Inspection Note. Foot-switch in good working order; not modified, disabled, or blocked. Gate interlock functioning properly. Intercom properly secured and operating.
- 7. Platform Control Console** - Switches and controllers properly secured; no loose or missing parts; information and operating placards are in place and legible; controllers and switches return to neutral; control markings legible. Capacity indicator properly secured; no visible damage; operating properly.
- 8. Extendable Axle** - See Inspection Note. Power track and hydraulic hoses secure and undamaged; no evidence of leakage.

Figure 2-2. Daily Walk-Around Inspection - Sheet 2 of 4

SECTION 2 - USER RESPONSIBILITIES, MACHINE PREPARATION, AND INSPECTION

9. **Drive Hub, Drive Motor and Drive Brake** - See Inspection Note.
10. **Steer/Drive Wheel/Tire Assembly** - Properly secured; no loose or missing lug nuts; no visible damage.
11. **Hose and Cable Guards/Clamps** - See Inspection Note.
12. **Power Track** - See Inspection Note.
13. **Muffler and Exhaust System** - See Inspection Note.
14. **Engine Air Filter Assembly** - See Inspection Note; element clean.
15. **Engine Oil Supply** - Full mark on dipstick; filler cap secure.
16. **Cowling and Latches** - All cowling, doors, and latches in working condition; See Inspection Note.
17. **Control Valve Compartment** - See Inspection Note.
18. **Ground Controls** - Switches and controllers operable; no visible damage; placards secure and legible.
19. **Axle Jack/Extension Switches** - See Inspection Note; decals in place and legible.
20. **Main Boom Pivot Pin** - See Inspection Note.
21. **Manual Descent Valves and Pump** - Valve handles and pump handle properly secured. Instruction placards in place and legible.
22. **Turntable Lock** - Operable; See Inspection Note.
23. **Battery** - Proper electrolyte level; cables tight; no visible damage or corrosion.
24. **Turntable Bearing and Pinion** - See Inspection Note. No evidence of loose bolts or looseness between bearing and structure.

Figure 2-3. Daily Walk-Around Inspection - Sheet 3 of 4

SECTION 2 - USER RESPONSIBILITIES, MACHINE PREPARATION, AND INSPECTION

- 25. **Boom Limit Switches** - Properly secured; no damage to cams or switches; cams free from excess dirt and grease.
- 26. **Boom Sections** - No visible damage; wear pads secure; boom chain adjusting nuts secure and undamaged; lift and telescope cylinders - rod end shafts and barrel end shafts properly secured; no evidence of leakage; evidence of proper lubrication.
- 27. **Hydraulic Oil Supply** - Recommended oil level. (Check level with cold oil, systems shut down, machine in stowed position.) Cap secure and in place.
- 28. **Oil Filter Housing** - See Inspection Note.
- 29. **Hydraulic Oil Breather** - Element in place; not clogged; no visible signs of overflow.
- 30. **Fuel Supply** - Fuel filler cap secure. Tank - See Inspection Note.
- 31. **Platform Pivot and Slave Cylinder Attach Pins** - See Inspection Note.
- 32. **Frame** - No visible damage; no loose or missing hardware (top and underside).

Figure 2-4. Daily Walk-Around Inspection - Sheet 4 of 4

2.3 DAILY FUNCTIONAL CHECK

A functional check of all systems should be performed, under no load, once the walk-around inspection is complete, in an area free of overhead and ground level obstructions. First, using the ground controls, check all functions controlled by the ground controls. Next, using the platform controls, check all functions controlled by the platform controls.

WARNING

TO AVOID SERIOUS INJURY, DO NOT OPERATE MACHINE IF ANY CONTROLLERS OR TOGGLE SWITCHES CONTROLLING PLATFORM MOVEMENTS DO NOT RETURN TO THE OFF POSITION WHEN RELEASED.

TO AVOID A COLLISION AND INJURY IF PLATFORM DOES NOT STOP WHEN A CONTROL SWITCH OR CONTROLLER IS RELEASED, REMOVE FOOT FROM FOOTSWITCH OR USE EMERGENCY STOP TO STOP MACHINE.

Axle Extension System

WARNING

WHEN RAISING FRAME TO OPERATE AXLE EXTENSION SYSTEM, RAISE ONLY ONE JACK CYLINDER AT A TIME. DO NOT RAISE BOTH CYLINDERS AT THE SAME TIME, AS THIS WILL CAUSE THE MACHINE TO BECOME UNSTABLE.

1. From ground controls, activate the machine hydraulic system.
2. Position JACK cylinder switch on axle to DOWN and hold until wheels rise from the ground.
3. Remove lock pin from left tie rod.
4. Position EXTEND/RETRACT switch for front axle to extend until the left axle is fully extended. White tape on axle beam must be completely exposed to indicate full extension of axle. Install left tie rod lock pin.
5. Remove lock pin from right tie rod.
6. Position EXTEND/RETRACT switch for front axle to extend until the right axle is fully extended. White tape on axle beam must be completely exposed to indicate full extension of axle. Install right tie rod lock pin.
7. Position JACK cylinder switch to UP to lower the machine wheels.
8. Check AXLES SET indicator light to ensure it is illuminated.
9. Repeat steps (2) through (8) for rear axle.

Axle Retraction System

1. From ground controls, activate the machine hydraulic system.
2. Position JACK cylinder switch on axle to DOWN and hold until wheels rise from the ground.
3. Remove lock pin from left tie rod.
4. Position EXTEND/RETRACT switch for front axle to retract until the left axle is fully retracted. Install left tie rod lock pin.
5. Remove lock pin from right tie rod.
6. Position EXTEND/RETRACT switch for front axle to retract until the right axle is fully retracted. Install right tie rod lock pin.
7. Position JACK cylinder switch to UP to lower the machine wheels.
8. Repeat steps (2) through (7) for rear axle.

Function Cut-Outs and Restrictions

1. Platform Gate Interlock

The engine will not start unless the platform gate is closed and latched.

2. Swing Cut-Out

With axles retracted, boom will only swing between drive tires.

3. Tower Telescope Cut-Out

With axles retracted, tower boom will not telescope. Only main boom will telescope.

WARNING

WITH AXLES RETRACTED AND MAIN BOOM EXTENDED, DO NOT ATTEMPT TO RAISE AND EXTEND AXLE THAT MAIN BOOM IS EXTENDED OVER. RETRACT MAIN BOOM BEFORE ATTEMPTING TO RAISE AND EXTEND AXLE.

SECTION 2 - USER RESPONSIBILITIES, MACHINE PREPARATION, AND INSPECTION

4. Tower Boom Horizontal Cut-Out

With the tower boom above horizontal, HIGH DRIVE and 2 SPEED are cut out. In addition, with tower boom above horizontal, selecting DRIVE or MAIN LIFT cuts out HIGH ENGINE on TOWER LIFT and TOWER TELESCOPE functions, DRIVE function automatically goes to CREEP mode, and HIGH ENGINE is cut out except as noted in step (9).

5. Axles/Axles Jack Cut-Out

To retract axles or operate axle jacks, ground controls must be selected, booms must be below horizontal and between drive wheels.

6. 5° Tilt Cut-Out

When machine is on a 5° slope, 2 speed is cut out, regardless of tower boom position. In addition, if tower boom is above horizontal with machine on a 5° slope, drive function is cut out and all other functions automatically go into creep mode.

7. Tower Boom Cut-Outs

Tower telescope and main lift are cut out unless tower lift is fully up. Tower lift is cut out unless tower telescope is fully in and main lift is fully down.

8. Main Boom Lift Cut-Out

When main boom lift is operating, lift speed automatically goes into the creep mode 18° before each end of the lift cylinder stroke.

9. Tower Lift and Tower Telescope Cut-Outs

When activating Tower Lift UP or DOWN or Tower Telescope IN or OUT, high engine is activated at full controller stroke. This feature can be turned off at platform controls using HIGH ENGINE switch.

10. Auxiliary Power

When auxiliary power is activated, the CREEP function does not work. In addition, if engine is running and auxiliary power is activated, the engine will shut off. This prevents the operator from increasing function speeds.

Tower Boom Sequence

1. Place the machine on level ground and with the tower boom in the stowed position. Identify the hydraulic valve adjacent to the tower lift cylinder at the bottom end (rear) of the tower base boom.

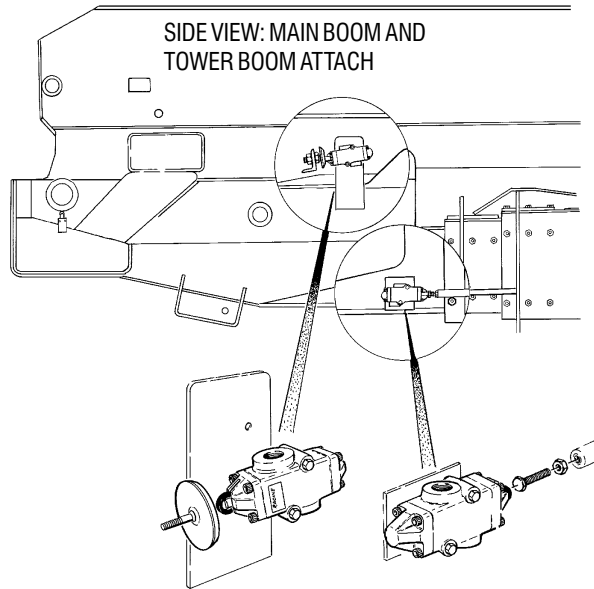

2. Visually check the two valves in the turntable to ensure the plungers are fully extended

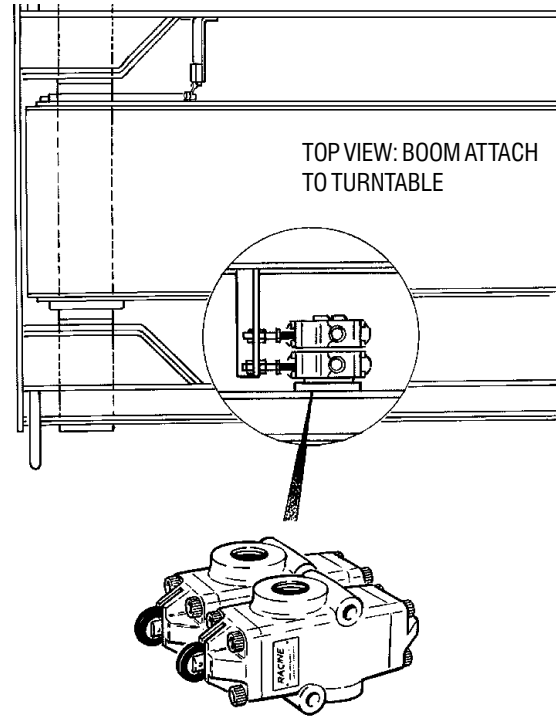

SECTION 2 - USER RESPONSIBILITIES, MACHINE PREPARATION, AND INSPECTION

NOTE: *If the plunger is not fully extended, contact a qualified service technician to further evaluate this condition before operating the machine.*

3. Try to extend the tower boom assembly.

NOTE: *The boom should not extend and the red check light in the ground console panel should illuminate. If the light does not come on, contact a qualified service technician to further evaluate this condition before operating the machine.*

4. Try to raise the main boom assembly.

NOTE: *The boom should not raise and the red check light in the ground console panel should illuminate. If the light does not come on, contact a qualified service technician to further evaluate this condition before operating the machine.*

5. Attempt to lower the tower base boom with the tower fly boom extended.

NOTE: *The tower base boom should not lower and the red check light in the ground console should illuminate. If the light does not come on, contact a qualified service technician to further evaluate this condition before operating the machine.*

6. Fully retract the tower boom. Lift the main boom several feet. Attempt to lower the tower boom.

NOTE: *Tower Lift down should not work and the red check light in the ground console panel should illuminate. If the light does not come on, contact a qualified service technician to further evaluate this condition before operating the machine.*

Tower Boom Lift and Swing Systems

Raise and lower tower boom, then swing tower boom to LEFT and RIGHT as swing cut-out will allow. Cycle functions several times. Check for smooth elevation and swing motion.

Tower Boom Telescope System

Telescope tower boom IN and OUT several cycles at various degrees of elevation. Check for smooth telescope operation.

Main Boom Lift System

Raise and lower main boom several times. Check for smooth operation.

Main Boom Telescope System

Telescope main boom IN and OUT several cycles at various degrees of elevation. Check for smooth telescope operation.

Platform Leveling Systems

Check that platform automatic self-leveling system functions properly during raising and lowering of boom.

Check platform level adjustment system for proper operation.

Platform Rotator

Check rotator for smooth operation and assure platform will rotate 90 degrees in both directions from centerline of boom.

Drive System

Drive machine forward and reverse; check for proper operation.

Steer System

Steer machine left and right; check for proper operation.

Footswitch

NOTICE

FOOTSWITCH MUST BE ADJUSTED SO THAT FUNCTIONS WILL OPERATE WHEN PEDAL IS APPROXIMATELY AT ITS CENTER OF TRAVEL. IF SWITCH OPERATES WITHIN LAST 1/4" OF TRAVEL, TOP OR BOTTOM, IT SHOULD BE ADJUSTED.

1. Activate hydraulic system. Activate footswitch. Operate TOWER BOOM TELESCOPE and hold controller. Remove foot from footswitch, motion should stop. If it does not, shut down machine and contact a qualified service technician.
2. With hydraulic system and footswitch activated, operate MAIN BOOM LIFT and hold control. Remove foot from footswitch, motion should stop. If it does not, shut down machine and contact a qualified service technician.
3. With hydraulic power shut down, place foot on footswitch. Attempt to start engine. Engine should not attempt to start when footswitch is engaged. If starter engages or engine turns over, shut down machine and contact a qualified service technician.

Auxiliary Power

Operate each function control switch or controller (e.g. TELE, LIFT, SWING) to assure that they function in both directions using auxiliary power instead of engine power.

Ground Controls

Place GROUND/PLATFORM SELECT switch to GROUND. Start engine. Platform controls should not operate.

SECTION 2 - USER RESPONSIBILITIES, MACHINE PREPARATION, AND INSPECTION

 **NOTES:**

| | |
|---|---|
| <hr/> <hr/> <hr/> <hr/> <hr/> <hr/> <hr/> <hr/> <hr/> <hr/> <hr/> <hr/> <hr/> <hr/> <hr/> <hr/> <hr/> <hr/> <hr/> <hr/> <hr/> <hr/> <hr/> | <hr/> <hr/> <hr/> <hr/> <hr/> <hr/> <hr/> <hr/> <hr/> <hr/> <hr/> <hr/> <hr/> <hr/> <hr/> <hr/> <hr/> <hr/> <hr/> <hr/> <hr/> <hr/> <hr/> |
|---|---|

SECTION 3. MACHINE CONTROLS AND INDICATORS

3.1 GENERAL

NOTICE

THE MANUFACTURER HAS NO DIRECT CONTROL OVER MACHINE APPLICATION AND OPERATION. THE USER AND OPERATOR ARE RESPONSIBLE FOR CONFORMING WITH GOOD SAFETY PRACTICES.

This section provides the necessary information needed to understand control functions.

3.2 CONTROLS AND INDICATORS

The Model 150HAX is equipped with control panels that use symbols and words to indicate control functions. On some machines, the control panels may use symbols only.

NOTE: *The Ground Control Station consists of two parts, the stationary Ground Control Panel, and the movable Ground Control Remote Box. The remote box can be removed from the ground control station, and is attached to the machine by a 50 foot (15 m) cable. This will allow the operator to control platform movement away from the machine to gain a better view of the platform location.*

Ground Control Panel

⚠ WARNING

DO NOT OPERATE FROM GROUND CONTROL STATION WITH PERSONNEL IN THE PLATFORM EXCEPT IN AN EMERGENCY.

PERFORM AS MANY PRE-OPERATIONAL CHECKS AND INSPECTIONS FROM THE GROUND CONTROL STATION AS POSSIBLE.

NOTE: *When the machine is shut down the master switch must be positioned to OFF to prevent draining the battery and burning ignition points.*

1. Master Switch (Prior to S/N 46291)

A two-position key operated switch furnishes electrical power to the IGNITION ON relays, the EMERGENCY STOP switch and to the PLATFORM/GROUND SELECT SWITCH when in the ON position.

SECTION 3 - MACHINE CONTROLS AND INDICATORS

2. Platform/Ground Select Switch

A three-position, center-off PLATFORM/GROUND SELECT SWITCH supplies operating power to the controls on the platform control console, when positioned to PLATFORM. With the switch in GROUND position, power is shut off to the controls at the platform station, and only the controls on the ground control panel and remote box are operable.

NOTE: *With the PLATFORM/GROUND SELECT SWITCH in the center position, power is shut off to controls at both operating stations.*

3. Axles Set Indicator Light

The AXLES SET indicator light is illuminated when the axles are fully extended and locked in place.

4. High Engine Circuit Breaker

A rocker-type push button reset 30 Amp circuit breaker returns interrupted power to the high engine function when depressed.

5. Hourmeter

An HOURMETER records the engine operating time.

6. Voltmeter

With the ignition switch in the ON position, and before starting the engine, the VOLTMETER indicates the condition of the battery. With the engine running, the VOLTMETER indicates output voltage of the alternator.

Normal reading for the voltmeter will be 12-14 volts with a properly charged or charging battery.

7. Oil Pressure Gauge

An OIL PRESSURE gauge provides an indication of the engine lubrication system pressure.

8. Water Temperature Gauge

A WATER TEMPERATURE gauge provides an indication of the coolant temperature within the engine.

9. Tower Proximity Switch Check Light

Indicates that the ground control tower lift, main lift or telescope function switch is being selected with the tower or main boom outside of the allowable operating range. Refer to Daily Functional Check, Tower Boom Sequence in Section 2.

SECTION 3 - MACHINE CONTROLS AND INDICATORS

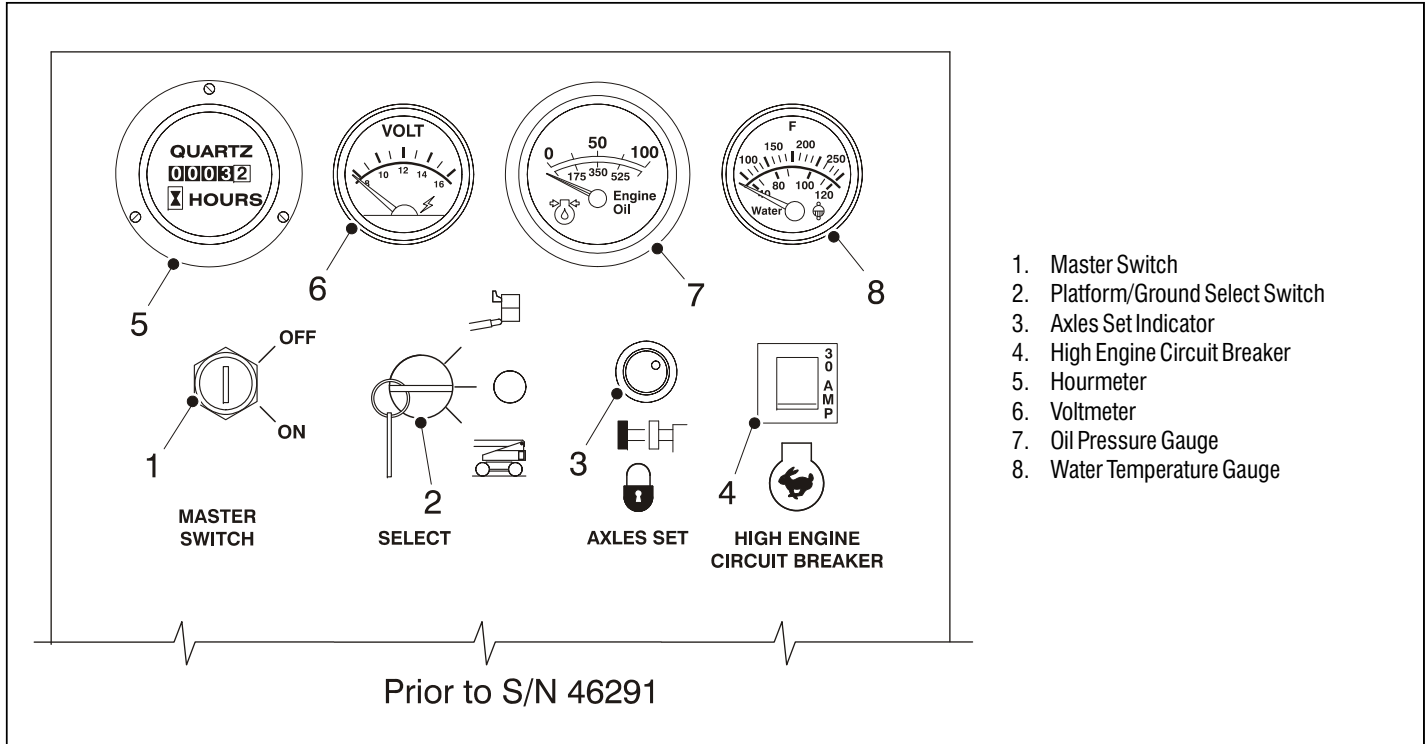
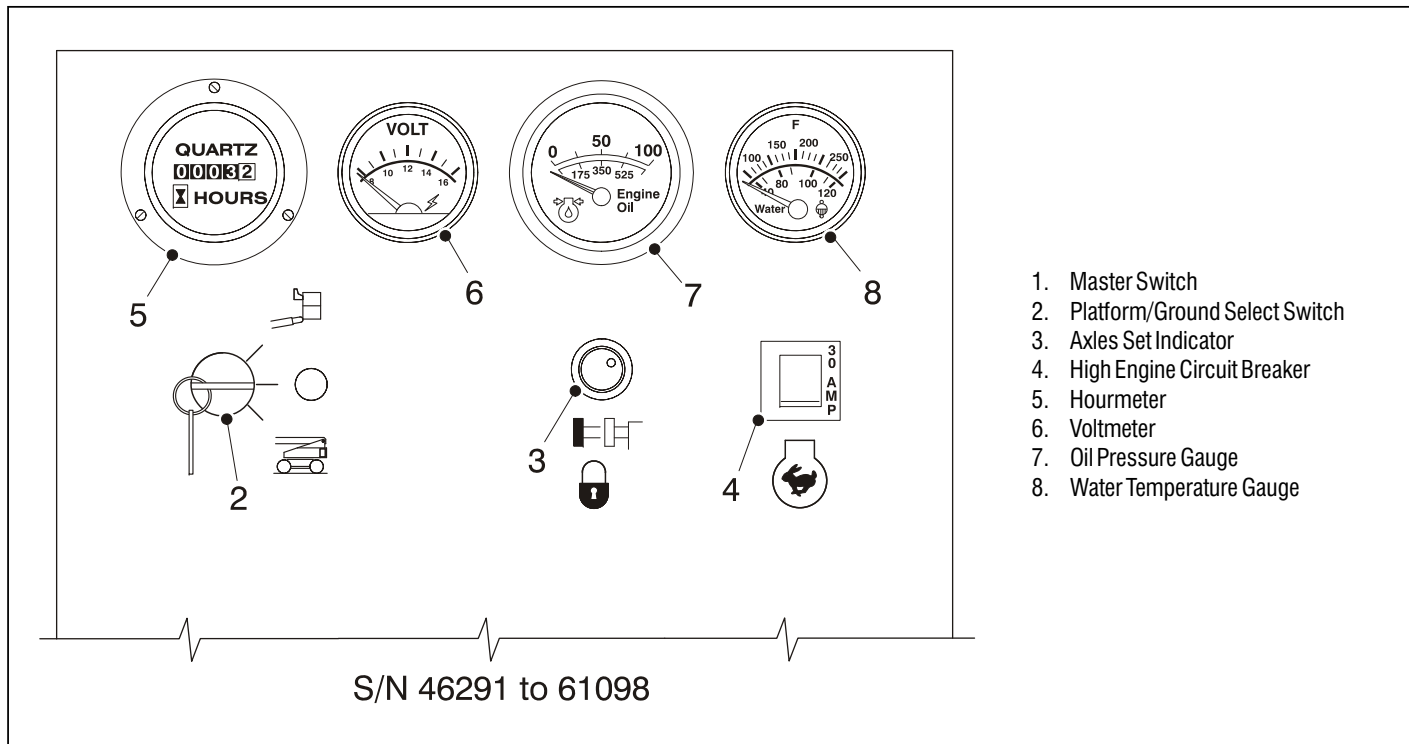

Figure 3-1. Ground Control Panel - Sheet 1 of 3

SECTION 3 - MACHINE CONTROLS AND INDICATORS



1. Master Switch
2. Platform/Ground Select Switch
3. Axles Set Indicator
4. High Engine Circuit Breaker
5. Hourmeter
6. Voltmeter
7. Oil Pressure Gauge
8. Water Temperature Gauge

Figure 3-2. Ground Control Panel - Sheet 2 of 3

SECTION 3 - MACHINE CONTROLS AND INDICATORS

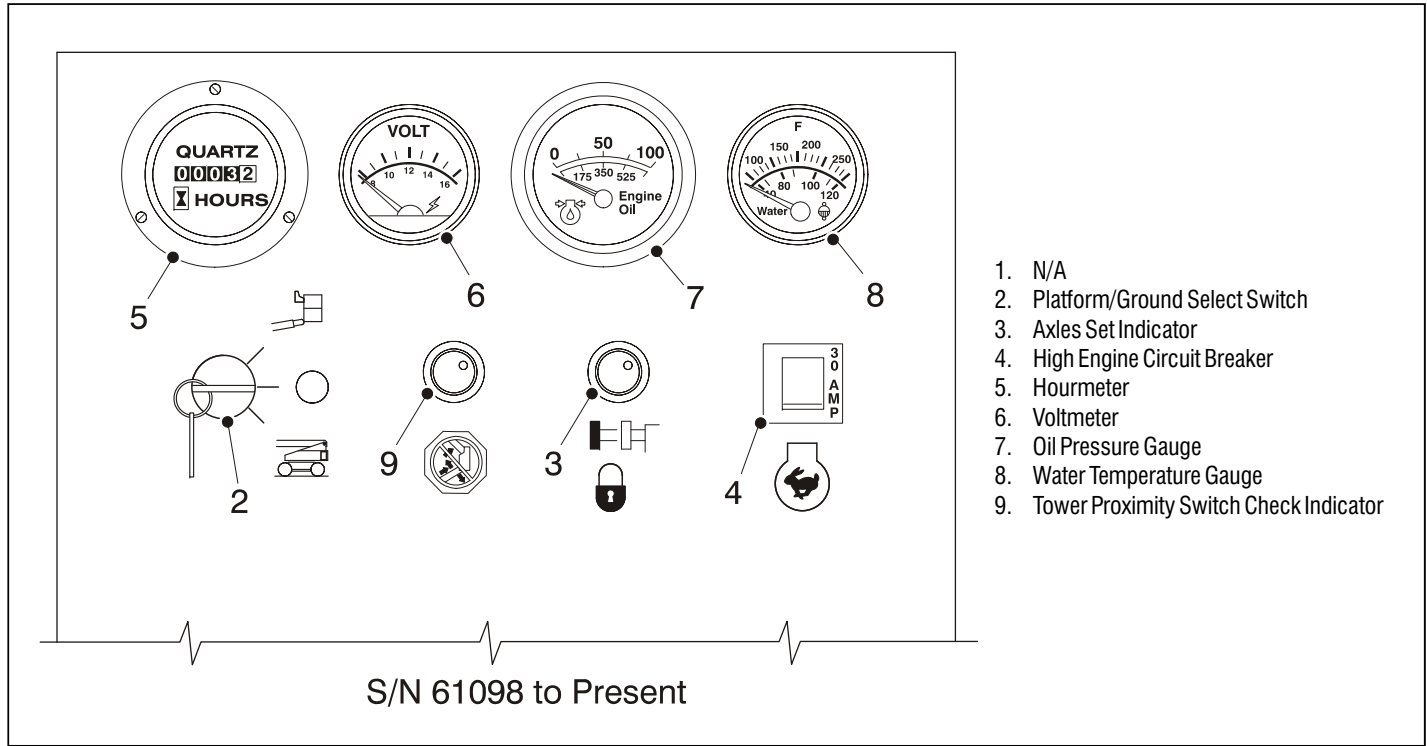

1. N/A
2. Platform/Ground Select Switch
3. Axles Set Indicator
4. High Engine Circuit Breaker
5. Hourmeter
6. Voltmeter
7. Oil Pressure Gauge
8. Water Temperature Gauge
9. Tower Proximity Switch Check Indicator

Figure 3-3. Ground Control Panel - Sheet 3 of 3

SECTION 3 - MACHINE CONTROLS AND INDICATORS

Ground Control Remote Box

NOTE: *If equipped, the Function Enable switch must be held down in order to operate Main Boom Telescope, Tower Lift, Swing, Main Lift, Platform Level Override, and Platform Rotate functions.*

1. Auxiliary Power Switch

A toggle-type AUXILIARY POWER control switch, energizes the electrically operated auxiliary hydraulic pump, when actuated. (Switch must be held ON for duration of auxiliary pump use.)

- a. The auxiliary pump functions to provide sufficient oil flow to operate the basic machine system should the main pump or engine fail during operation. The auxiliary pump enables the boom lift, telescope, swing and platform level functions to be operated.
- b. It should be noted that functions will operate at a slower than normal rate because of the lower gpm delivered.

NOTE: *When operating on auxiliary power, do not operate more than one function at a time. Simultaneous operation can overload the 12-volt auxiliary pump motor.*

- c. Position PLATFORM/GROUND SELECT SWITCH to GROUND.
- d. Position MASTER SWITCH to ON.
- e. Operate appropriate switch for desired function and direction.
- f. Position AUXILIARY POWER SWITCH to ON and hold.
- g. Release both AUXILIARY POWER SWITCH TO ON AND HOLD AND SELECTED FUNCTION SWITCH.
- h. Position MASTER SWITCH to OFF

WARNING

TO AVOID SERIOUS INJURY, DO NOT OPERATE MACHINE IF ANY CONTROLLERS OR TOGGLE SWITCHES CONTROLLING PLATFORM MOVEMENT DO NOT RETURN TO THE OFF POSITION WHEN RELEASED.

2. Platform Rotate Switch

A three-position ROTATE control switch permits rotation of the platform when positioned LEFT or RIGHT.

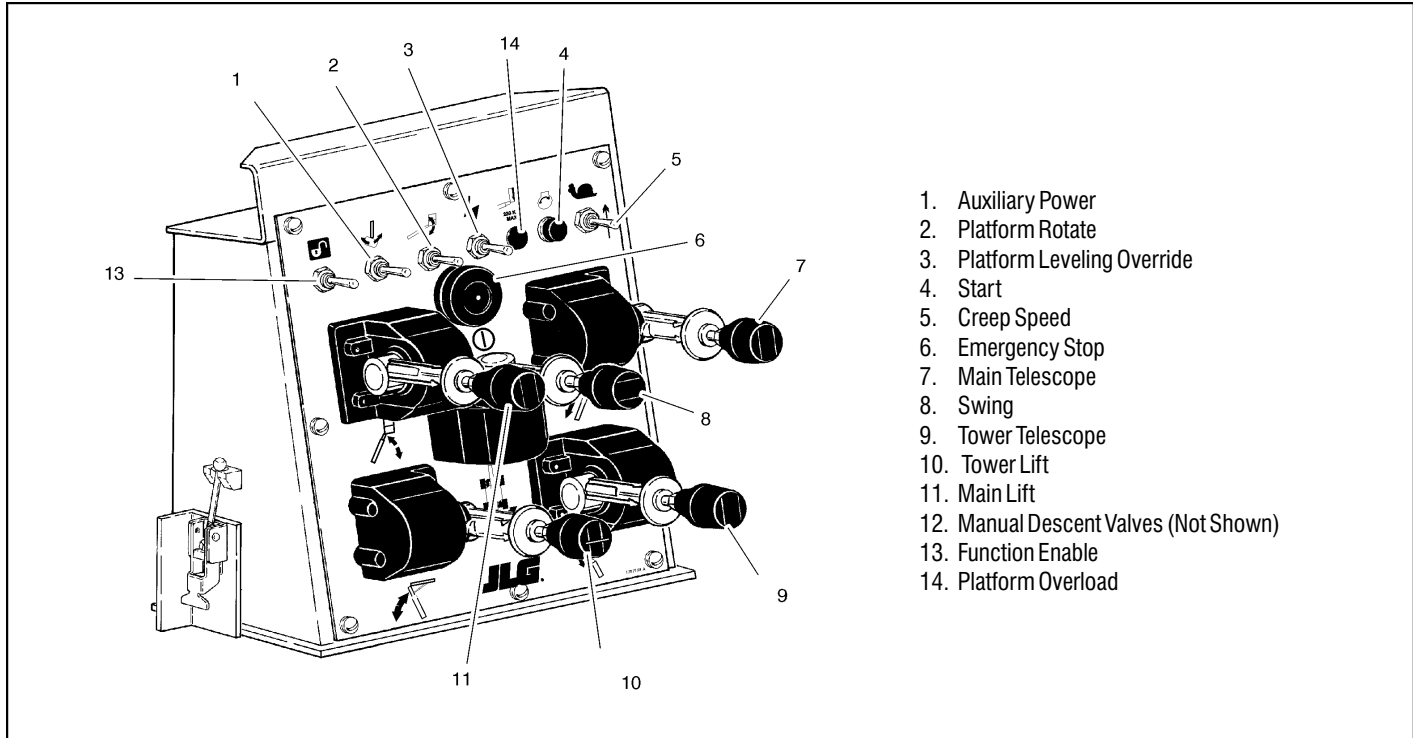

Figure 3-4. Ground Control Remote Box

SECTION 3 - MACHINE CONTROLS AND INDICATORS

WARNING

ONLY USE THE PLATFORM LEVELING OVERRIDE FUNCTION FOR SLIGHT LEVELING OF THE PLATFORM. INCORRECT USE COULD CAUSE THE LOAD/OCCUPANT TO SHIFT OR FALL. FAILURE TO DO SO COULD RESULT IN DEATH OR SERIOUS INJURY.

3. Platform Leveling Override

A three position switch allows the operator to adjust the automatic self leveling system. This switch is used to adjust platform level in situations such as ascending/descending a grade.

4. Start Switch

A momentary contact, push button type switch that, when depressed, supplies electrical power to the starter solenoid when the MASTER SWITCH and IGNITION/EMERGENCY STOP switches are in the ON position.

5. Creep Speed Switch

The Creep Speed Switch allows the operator to select a lower speed for machine functions when positioned to on.

6. Emergency Stop Button

The EMERGENCY STOP button supplies electrical power from the IGNITION ON relays to the START button when the button is pulled out and the MASTER SWITCH is in the ON position. When depressed, the button shuts off electrical power to the machine.

7. Main Telescope Controller

The MAIN TELESCOPE controller provides extension and retraction of the main boom when positioned to IN or OUT.

8. Swing Controller

The SWING controller provides 360° continuous turntable rotation. To activate SWING, position and hold controller to LEFT or RIGHT.

NOTE: *Controllers and switches controlling platform movement automatically return to the center off position when released.*

9. Tower Telescope Controller

The TOWER TELESCOPE controller provides extension and retraction of the tower boom when positioned to IN or OUT.

SECTION 3 - MACHINE CONTROLS AND INDICATORS

10. Tower Lift Controller

The TOWER LIFT controller provides raising and lowering of the tower boom when positioned to UP or DOWN.

11. Main Lift Controller

The MAIN LIFT controller provides raising and lowering of the main boom when positioned to UP or DOWN.

12. Manual Descent Valves (Not Shown)

The manual descent valves are located on the left front of the machine turntable. The manual descent valves should be used, in the event of a total power failure, to lower the work platform in the event of an emergency. The valves permit the use of gravity to retract the tower boom and lower the main boom. Refer to Section 6 for a complete description of the manual descent systems, their application and their operation.

13. Function Enable

If equipped, the enable switch must be held "DOWN" to enable all boom controls when the engine is running.

14. Platform Overload (If equipped)

Indicates the platform has been overloaded.

Platform Control Station

WARNING

ONLY USE THE PLATFORM LEVELING OVERRIDE FUNCTION FOR SLIGHT LEVELING OF THE PLATFORM. INCORRECT USE COULD CAUSE THE LOAD/OCCUPANT TO SHIFT OR FALL. FAILURE TO DO SO COULD RESULT IN DEATH OR SERIOUS INJURY.

1. Platform Leveling Override

A three position switch allows the operator to adjust the automatic self leveling system. This switch is used to adjust platform level in situations such as ascending/descending a grade.

2. Drive/Steer Controller

The DRIVE/STEER controller operates two functions: Drive and Rear Steer. Positioning the controller handle forward operates Drive Forward, and positioning the handle to the rear operates Drive Reverse. The rocker switch on top of the controller handle operates the steer function for the rear wheels. Depressing the left side of the rocker switch will cause the machine to steer to the left, and depressing the right side of the rocker switch will cause the machine to steer to the right.

CAUTION

WHEN DRIVING FORWARD AND OPERATING THE REAR STEER WHEELS, THE REAR WHEELS WILL TURN IN THE OPPOSITE DIRECTION OF MACHINE TRAVEL, I.E., DEPRESSING THE LEFT SIDE OF THE ROCKER SWITCH WILL CAUSE THE WHEELS TO TURN TO THE RIGHT.

3. Tower Telescope Controller

The TOWER TELESCOPE controller provides extension and retracting of the tower boom when positioned to IN or OUT.

4. Start Button

The START button is a momentary contact, push button type switch. With the MASTER SWITCH positioned to ON and the START button depressed, electrical power is supplied to the starter solenoid.

5. Choke/Glow Plug Switch (If Equipped)

The optional CHOKE/GLOW PLUG switch is used to assist cold engine starting. For diesel engines, the switch activates glow plugs in the engine to warm the diesel fuel for easier starting. On gasoline engines, the switch activates the choke to deliver a richer fuel mixture for easier starting.

SECTION 3 - MACHINE CONTROLS AND INDICATORS

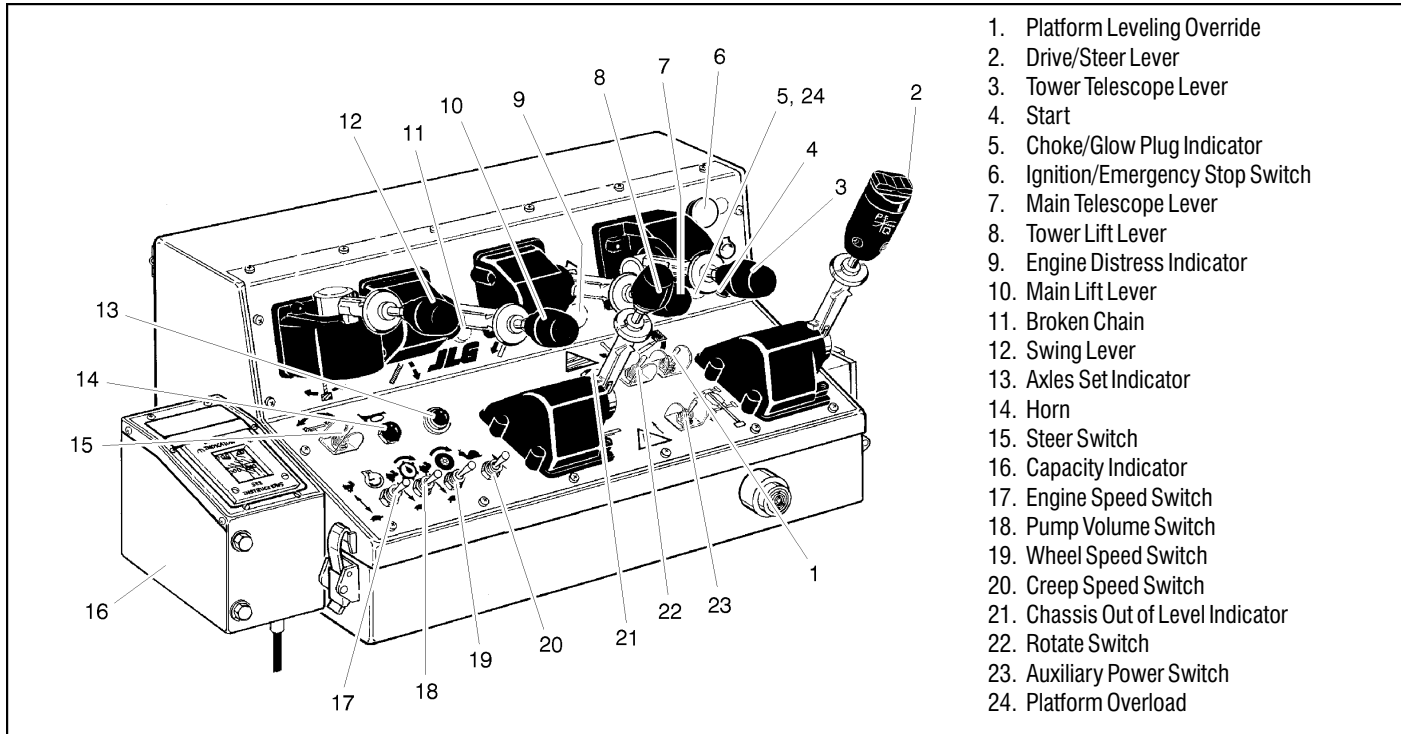

Figure 3-5. Platform Control Station

SECTION 3 - MACHINE CONTROLS AND INDICATORS

6. Ignition/Emergency Stop Button

The IGNITION/EMERGENCY STOP button, when pulled out, supplies power to the start button. When depressed, the button shuts off machine power in case of an emergency.

7. Main Telescope Controller

The MAIN TELESCOPE controller provides extension and retraction of the main boom when positioned to IN or OUT.

8. Tower Lift Controller

The TOWER LIFT controller provides raising and lowering of the tower boom when positioned to UP or DOWN.

9. Engine Distress Indicator (If Equipped)

The red ENGINE DISTRESS indicator illuminates to warn the operator of high engine coolant temperature or low oil pressure.

10. Main Lift Controller

The MAIN LIFT controller provides raising and lowering of the main boom when positioned to UP or DOWN.

11. Broken Chain (CE)

The red BROKEN CHAIN indicator light will illuminate to warn the operator of a broken fly extend chain in the main boom or a broken fly retract chain in the main boom.

12. Swing Controller

The SWING controller provides 360° continuous boom rotation when positioned to LEFT or RIGHT.

13. Axles Set Indicator (Green)

The green AXLES SET indicator light illuminates when the axles are fully extended and locked in place.

14. Warning Horn

The HORN push button switch, when pressed, supplies electrical power to activate the warning horn. The horn is also activated by the Tilt Alarm switch when the chassis is on a severe slope (over 5°).

SECTION 3 - MACHINE CONTROLS AND INDICATORS

15. Steer Switch

The STEER control controls operation of the front steer wheels of the machine. When the steer switch is positioned to RIGHT or LEFT, the machine will steer to the corresponding direction.

16. Capacity Indicator

The capacity indicator gauge is located in a box attached to the left side of the platform control console. This gauge indicates the maximum platform capacity allowable at any given boom angle and extension based on the color stripe visible on top of the fly boom at the point where the fly boom enters the mid boom.

17. Engine Speed Switch

The two-position ENGINE SPEED control switch allows the operator to select higher engine speeds when positioned to HIGH under certain conditions. With the main boom below horizontal, HIGH ENGINE SPEED will operate with DRIVE, TOWER TELESCOPE, and TOWER LIFT. With the main boom above horizontal and the appropriate function control handle at the end of its travel, HIGH ENGINE SPEED will operate with TOWER LIFT and TOWER TELESCOPE.

18. Pump Volume Switch

The two-position PUMP VOLUME control switch allows the operator to select high pump flow, providing additional speed to machine functions when positioned to HIGH. The PUMP VOLUME switch will operate in HIGH position only when the main boom is below horizontal.

19. Wheel Speed Switch

The two-position WHEEL SPEED control switch allows the operator to select high wheel motor speed when positioned to HIGH with the main boom below horizontal.

NOTE: *Machine function speeds automatically go into the CREEP mode when boom is raised above horizontal.*

20. Creep Speed Switch

The CREEP speed control switch allows the operator to select a lower speed for machine functions when positioned to ON.

SECTION 3 - MACHINE CONTROLS AND INDICATORS

21. Chassis Out of Level (Tilt Alarm) Warning Light (Red)

A warning light on the control console that lights when the chassis is on a severe slope.

CAUTION

IF TILT ALARM IS ON WHEN BOOM IS RAISED OR EXTENDED, RETRACT BOOM AND LOWER PLATFORM TO NEAR GROUND LEVEL, THEN REPOSITION MACHINE SO THAT IT IS LEVEL BEFORE EXTENDING OR RAISING BOOM.

TOGGLE SWITCHES OR CONTROL LEVERS CONTROLLING PLATFORM MOVEMENT AUTOMATICALLY RETURN TO THE CENTER OFF POSITION WHEN RELEASED.

WARNING

TO AVOID SERIOUS INJURY, DO NOT OPERATE MACHINE IF ANY TOGGLE SWITCHES OR CONTROLLERS CONTROLLING PLATFORM MOVEMENT DO NOT RETURN TO THE CENTER OFF POSITION WHEN RELEASED.

22. Platform Rotate Switch.

The PLATFORM ROTATE control switch allows the operator to rotate the basket to the left or right when positioned to the desired direction.

23. Auxiliary Power.

The AUXILIARY POWER control switch energizes the electrically-operated hydraulic pump when actuated. Switch must be held ON for duration of auxiliary pump use.

The auxiliary pump functions to provide sufficient oil flow to operate the basic machine system should the main pump or engine fail. The auxiliary pump will operate tower boom lift, main boom lift, main telescope, and swing.

It should be noted that the functions will operate at a slower than normal rate because of the lower gpm (lpm) delivered.

NOTICE

WHEN OPERATING ON AUXILIARY POWER, DO NOT OPERATE MORE THAN ONE FUNCTION AT THE SAME TIME. SIMULTANEOUS OPERATION CAN OVERLOAD THE AUXILIARY PUMP MOTOR.

NOTE: *The main function of the auxiliary power control is to lower the platform in the event of primary power failure. Determine the reason for primary power failure and have the problem corrected by a qualified service technician.*

SECTION 3 - MACHINE CONTROLS AND INDICATORS

Auxiliary power is primarily intended for platform lowering in the event of primary power failure. However, auxiliary power may be used for platform positioning when operating in close quarters in the following sequence:

- a. Position PLATFORM/GROUND switch to PLATFORM.
- b. Position IGNITION/EMERGENCY STOP switch to ON.
- c. Depress and hold footswitch.
- d. Operate appropriate control switch or lever for desired function and hold.
- e. Position AUXILIARY POWER switch to ON and hold.
- f. Release AUXILIARY POWER switch, selected control switch or lever, and footswitch.
- g. Position IGNITION/EMERGENCY STOP switch to OFF.

24. Platform Overload (If equipped)

Indicates the platform has been overloaded.

25. Intercom (Not Shown)

The machine is equipped with an intercom system that permits the operator in the platform to communicate with personnel on the ground. The platform intercom is located to the right of the platform control console, and is attached to the platform rail. The ground intercom is located on the right front side of the machine turntable.

26. Platform Receptacle (Not Shown)

A dual 110 Volt receptacle is located on the right side of the platform control console. The receptacle is connected either to a plug located on the right front of the machine turntable that can be connected to 110 Volt power, or, if equipped, to a 110 Volt generator on the machine. The purpose of the platform receptacle is to permit the operator to operate power tools in the platform.

SECTION 3 - MACHINE CONTROLS AND INDICATORS

NOTE: For engine starting, the footswitch must be in the released (up) position. Footswitch must be actuated in order for controls to function.

NOTE: The platform gate must be latched in order to operate the machine. A platform gate limit switch disconnects power to the ignition switch when the gate is not latched.

27. Footswitch (Not Shown)

A safety feature makes it necessary to depress the footswitch to allow operation of the controls.

WARNING

TO AVOID SERIOUS INJURY, DO NOT REMOVE, MODIFY OR DISABLE THE FOOTSWITCH BY BLOCKING OR ANY OTHER MEANS.

NOTICE

FOOTSWITCH MUST BE ADJUSTED SO THAT FUNCTIONS WILL OPERATE WHEN PEDAL IS APPROXIMATELY AT ITS CENTER OF TRAVEL. IF SWITCH OPERATES WITHIN LAST 1/4" OF TRAVEL, TOP OR BOTTOM, IT SHOULD BE ADJUSTED.

SECTION 4. MACHINE OPERATION

4.1 DESCRIPTION

This machine is a self-propelled hydraulic lift equipped with a work platform on the end of an elevating and rotating boom.

The JLG Lift has a primary operator Control Station in the platform. From this Control Station, the operator can drive and steer the machine in both forward and reverse directions. The operator can raise, lower, extend or retract the tower boom; raise, lower, extend or retract the main boom; swing the boom to the left or right; and rotate the platform around the boom tip. Standard boom swing is 360° continuous left and right of the stowed position. The machine has a Ground Control Station which will override the Platform Control Station. Ground Controls operate boom lift, telescope, swing, and rotate and are to be used only in an emergency to lower the platform to the ground should the operator in the platform be unable to do so.

4.2 OPERATING CHARACTERISTICS AND LIMITATIONS

Capacities

The boom can be raised above horizontal with or without any load in the platform if:

- 1. Machine is positioned on a smooth, firm and level surface.
- 2. Load is within manufacturer's rated design capacity.
- 3. All machine systems are functioning properly.
- 4. Proper tire pressure exists in the tires.
- 5. Machine is as originally equipped from JLG.

Stability

Machine stability is based on two (2) positions which are called FORWARD stability and BACKWARD stability. The machine's position of least FORWARD stability is shown in Figure 4-1., Position of Least Forward Stability, and it's position of least BACKWARD stability is shown in Figure 4-2., Position of Least Backward Stability.

SECTION 4 - MACHINE OPERATION

⚠ WARNING

TO AVOID FORWARD OR BACKWARD UPSET, DO NOT OVERLOAD MACHINE OR OPERATE ON AN OUT-OF-LEVEL SURFACE.

4.3 ENGINE OPERATION

NOTE: Initial starting should always be performed from the Ground Control Station.

Starting Procedure

1. Check engine oil. If necessary, add oil in accordance with the Engine Manufacturer's Manual.
2. Check fuel level. Add fuel if necessary.
3. Check that air cleaner components are in place and securely fastened.

⚠ CAUTION

IF ENGINE FAILS TO START PROMPTLY, DO NOT CRANK FOR AN EXTENDED PERIOD. SHOULD ENGINE FAIL TO START ONCE AGAIN, ALLOW STARTER TO "COOL OFF" FOR 2 TO 3 MINUTES. IF ENGINE FAILS AFTER SEVERAL ATTEMPTS REFER TO ENGINE MAINTENANCE MANUAL.

4. Place ENGINE SPEED control switch on platform control console to LOW position.

NOTE: Footswitch must be in released (pedal up) position before starter will operate. If starter operates with footswitch in the depressed position, DO NOT OPERATE MACHINE.

NOTE: The platform gate must be latched in order to operate the machine. A platform gate limit switch disconnects power to the ignition switch when the gate is not latched.

5. Turn key of MASTER SWITCH to ON. Position PLATFORM/GROUND SELECT switch to GROUND or PLATFORM, then depress and hold START button until engine starts.

⚠ CAUTION

ALLOW ENGINE TO WARM-UP FOR A FEW MINUTES AT LOW SPEED BEFORE APPLYING ANY LOAD.

6. After engine has had sufficient time to warm up, position ENGINE SPEED/HIGH ENGINE control switch to desired setting.

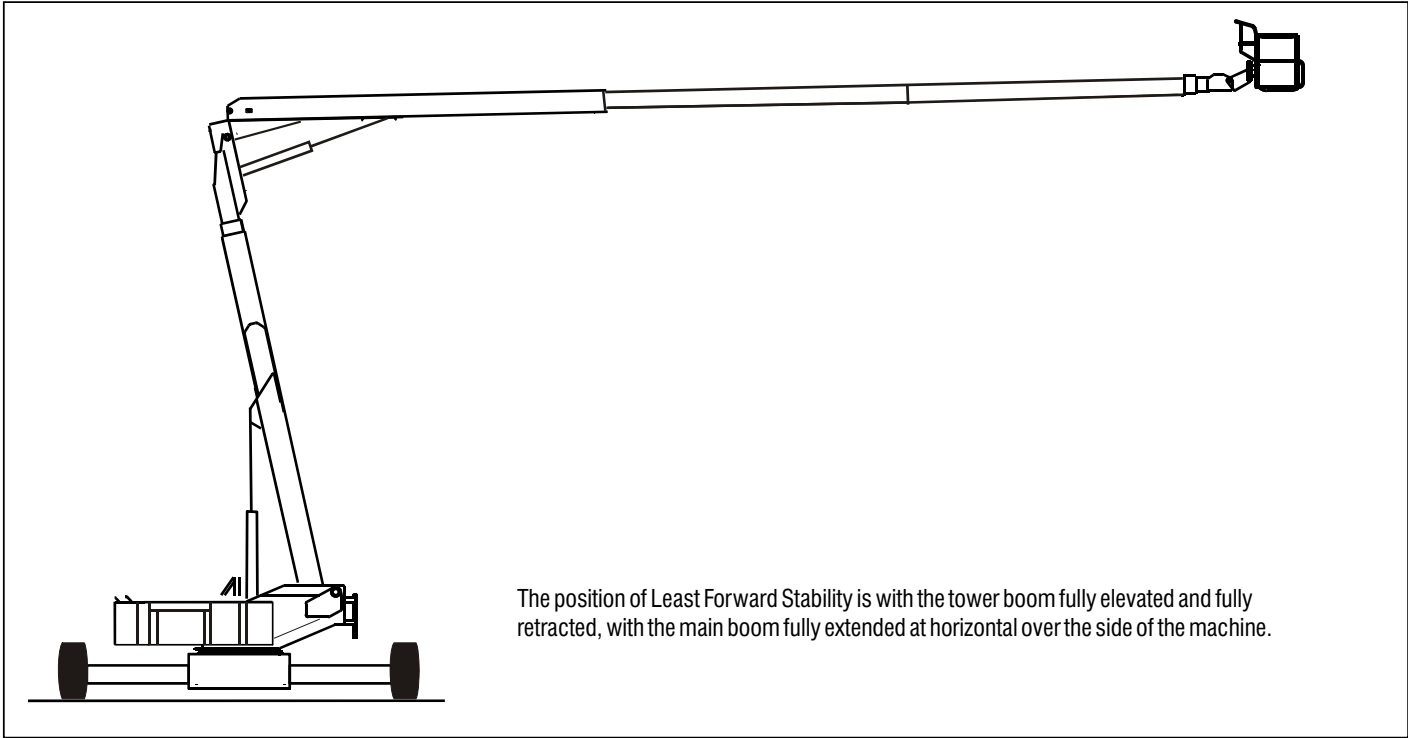

Figure 4-1. Position of Least Forward Stability

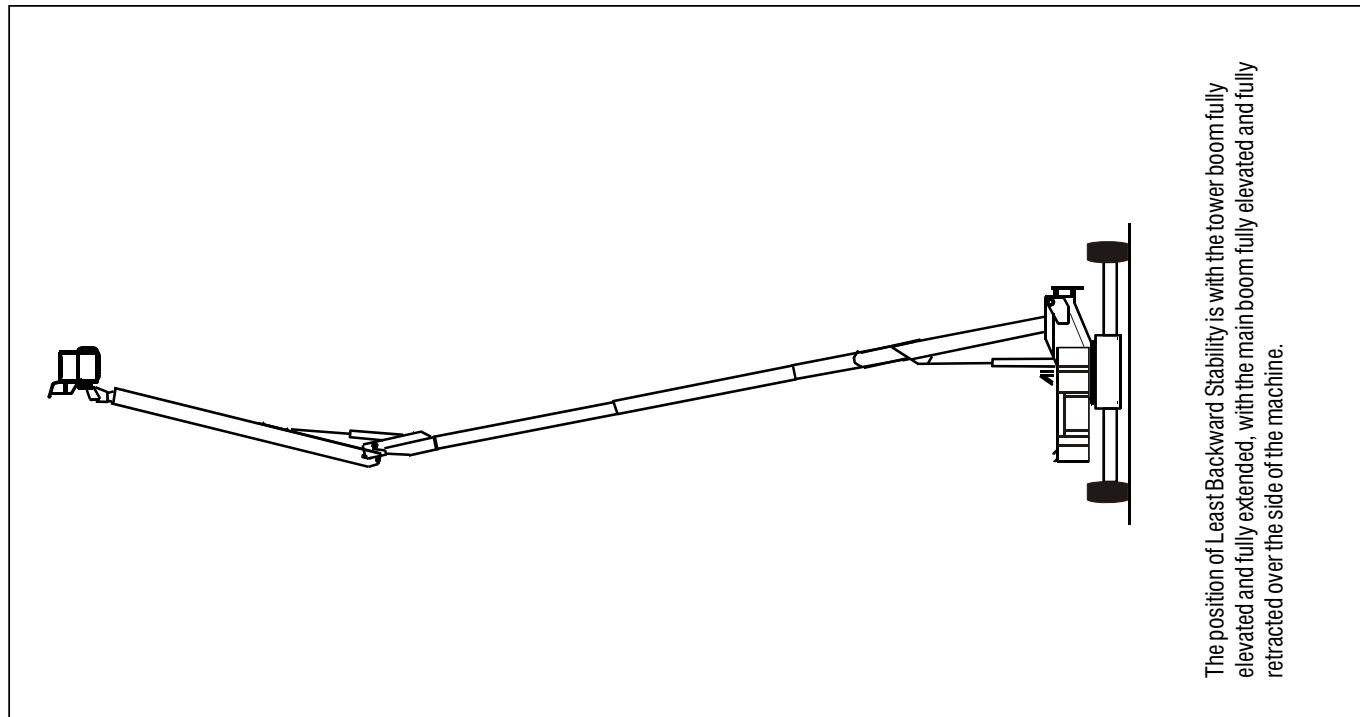

Figure 4-2. Position of Least Backward Stability

Shutdown Procedure

CAUTION

IF AN ENGINE MALFUNCTION NECESSITATES UNSCHEDULED SHUTDOWN, DETERMINE AND CORRECT CAUSE BEFORE RESUMING ANY OPERATION.

1. Position ENGINE SPEED/HIGH ENGINE control switch on platform control console to LOW.
2. Remove all load and allow engine to operate at low speed setting for 3 to 5 minutes; this allows for further reduction of internal engine temperature.
3. Position MASTER SWITCH to OFF position.

NOTE: Refer to Engine Manufacturer's manual for detailed information.

4.4 TRAVELING (DRIVING)

WARNING

DO NOT DRIVE WITH BOOMS EXTENDED OR ABOVE HORIZONTAL EXCEPT ON A SMOOTH, FIRM AND LEVEL SURFACE.

TO AVOID LOSS OF TRAVEL CONTROL OR UPSET ON GRADES AND SIDESLOPES, DO NOT DRIVE MACHINE ON GRADES OR SIDESLOPES EXCEEDING THOSE SPECIFIED ON CAUTION PLACARD AT PLATFORM.

ASSURE THAT TURNTABLE LOCK IS ENGAGED BEFORE BEGINNING ANY EXTENDED TRAVELING. AVOID ANY TERRAIN FEATURES WHICH COULD CAUSE THE MACHINE TO UPSET.

TRAVEL GRADES IN "LOW" DRIVE SPEED, "LOW" WHEEL MOTOR SPEED AND "HIGH" ENGINE SPEED ONLY. USE EXTREME CAUTION WHEN DRIVING IN REVERSE AND AT ALL TIMES WHEN DRIVING WITH PLATFORM ELEVATED AND ESPECIALLY WHEN DRIVING WITH ANY PART OF MACHINE WITHIN 6 FEET (1.8 METERS) OF AN OBSTRUCTION. DO NOT USE DRIVE TO MANEUVER PLATFORM CLOSE TO AN OBSTRUCTION...USE ONE OF THE BOOM FUNCTIONS.

CAUTION

BEFORE DRIVING, MAKE SURE BOOMS ARE POSITIONED OVER REAR AXLE.

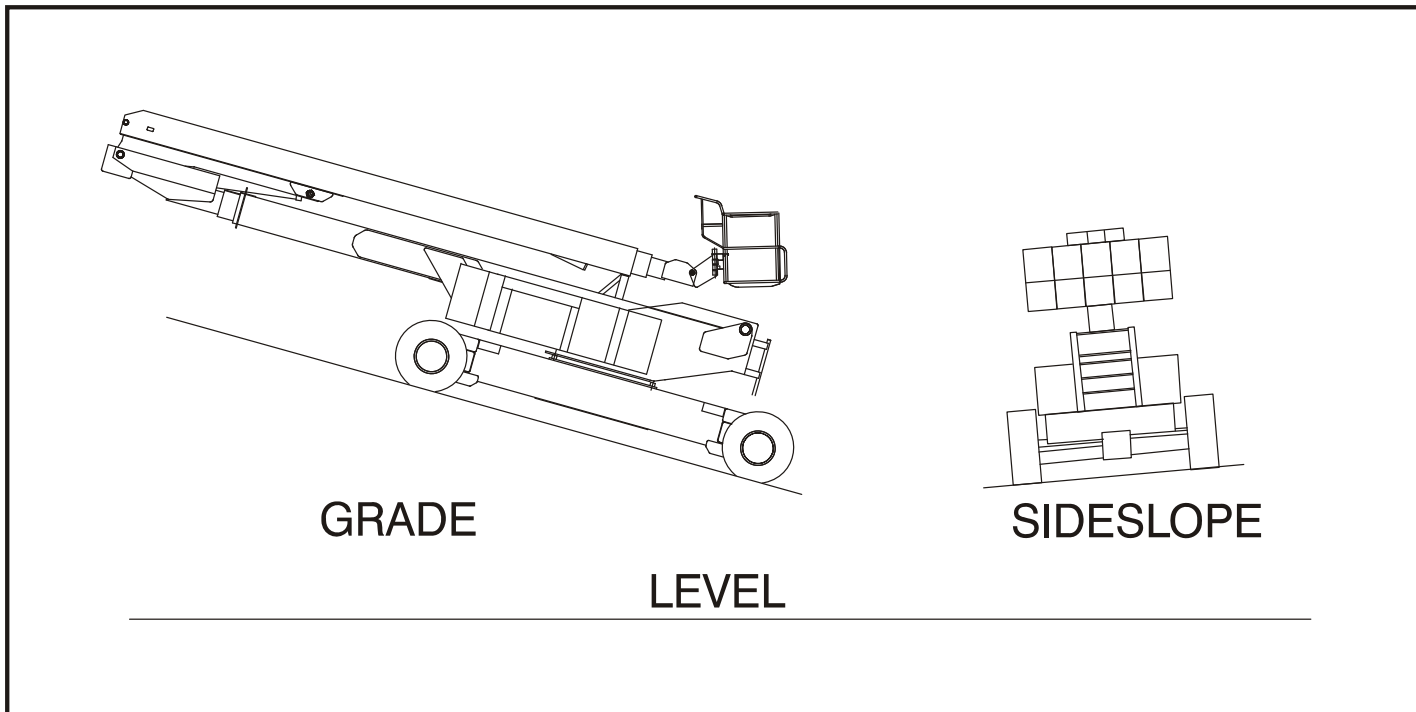

Figure 4-3. Grade and Sideslope

Traveling Forward and Reverse

1. Depress footswitch and position DRIVE controller/control lever to FORWARD and hold for the duration of forward travel desired.
2. Depress footswitch and position DRIVE controller/control lever to REVERSE and hold for the duration of reverse travel desired.
3. To steer machine using front wheels, position STEER control switch to RIGHT for traveling right or LEFT for traveling left.
4. To steer machine using rear steer wheels, position STEER rocker switch on top of DRIVE controller to RIGHT for traveling right or LEFT for traveling left.
5. To obtain maximum travel speed, position the DRIVE controller/control lever to FAST and position the ENGINE SPEED, PUMP VOLUME and WHEEL SPEED switches to HIGH.
6. Prior to stopping the machine, position ENGINE SPEED, DRIVE SPEED and WHEEL SPEED switches to LOW.
7. For going up grades, position WHEEL SPEED switch to LOW and HIGH ENGINE switch to HIGH.

4.5 STEERING

To steer machine using front steer wheels, position STEER control switch on platform control console to RIGHT for traveling right, or to LEFT for traveling left. To steer machine using rear steer wheels, position STEER rocker switch on top of DRIVE controller to RIGHT for traveling right, or to LEFT for traveling left.

4.6 PARKING AND STOWING

Park and stow machine as follows:

1. Park machine in travel position; platform lowered over rear, all access panels and doors closed and secured, ignition off, lock turntable.
2. Check that brakes hold machine in position.
3. Chock wheels front and rear.
4. Turn MASTER SWITCH to OFF and remove key.

4.7 PLATFORM

Loading From Ground Level

1. Position chassis on a smooth, firm and level surface.
2. If total load (personnel, tools and supplies) is 500 lbs. (227 kg) or less for single capacity use, distribute load uniformly on platform floor and proceed to work position. If total load (personnel, tools and supplies) is 1,000 lbs. (454 kg) or less for dual capacity use and machine is within proper capacity location, distribute load uniformly on platform floor and proceed to work position

Loading From Positions Above Ground Level

Before loading weight to platform above ground level:

1. Determine what the total weight will be after additional weight is loaded (personnel, tools and supplies).
2. If total weight in platform will be 500 lbs. (227 kg) or less for a single capacity machine, proceed with adding weight. If total weight in platform is 1,000 lbs. (454 kg) or less for dual capacity machine and machine is within proper capacity location, distribute load uniformly on platform floor and proceed to work position

Platform Level Adjustment

1. Leveling UP. To raise platform, position LEVEL control switch to UP and hold until platform is level.
2. Leveling DOWN. To lower platform, position LEVEL control switch to DOWN and hold until platform is level.

WARNING

ONLY USE THE PLATFORM LEVELING OVERRIDE FUNCTION FOR SLIGHT LEVELING OF THE PLATFORM. INCORRECT USE COULD CAUSE THE LOAD/OCCUPANT TO SHIFT OR FALL. FAILURE TO DO SO COULD RESULT IN DEATH OR SERIOUS INJURY.

Platform Rotation

1. To rotate platform to the left, position ROTATE control switch to LEFT and hold until desired platform position is reached.
2. To rotate platform to the right, position ROTATE control switch to RIGHT and hold until desired platform position is reached.

4.8 BOOM

WARNING

A RED TILT ALARM WARNING LIGHT IS LOCATED ON THE CONTROL CONSOLE WHICH LIGHTS WHEN THE CHASSIS IS ON A SEVERE SLOPE (5° OR GREATER). DO NOT SWING, RAISE TOWER BOOM OR EXTEND OR RAISE MAIN BOOM ABOVE HORIZONTAL WHEN LIGHT IS LIT.

DO NOT DEPEND ON TILT ALARM AS A LEVEL INDICATOR FOR THE CHASSIS. TILT ALARM INDICATES CHASSIS IS ON A SEVERE SLOPE (5° OR GREATER). CHASSIS MUST BE LEVEL BEFORE SWINGING, RAISING TOWER BOOM OR EXTENDING OR RAISING MAIN BOOM ABOVE HORIZONTAL.

TRAVELING WITH MAIN BOOM RETRACTED AND BELOW HORIZONTAL IS PERMITTED ON GRADES AND SIDE SLOPES SPECIFIED IN SECTION 6.

TO AVOID UPSET IF RED TILT ALARM WARNING LIGHT ILLUMINATES WHEN MAIN BOOM IS EXTENDED OR RAISED ABOVE HORIZONTAL, RETRACT AND LOWER PLATFORM TO NEAR GROUND LEVEL. THEN REPOSITION MACHINE SO THAT CHASSIS IS LEVEL BEFORE EXTENDING OR RAISING MAIN BOOM.

TO AVOID SERIOUS INJURY, DO NOT OPERATE MACHINERY IF ANY CONTROL LEVERS OR TOGGLE SWITCHES CONTROLLING PLATFORM MOVEMENT DO NOT RETURN TO THE OFF POSITION WHEN RELEASED.

TO AVOID A COLLISION AND INJURY IF PLATFORM DOES NOT STOP WHEN A CONTROL SWITCH OR LEVER IS RELEASED, REMOVE FOOT FROM FOOTSWITCH OR USE EMERGENCY STOP TO STOP MACHINE.

Swinging the Boom

NOTICE

ASSURE THAT TURNABLE LOCK IS DISENGAGED BEFORE STARTING ANY SWING OPERATION.

1. To swing boom, position SWING controller to RIGHT or LEFT for direction desired.

NOTE: *With axles retracted, boom will only swing between wheels. Axles must be fully extended and locked to obtain 360° rotation.*

Raising and Lowering the Boom

To raise or lower boom, position LIFT controller (standard controls) or control lever (hydraulic controls) to UP or DOWN and hold until desired height is reached.

Telescoping the Tower Boom

To extend or retract tower boom, ensure tower boom is fully elevated, then position TOWER TELESCOPE controller to IN or OUT and hold until tower boom reaches desired position.

Telescoping the Main Boom

To extend or retract main boom, position MAIN BOOM TELESCOPE controller to IN or OUT and hold until platform reaches desired position.

4.9 SHUT-DOWN AND PARK

1. Drive machine to a reasonably well protected area.
2. Position HIGH ENGINE speed control switch on Platform Console to LOW.
3. Assure main boom is fully retracted and lowered over rear (Drive) axle; all access panels and doors closed and secured.
4. Remove all load and allow engine to operate 3 to 5 minutes at LOW setting to permit faster reduction of engine internal temperatures.
5. Turn MASTER SWITCH at Ground Control Station to OFF and remove key.
6. Cover Platform Control Console to protect instruction placards, warning decals and operating controls from hostile environment.

4.10 TIE DOWN AND LIFTING

Tie Down

When transporting machine, boom must be in the stowed mode with turntable lock pin engaged and machine securely tied down to truck or trailer deck. A lifting/tie down eye is provided at each of the four corners of the machine frame. In addition, another four tie down eyes are provided on the machine frame, one behind each of the four drive/steer wheels.

Lifting

If it becomes necessary to lift the machine using an overhead or mobile crane, it is very important that the lifting devices are attached only to the designated lifting eyes, and that the turntable lock pin is engaged.

A lifting/tie down eye is provided at each of the four corners of the machine frame. When lifting the machine, each of the four chains or slings used for lifting the machine must be adjusted individually so the machine remains level when elevated.

NOTICE

SECURE TURNTABLE WITH TURNTABLE LOCK BEFORE TRAVELING LONG DISTANCES OR HAULING MACHINE ON TRUCK/TRAILER.

4.11 TOWING

The machine is not equipped with a tow package. Refer to Section 5 for emergency towing procedures.

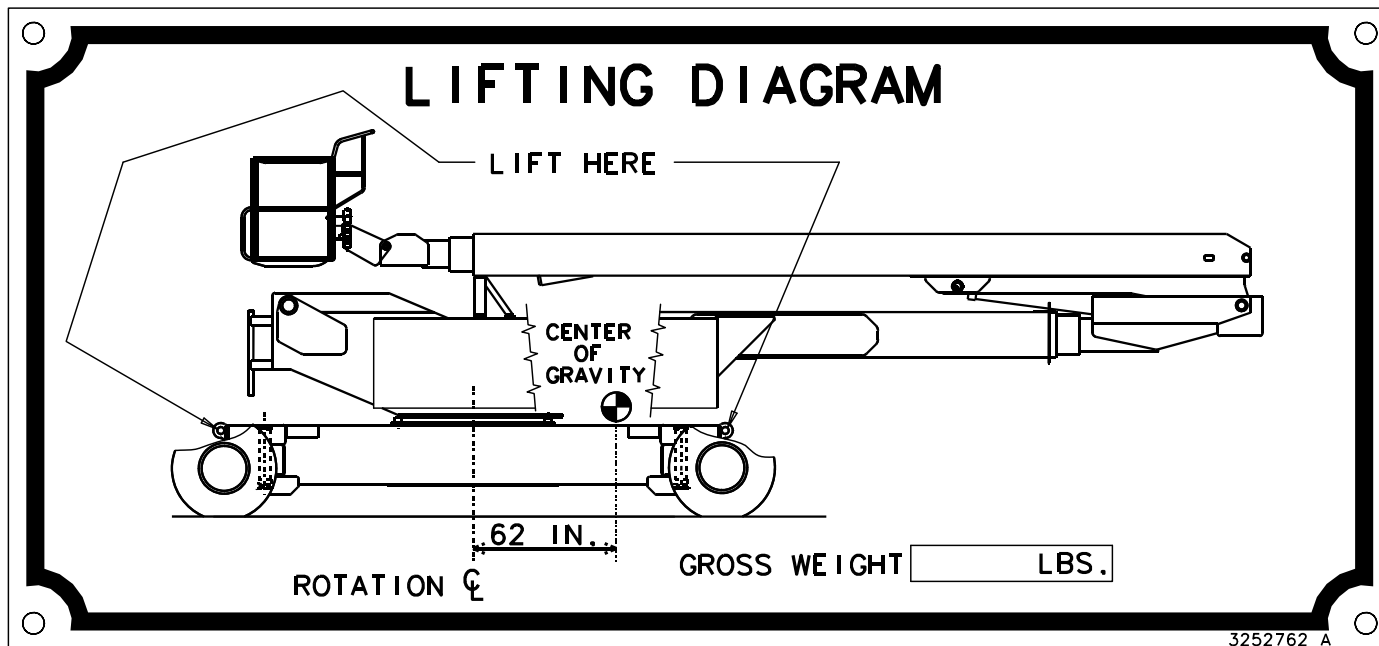

Figure 4-4. Lifting Diagram

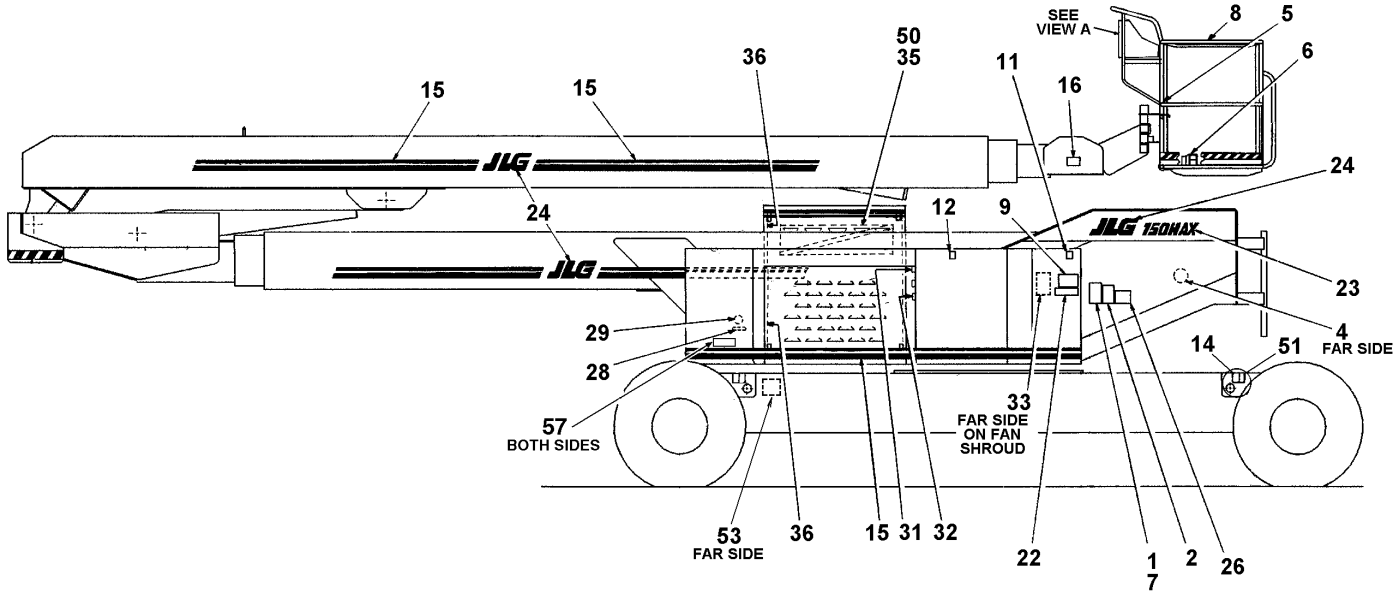

Figure 4-5. Decal Installation- Sheet 1 of 2

SECTION 4 - MACHINE OPERATION

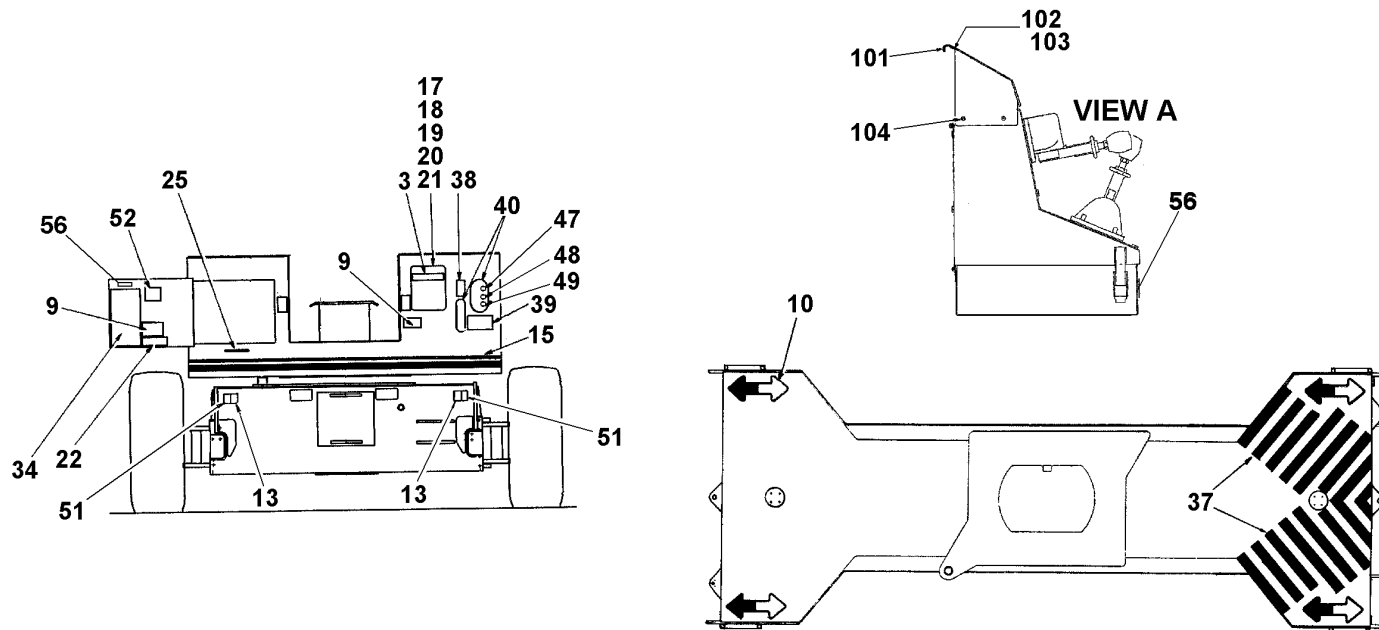

Figure 4-6. Decal Installation- Sheet 2 of 2

SECTION 4 - MACHINE OPERATION

Table 4-1. Decal Installation - Prior to S/N 0300103758

| Item # | ANSI 0257251-2 | Dutch 0252864-2 | French 0252079-2 | German 0252862-2 | Italian 0252863-2 | Spanish 0253267-2 | UK 0252078-4 |
|---------------|---------------------------|----------------------------|-----------------------------|-----------------------------|------------------------------|------------------------------|-------------------------|
| 1 | 1706948 | 3252523 | 3252523 | 3252523 | 3252523 | 3252523 | 3252523 |
| 2 | 1700584 | 1700584 | 1700584 | 1700584 | 1700584 | 1700584 | 1700584 |
| 3 | 1701509 | 1701509 | 1701509 | 1701509 | 1701509 | 1701509 | 1701509 |
| 4 | 3251813 | -- | -- | -- | -- | -- | -- |
| 5 | 1704277 | -- | -- | -- | -- | -- | -- |
| 6 | -- | 1703518 | 1693292 | 1693294 | 1701600 | 1701791 | -- |
| 7 | -- | -- | -- | -- | -- | -- | -- |
| 8 | 1702868 | -- | -- | -- | -- | -- | -- |
| 9 | 1703953 | -- | -- | -- | -- | -- | -- |
| 10 | 1701501 | 1701501 | 1701501 | 1701501 | 1701501 | 1701501 | 1701501 |
| 11 | -- | -- | -- | -- | -- | -- | -- |
| 12 | 1701504 | 1701504 | 1701504 | 1701504 | 1701504 | 1701504 | 1701504 |
| 13 | 1701500 | 1701500 | 1701500 | 1701500 | 1701500 | 1701500 | 1701500 |
| 14 | 1701499 | 1701499 | 1701499 | 1701499 | 1701499 | 1701499 | 1701499 |
| 15 | -- | 1701703 | 1701703 | 1701703 | 1701703 | 1701703 | 1701703 |
| 16 | 1703804 | -- | -- | -- | -- | -- | -- |
| 17 | -- | -- | -- | -- | -- | -- | -- |

SECTION 4 - MACHINE OPERATION

Table 4-1. Decal Installation - Prior to S/N 0300103758

| Item # | ANSI 0257251-2 | Dutch 0252864-2 | French 0252079-2 | German 0252862-2 | Italian 0252863-2 | Spanish 0253267-2 | UK 0252078-4 |
|--------|-------------------|--------------------|---------------------|---------------------|----------------------|----------------------|-----------------|
| 18 | -- | -- | -- | -- | -- | -- | -- |
| 19 | -- | -- | -- | -- | -- | -- | -- |
| 20 | -- | -- | -- | -- | -- | -- | -- |
| 21 | -- | -- | -- | -- | -- | -- | -- |
| 22 | 1703805 | -- | -- | -- | -- | -- | -- |
| 23 | 1701488 | 1701488 | 1701488 | 1701488 | 1701488 | 1701488 | 1701488 |
| 24 | 1700981 | 1700981 | 1700981 | 1700981 | 1700981 | 1700981 | 1700981 |
| 25 | 1700037 | 1701616 | 1701515 | 1693285 | 1701599 | 1701789 | 1700037 |
| 26 | 1702153 | -- | -- | -- | -- | -- | -- |
| 27 | -- | -- | -- | -- | -- | -- | -- |
| 28 | 3251243 | -- | -- | -- | -- | -- | -- |
| 29 | -- | -- | -- | -- | -- | -- | -- |
| 30 | -- | -- | -- | -- | -- | -- | -- |
| 31 | 1701502 | 1701502 | 1701502 | 1701502 | 1701502 | 1701502 | 1701502 |
| 32 | 1701503 | 1701503 | 1701503 | 1701503 | 1701503 | 1701503 | 1701503 |
| 33 | 1703162 | 1703162 | 1703162 | 1703162 | 1703162 | 1703162 | 1703162 |
| 34 | 1701527 | 1701527 | 1701527 | 1701527 | 1701527 | 1701527 | 1701527 |
| 35 | -- | -- | -- | -- | -- | -- | -- |

SECTION 4 - MACHINE OPERATION**Table 4-1. Decal Installation - Prior to S/N 0300103758**

| Item # | ANSI 0257251-2 | Dutch 0252864-2 | French 0252079-2 | German 0252862-2 | Italian 0252863-2 | Spanish 0253267-2 | UK 0252078-4 |
|---------------|---------------------------|----------------------------|-----------------------------|-----------------------------|------------------------------|------------------------------|-------------------------|
| 36 | -- | -- | -- | -- | -- | -- | -- |
| 37 | -- | -- | -- | -- | -- | -- | -- |
| 38 | 1701436 | 1701484 | 1701484 | 1701484 | 1701484 | 1701484 | 1701484 |
| 39 | 1701895 | 1701483 | 1701483 | 1701483 | 1701483 | 1701483 | 1701483 |
| 40 | -- | -- | -- | -- | -- | -- | -- |
| 41 | -- | 1701567 | 1701514 | 1701726 | 1701726 | 1701726 | 1701726 |
| 42 | -- | 1701518 | 1701518 | 1701518 | 1701518 | 1701518 | 1701518 |
| 43 | -- | 1701517 | 1701517 | 1701517 | 1701517 | 1701517 | 1701517 |
| 44 | 1703797 | -- | 1703511 | 1703508 | 1703514 | 1703509 | 1703513 |
| 45 | -- | 1701596 | 1703510 | 1703507 | 1703515 | 1703512 | 1703516 |
| 46 | -- | -- | -- | -- | -- | -- | -- |
| 47 | 1701428 | 1701428 | 1701428 | 1701428 | 1701428 | 1701428 | 1701428 |
| 48 | 1701427 | 1701427 | 1701427 | 1701427 | 1701427 | 1701427 | 1701427 |
| 49 | 1701426 | 1701426 | 1701426 | 1701426 | 1701426 | 1701426 | 1701426 |
| 50 | -- | -- | -- | -- | -- | -- | -- |
| 51 | 1702300 | 1702300 | 1702300 | 1702300 | 1702300 | 1702300 | 1702300 |
| 52 | 1705336 | -- | -- | -- | -- | -- | -- |
| 53 | 1702631 | 1702631 | 1702631 | 1702631 | 1702631 | 1702631 | 1702631 |

SECTION 4 - MACHINE OPERATION

Table 4-1. Decal Installation - Prior to S/N 0300103758

| Item # | ANSI 0257251-2 | Dutch 0252864-2 | French 0252079-2 | German 0252862-2 | Italian 0252863-2 | Spanish 0253267-2 | UK 0252078-4 |
|--------|-------------------|--------------------|---------------------|---------------------|----------------------|----------------------|-----------------|
| 54 | -- | 3252523 | 3252523 | 3252523 | 3252523 | 3252523 | 3252523 |
| 55 | 1703456 | 1703456 | 1703456 | 1703456 | 1703456 | 1703456 | 1703456 |
| 56 | 1704096 | -- | -- | -- | -- | -- | -- |
| 57 | 1707014 | -- | -- | -- | -- | -- | -- |
| 58 | -- | -- | -- | -- | -- | -- | -- |
| 59 | -- | -- | -- | -- | -- | -- | -- |

SECTION 4 - MACHINE OPERATION

Table 4-2. Decal Installation - S/N 0300103758 to Present

| Item # | ANSI 0257251-2 | Dutch 0252864-2 | French 0252079-2 | German 0252862-2 | Italian 0252863-2 | Spanish 0253267-2 | UK 0252078-4 |
|---------------|---------------------------|----------------------------|-----------------------------|-----------------------------|------------------------------|------------------------------|-------------------------|
| 1 | -- | 3252523 | 3252523 | 3252523 | 3252523 | 3252523 | 3252523 |
| 2 | 1700584 | 1700584 | 1700584 | 1700584 | 1700584 | 1700584 | 1700584 |
| 3 | 1701509 | 1701509 | 1701509 | 1701509 | 1701509 | 1701509 | 1701509 |
| 4 | 3251813 | -- | -- | -- | -- | -- | -- |
| 5 | 1704277 | -- | -- | -- | -- | -- | -- |
| 6 | -- | 1703518 | 1693292 | 1693294 | 1701600 | 1701791 | -- |
| 7 | -- | -- | -- | -- | -- | -- | -- |
| 8 | 1702868 | -- | -- | -- | -- | -- | -- |
| 9 | 1703953 | -- | -- | -- | -- | -- | -- |
| 10 | 1701501 | 1701501 | 1701501 | 1701501 | 1701501 | 1701501 | 1701501 |
| 11 | 1701505 | -- | -- | -- | -- | -- | -- |
| 12 | 1701504 | 1701504 | 1701504 | 1701504 | 1701504 | 1701504 | 1701504 |
| 13 | 1701500 | 1701500 | 1701500 | 1701500 | 1701500 | 1701500 | 1701500 |
| 14 | 1701499 | 1701499 | 1701499 | 1701499 | 1701499 | 1701499 | 1701499 |
| 15 | -- | 1701703 | 1701703 | 1701703 | 1701703 | 1701703 | 1701703 |
| 16 | 1703804 | -- | -- | -- | -- | -- | -- |
| 17 | -- | -- | -- | -- | -- | -- | -- |

SECTION 4 - MACHINE OPERATION

Table 4-2. Decal Installation - S/N 0300103758 to Present

| Item # | ANSI 0257251-2 | Dutch 0252864-2 | French 0252079-2 | German 0252862-2 | Italian 0252863-2 | Spanish 0253267-2 | UK 0252078-4 |
|--------|-------------------|--------------------|---------------------|---------------------|----------------------|----------------------|-----------------|
| 18 | -- | -- | -- | -- | -- | -- | -- |
| 19 | -- | -- | -- | -- | -- | -- | -- |
| 20 | -- | -- | -- | -- | -- | -- | -- |
| 21 | -- | -- | -- | -- | -- | -- | -- |
| 22 | 1703805 | -- | -- | -- | -- | -- | -- |
| 23 | 1701488 | 1701488 | 1701488 | 1701488 | 1701488 | 1701488 | 1701488 |
| 24 | 1700981 | 1700981 | 1700981 | 1700981 | 1700981 | 1700981 | 1700981 |
| 25 | 1700037 | 1701616 | 1701515 | 1693285 | 1701599 | 1701789 | 1700037 |
| 26 | 1702153 | -- | -- | -- | -- | -- | -- |
| 27 | -- | -- | -- | -- | -- | -- | -- |
| 28 | 3251243 | -- | -- | -- | -- | -- | -- |
| 29 | -- | -- | -- | -- | -- | -- | -- |
| 30 | -- | -- | -- | -- | -- | -- | -- |
| 31 | 1701502 | 1701502 | 1701502 | 1701502 | 1701502 | 1701502 | 1701502 |
| 32 | 1701503 | 1701503 | 1701503 | 1701503 | 1701503 | 1701503 | 1701503 |
| 33 | 1703162 | 1703162 | 1703162 | 1703162 | 1703162 | 1703162 | 1703162 |
| 34 | 1701527 | 1701527 | 1701527 | 1701527 | 1701527 | 1701527 | 1701527 |
| 35 | -- | -- | -- | -- | -- | -- | -- |

SECTION 4 - MACHINE OPERATION**Table 4-2. Decal Installation - S/N 0300103758 to Present**

| Item # | ANSI 0257251-2 | Dutch 0252864-2 | French 0252079-2 | German 0252862-2 | Italian 0252863-2 | Spanish 0253267-2 | UK 0252078-4 |
|---------------|---------------------------|----------------------------|-----------------------------|-----------------------------|------------------------------|------------------------------|-------------------------|
| 36 | -- | -- | -- | -- | -- | -- | -- |
| 37 | -- | -- | -- | -- | -- | -- | -- |
| 38 | 1701436 | 1701484 | 1701484 | 1701484 | 1701484 | 1701484 | 1701484 |
| 39 | 1701895 | 1701483 | 1701483 | 1701483 | 1701483 | 1701483 | 1701483 |
| 40 | -- | -- | -- | -- | -- | -- | -- |
| 41 | -- | 1701567 | 1701514 | 1701726 | 1701726 | 1701726 | 1701726 |
| 42 | -- | 1701518 | 1701518 | 1701518 | 1701518 | 1701518 | 1701518 |
| 43 | -- | 1701517 | 1701517 | 1701517 | 1701517 | 1701517 | 1701517 |
| 44 | 1703797 | -- | 1703511 | 1703508 | 1703514 | 1703509 | 1703513 |
| 45 | -- | 1701596 | 1703510 | 1703507 | 1703515 | 1703512 | 1703516 |
| 46 | -- | -- | -- | -- | -- | -- | -- |
| 47 | 1701428 | 1701428 | 1701428 | 1701428 | 1701428 | 1701428 | 1701428 |
| 48 | 1701427 | 1701427 | 1701427 | 1701427 | 1701427 | 1701427 | 1701427 |
| 49 | 1701426 | 1701426 | 1701426 | 1701426 | 1701426 | 1701426 | 1701426 |
| 50 | -- | -- | -- | -- | -- | -- | -- |
| 51 | 1702300 | 1702300 | 1702300 | 1702300 | 1702300 | 1702300 | 1702300 |
| 52 | 1705336 | -- | -- | -- | -- | -- | -- |
| 53 | -- | 1702631 | 1702631 | 1702631 | 1702631 | 1702631 | 1702631 |

SECTION 4 - MACHINE OPERATION

Table 4-2. Decal Installation - S/N 0300103758 to Present

| Item # | ANSI 0257251-2 | Dutch 0252864-2 | French 0252079-2 | German 0252862-2 | Italian 0252863-2 | Spanish 0253267-2 | UK 0252078-4 |
|---------------|---------------------------|----------------------------|-----------------------------|-----------------------------|------------------------------|------------------------------|-------------------------|
| 54 | -- | 3252523 | 3252523 | 3252523 | 3252523 | 3252523 | 3252523 |
| 55 | 1703456 | 1703456 | 1703456 | 1703456 | 1703456 | 1703456 | 1703456 |
| 56 | 1704096 | -- | -- | -- | -- | -- | -- |
| 57 | 1707014 | -- | -- | -- | -- | -- | -- |
| 58 | -- | -- | -- | -- | -- | -- | -- |
| 59 | -- | -- | -- | -- | -- | -- | -- |

SECTION 5. EMERGENCY PROCEDURES

5.1 GENERAL

This section explains the steps to be taken in case of an emergency situation while operating.

5.2 INCIDENT NOTIFICATION

JLG Industries, Inc. must be notified immediately of any incident involving a JLG product. Even if no injury or property damage is evident, the factory should be contacted by telephone and provided with all necessary details.

In USA:

JLG Phone: 877-JLG-SAFE (554-7233)
(8am till 4:45pm EST)

Outside USA:

240-420-2661

E-mail:

ProductSafety@JLG.com

Failure to notify the manufacturer of an incident involving a JLG Industries product within 48 hours of such an occurrence may void any warranty consideration on that particular machine.

NOTICE

FOLLOWING ANY ACCIDENT, THOROUGHLY INSPECT THE MACHINE AND TEST ALL FUNCTIONS FIRST FROM THE GROUND CONTROLS, THEN FROM THE PLATFORM CONTROLS. DO NOT LIFT ABOVE 10 FT. (3 M) UNTIL YOU ARE SURE THAT ALL DAMAGE HAS BEEN REPAIRED, IF REQUIRED, AND THAT ALL CONTROLS ARE OPERATING CORRECTLY.

5.3 EMERGENCY TOWING PROCEDURES

⚠ WARNING

RUNAWAY VEHICLE/MACHINE HAZARD. MACHINE HAS NO TOWING BRAKES. TOWING VEHICLE MUST BE ABLE TO CONTROL MACHINE AT ALL TIMES. ON-HIGHWAY TOWING NOT PERMITTED. FAILURE TO FOLLOW INSTRUCTIONS COULD CAUSE SERIOUS INJURY OR DEATH.

Towing the machine is prohibited, unless properly equipped. However, provisions for moving the machine, in case of a malfunction or power failure, have been incorporated. The following procedures are to be used **ONLY** for emergency movement to a suitable maintenance area.

1. Chock wheels securely.
2. Disengage drive hubs by reversing disconnect caps.

SECTION 5 - EMERGENCY PROCEDURES

3. Connect suitable equipment, remove chocks, and move machine.

After moving machine, complete the following procedures:

1. Position machine on a firm, level surface.
2. Chock wheels securely.
3. Engage drive hubs by reversing disconnect caps on hubs.
4. Remove chocks from wheels.

5.4 EMERGENCY CONTROLS AND THEIR LOCATIONS

Ignition/Emergency Stop Switch

This switch is a large red button located on the platform console panel and also on the ground control remote box. With the button pulled out, power is supplied to the start button. When the red button is depressed it will shut off power and immediately stop the machine. The corresponding button, ground or platform, must be pulled out in order for the machine to operate from the desired control station.

WARNING

CHECK MACHINE DAILY TO MAKE SURE IGNITION/EMERGENCY STOP BUTTON IS IN PLACE AND THAT GROUND CONTROL INSTRUCTIONS ARE IN PLACE AND LEGIBLE.

Ground Control Station

The Ground Control Station is located on the front right side of the turntable. The controls on this panel provide the means for overriding the platform controls and for controlling the platform level, platform rotate, tower boom lift, tower boom telescope, main boom lift, main boom telescope, swing, creep speed and activating auxiliary power from the ground. Place the station SELECT SWITCH in the GROUND position and operate the proper controller or control switch.

Auxiliary Power

A toggle-type auxiliary power control switch is located on the platform control station and another is located on the ground control station. Operation of either switch turns on the electrically driven auxiliary hydraulic pump. Auxiliary power should be used in case of failure of the main power plant. The auxiliary pump will operate tower lift up and down, main lift up and down, tower telescope in and out, main telescope in and out, swing left and right, platform rotate and platform level.

To activate auxiliary power from the platform:

1. Position PLATFORM/GROUND SELECT SWITCH to PLATFORM.
2. Position MASTER SWITCH to ON.
3. Depress and hold footswitch.
4. Operate appropriate control switch or controller for desired function and hold.
5. Position AUXILIARY POWER switch to ON and hold.
6. Release AUXILIARY POWER switch and appropriate control switch or controller and footswitch.
7. Position MASTER SWITCH to OFF.

To activate auxiliary power from the ground control station:

1. Position PLATFORM/GROUND SELECT SWITCH to GROUND.
2. Position MASTER SWITCH to ON.
3. Operate appropriate control switch or controller for desired function and hold.
4. Position AUXILIARY POWER switch to ON and hold.
5. Release AUXILIARY POWER switch and appropriate control switch or controller.

6. Position MASTER SWITCH to OFF.

Manual Descent and Retraction

The manual descent valves are used, in the event of total power failure, to retract the tower boom and lower the main boom using gravity. To operate the manual descent system, proceed as follows:

1. Remove manual descent pump handle from inside battery access door.
2. Open manual descent valves # 1 and # 2 by turning valve handles counterclockwise and close manual descent valve # 3 by turning valve handle clockwise.
3. Pump hydraulic hand pump until tight, or until Tower Telescope In and Main Lift Down begin retracting. To stop functions, open valve # 3.
4. Tower Telescope In and Main Lift Down can be operated independent of each other. To operate Tower Telescope In open valve # 1. To operate Main Lift Down open valve # 2.
5. When manual descent function has been completed, open all valves 1 full turn, then return pump handle to stowed position.

SECTION 5 - EMERGENCY PROCEDURES

5.5 EMERGENCY OPERATION

Use of Ground Controls

KNOW HOW TO USE THE GROUND CONTROLS IN AN EMERGENCY SITUATION.

Ground personnel must be thoroughly familiar with the machine operating characteristics and the ground control functions. Training should include operation of the machine, review and understanding of this section and hands-on operation of the controls in simulated emergencies.

Operator Unable to Control Machine

IF THE PLATFORM OPERATOR IS PINNED, TRAPPED OR UNABLE TO OPERATE OR CONTROL THE MACHINE:

⚠ WARNING

DO NOT OPERATE WITH PRIMARY POWER SOURCE (ENGINE) IF PERSONS ARE PINNED OR TRAPPED. USE AUXILIARY POWER INSTEAD.

1. Operate the machine from ground controls **ONLY** with the assistance of other personnel and equipment (cranes, overhead hoists, etc.) as may be required to safely remove the danger or emergency condition.

2. Other qualified personnel on the platform may use the platform controls with regular or auxiliary power. **DO NOT CONTINUE OPERATION IF CONTROLS DO NOT FUNCTION NORMALLY.**
3. Prior to removing platform occupants, cranes, forklift trucks or other equipment which may be available are to be used to stabilize motion of the machine in case machine controls are inadequate or malfunction when used.

Platform or Boom Caught Overhead

If the platform or boom becomes jammed or snagged in overhead structures or equipment, do not continue operation of the machine from either the platform or the ground until the operator and all personnel are safely moved to a secure location. Only then should an attempt be made to free the platform using any necessary equipment and personnel. Do not operate controls to cause one or more wheels to leave the ground.

Following any accident, thoroughly inspect the machine and test all functions first from the ground controls, then from the platform controls. Do not lift above 3 meters until you are secure that all damage has been repaired, if required, and that all controls are operating correctly.

SECTION 6. GENERAL SPECIFICATIONS & OPERATOR MAINTENANCE

6.1 INTRODUCTION

This section of the manual provides additional necessary information to the operator for proper operation and maintenance of this machine.

The maintenance portion of this section is intended as information to assist the machine operator to perform daily maintenance tasks only, and does not replace the more thorough Preventive Maintenance and Inspection Schedule included in the Service and Maintenance Manual.

Other Publications Available:

| | |
|--|---------|
| Service and Maintenance Manual - ANSI..... | 3120679 |
| Service and Maintenance Manual - CE | 3120817 |
| Illustrated Parts Manual - ANSI..... | 3120679 |
| Illustrated Parts Manual - CE | 3120812 |

6.2 OPERATING SPECIFICATIONS

Table 6-1. Operating Specifications

| | |
|--|------------------------|
| Maximum Work Load (Capacity) | |
| Unrestricted: | 500 lb (230 kg) |
| Restricted: | 1000 lb. (450 kg) |
| French Spec: | 585 lb (265 kg) |
| Maximum Travel Grade (Gradeability) with boom in stowed position. See Figure 4-3. | 30% |
| Maximum Travel Grade (Side Slope) with boom in stowed position. See Figure 4-3. | 5° |
| Machine Height w/main boom fully retracted and platform in normal position. | 14 ft. (4.3 m) |
| Machine Height w/main boom telescoped out and platform tilted to stow at minimum-height. | 10.5 ft. (3.2 m) |
| Turning Radius (outside) | |
| Axles Retracted: | 24 ft. 2 in. (7.4 m) |
| Axles Extended: | 27 ft. 2 in. (8.3 m) |
| Maximum Drive Speed: | 2.7 mph (4.3 kph) |
| Gross Machine Weight (Platform Empty) | 58,100 lb. (26,354 kg) |

SECTION 6 - GENERAL SPECIFICATIONS & OPERATOR MAINTENANCE

Capacities

Table 6-2. Capacities

| | |
|--------------------------------------|-------------------------------------|
| Fuel Tank | 68 gallons (257 liters) |
| Hydraulic Oil Tank | 124 gallons (469 liters) |
| Hydraulic System | 150 gallons (568 liters) |
| Drive Hub | 90 ounces (2.7 liters) |
| Swing Hub | 60 ounces (1.8 liters) |
| Engine Crankcase | 10.0 quarts (9.5 liters) w/o filter |
| Cooling System | |
| System - 21.4 quarts (20.2 liters) | 21.4 quarts (20.2 liters) |
| Engine - 7.4 quarts (7.0 liters) | 7.4 quarts (7.0 liters) |
| Radiator - 14.0 quarts (13.2 liters) | 14.0 quarts (13.2 liters) |

Engine

NOTE: RPM Tolerances are ± 100 .

Table 6-3. Cummins 4B3.9C

| | |
|------------|-------------------------------|
| Horsepower | 76 @ 2500 RPM, no load |
| Fuel | Diesel |
| Low RPM | 1800 |
| High RPM | 2500 |
| Alternator | 60 Amp, belt driven |
| Battery | 85 Amphour, 550 CCA, 12 volts |

Table 6-4. Cummins QSB4.5-NA

| | |
|--------------|--|
| Horsepower | 80 @ 2200 RPM, no load |
| Displacement | 275 in. ³ (4506 cm ³) |
| Fuel | Diesel |
| Low RPM | 1800 |
| High RPM | 2500 |
| Alternator | 60 Amp, belt driven |
| Battery | 85 Amphour, 550 CCA, 12 volts |

SECTION 6 - GENERAL SPECIFICATIONS & OPERATOR MAINTENANCE

Tires

Table 6-5. Tires

| Size | Type | Pressure | Ply |
|-------------|-------------|----------|-----|
| 445/65R22.5 | Foam-Filled | N/A | 22 |

Dimensional Data

Table 6-6. Dimensional Data

| | |
|---|--|
| Turning Radius (Outside) w/axles retracted w/axles extended | 24 ft. 2 in. (7.4 meters) 27 ft. 2 in. (8.3 meters) |
| Length Stowed w/main boom fully retracted and platform in normal position | 39 ft. 5 in. (12.0 meters) |
| w/main boom telescoped out and platform tilted to stow at minimum height | 41 ft. 7 in. (12.7 meters) |
| Machine Width w/axles retracted w/axles extended | 11 ft. 6 in. (3.5 meters) 18 ft. 0 in. (5.5 meters) |
| Wheelbase | 18 ft. 0 in. (5.5 meters) |

SECTION 6 - GENERAL SPECIFICATIONS & OPERATOR MAINTENANCE

Hydraulic Oil

Table 6-7. Hydraulic Oil

| Hydraulic System Operating Temperature Range | SAE Viscosity Grade |
|--|---------------------|
| 0° to +23° F (-18° to -5° C) | 10W |
| 0° to +210° F (-18° to +100° C) | 10W-20, 10W-30 |
| +50° to +210° F (+10° to +99° C) | 20W-20 |

NOTE: Hydraulic oils must have anti-wear qualities at least to API Service Classification GL-3, and sufficient chemical stability for mobile hydraulic system service. JLG Industries recommends Mobilfluid 424 hydraulic oil, which has an SAE viscosity index of 152.

NOTE: When temperatures remain consistently below 20 degrees F (-7 degrees C.), JLG Industries recommends the use of Mobil DTE13.

Aside from JLG recommendations, it is not advisable to mix oils of different brands or types, as they may not contain the same required additives or be of comparable viscosities. If use of hydraulic oil other than Mobilfluid 424 is desired, contact JLG Industries for proper recommendations.

Table 6-8. Mobilfluid 424 Specs

| | |
|-------------------------|---------------|
| SAE Grade | 10W30 |
| Gravity, API | 29.0 |
| Density, Lb/Gal. 60°F | 7.35 |
| Pour Point, Max | -46°F (-43°C) |
| Flash Point, Min. | 442°F (228°C) |
| Viscosity | |
| Brookfield, cP at -18°C | 2700 |
| at 40° C | 55 cSt |
| at 100° C | 9.3 cSt |
| Viscosity Index | 152 |

SECTION 6 - GENERAL SPECIFICATIONS & OPERATOR MAINTENANCE

Table 6-9. Mobil EAL 224 H Specs

| Type | Biodegradable Vegetable Oil |
|--|---|
| ISO Viscosity Grade | 32/46 |
| Specific Gravity | .922 |
| Pour Point, Max | -25°F (-32°C) |
| Flash Point, Min. | 428°F (220°C) |
| Weight | 7.64 lb. per gal. (0.9 kg per liter) |
| Viscosity | |
| at 104° F (40° C) | 37 cSt |
| at 212° F (100° C) | 8.4 cSt |
| Viscosity Index | 213 |
| Operating Temp | 0-180° F (-17 --162°C) |
| Note: Must be stored above 32° F (14° C) | |

Table 6-10. Mobil DTE 13M Specs

| Type | Petroleum Base |
|---------------------|----------------|
| ISO Viscosity Grade | 32 |
| Specific Gravity | .877 |
| Pour Point, Max | -40°F (-40°C) |
| Flash Point, Min. | 330°F (166°C) |
| Viscosity | |
| at 104° F (40° C) | 33 cSt |
| at 212° F (100° C) | 6.5 cSt |
| Viscosity Index | 140 |

SECTION 6 - GENERAL SPECIFICATIONS & OPERATOR MAINTENANCE

Table 6-11. Exxon Unavis HVI 26 Specs

| | |
|--|---------------|
| Specific Gravity | 32.1 |
| Pour Point | -76°F (-60°C) |
| Flash Point | 217°F (103°C) |
| Viscosity | |
| at 40° C | 25.8 cSt |
| at 100° C | 9.3 cSt |
| Viscosity Index | 376 |
| NOTE: <i>Mobil/Exxon recommends that this oil be checked on a yearly basis for viscosity.</i> | |

Critical Stability Weights

Table 6-12. Critical Stability Weights

| | LB. | KG. |
|-----------------------|------|------|
| Counterweight | 3285 | 1490 |
| Tire & Wheel Assembly | 1020 | 494 |
| Engine | 680 | 308 |
| 8 ft. Platform | 295 | 134 |

Serial Number Locations

For machine identification, a serial number plate is affixed to the machine. The plate is located on the left side of the turntable, just behind the fuel tank. If the serial number plate is missing,

the machine serial number is stamped on the left side of the frame, below the turntable bearing. In addition, the last five digits of the serial number are stamped on the top of the fly end of each of the tower boom and main boom sections.

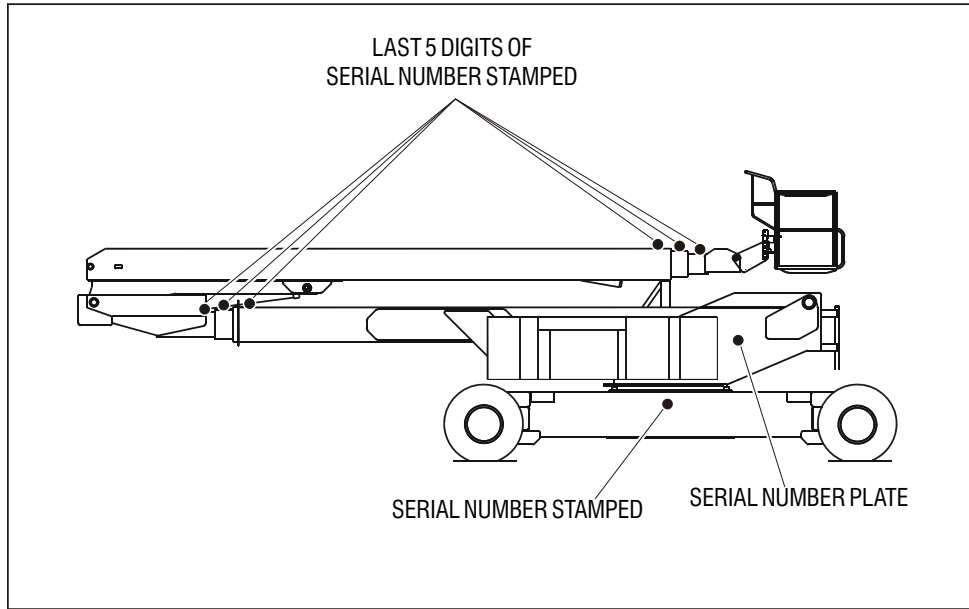

Figure 6-1. Serial Number Locations

SECTION 6 - GENERAL SPECIFICATIONS & OPERATOR MAINTENANCE

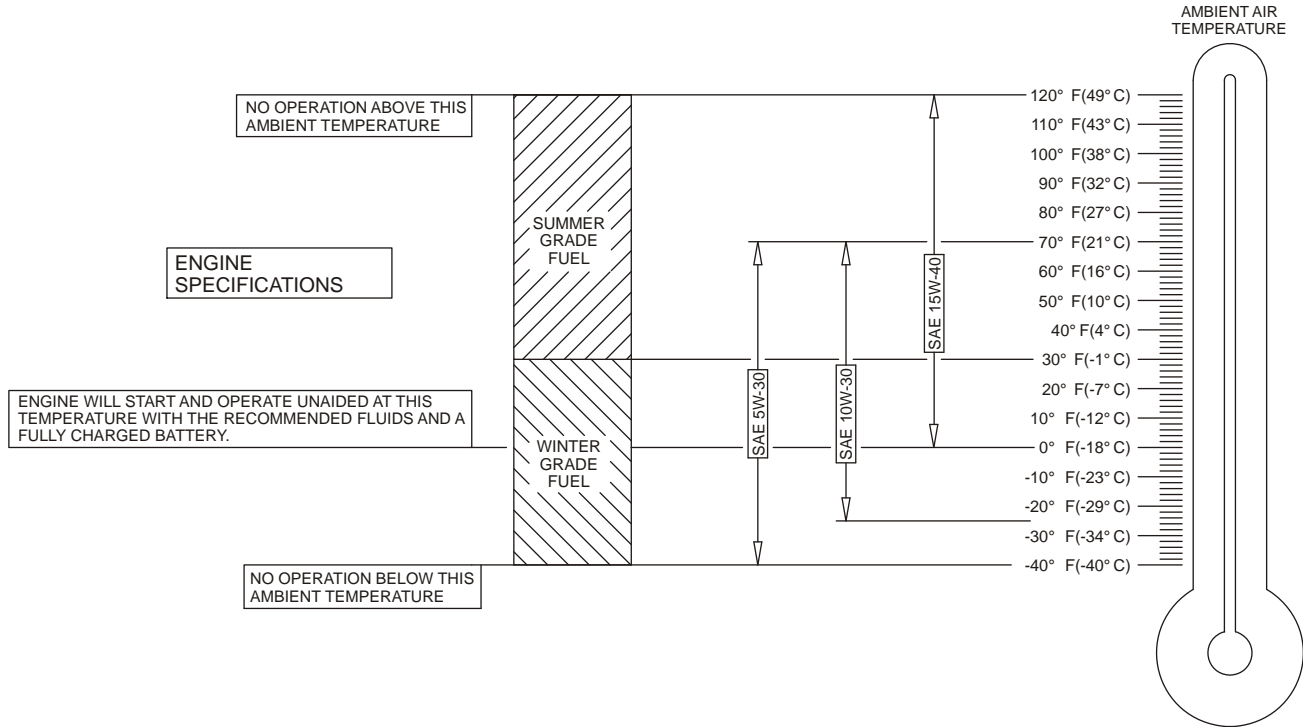

Figure 6-2. Engine Operating Temperature Specifications - Cummins - Sheet 1 of 2

SECTION 6 - GENERAL SPECIFICATIONS & OPERATOR MAINTENANCE

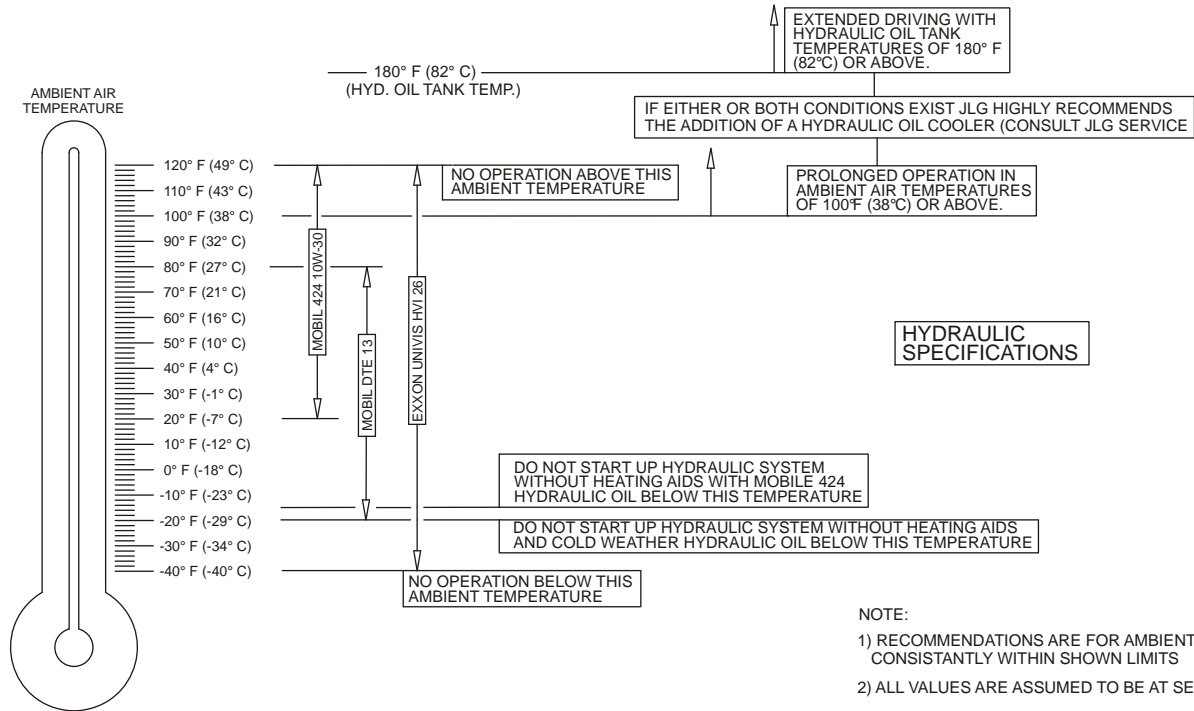

Figure 6-3. Engine Operating Temperature Specifications - Cummins - Sheet 2 of 2

SECTION 6 - GENERAL SPECIFICATIONS & OPERATOR MAINTENANCE

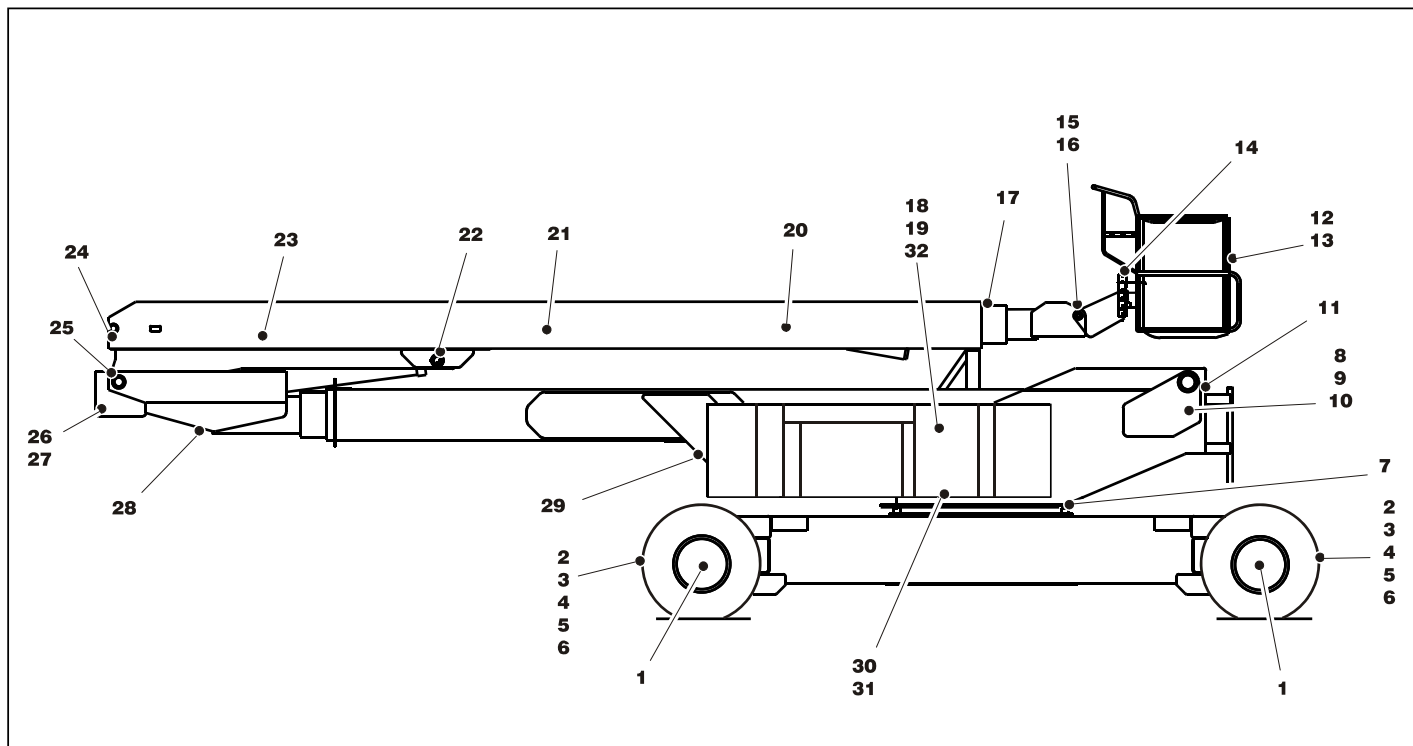

Figure 6-4. Operator Maintenance & Lubrication Diagram

6.3 OPERATOR MAINTENANCE

NOTE: The following numbers correspond to those in Figure 6-4., Operator Maintenance & Lubrication Diagram.

Table 6-13. Lubrication Specifications

| KEY | SPECIFICATIONS |
|------|---|
| MPG | Multipurpose Grease having a minimum dripping point of 350° F (177° C). Excellent water resistance and adhesive qualities, and being of extreme pressure type. (Timken OK 40 pounds minimum.) |
| EPGL | Extreme Pressure Gear Lube (oil) meeting API service classification GL-5 or MIL-Spec MIL-L-2105 |
| HO | Hydraulic Oil. API service classification GL-3, e.g. Mobilfluid 424. |
| EO | Engine (crankcase) Oil. Gas - API SF, SH, SG class, MIL-L-2104. Diesel - API CC/CD class, MIL-L-2104B/MIL-L-2104C. |

NOTICE

LUBRICATION INTERVALS ARE BASED ON MACHINE OPERATION UNDER NORMAL CONDITIONS. FOR MACHINES USED IN MULTI-SHIFT OPERATIONS AND/OR EXPOSED TO HOSTILE ENVIRONMENTS OR CONDITIONS, LUBRICATION FREQUENCIES MUST BE INCREASED ACCORDINGLY.

NOTE: It is recommended as a good practice to replace all filters at the same time.

1. Torque Hubs

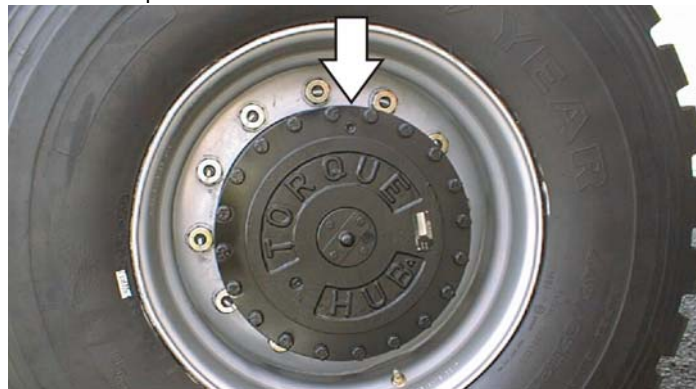

Lube Point(s) - 1 Fill Plug per hub

Capacity -

Lube - EPGL

Interval - Check oil level at side plug on hub weekly. Change after first 3 months or 150 hours then every 2 years or 1200 hours of operation.

Comments - Place Fill port at 12 o'clock position and pour lubricant into fill port until it just starts to flow out of check port when it's at the 3 o'clock position.

SECTION 6 - GENERAL SPECIFICATIONS & OPERATOR MAINTENANCE

2. Steer Spindles



Lube Point(s) - 4 Grease Fittings
Capacity - A/R
Lube - MPG
Interval - Every 3 months or 150 hrs of operation

3. Tie Rod Center Pivot Links

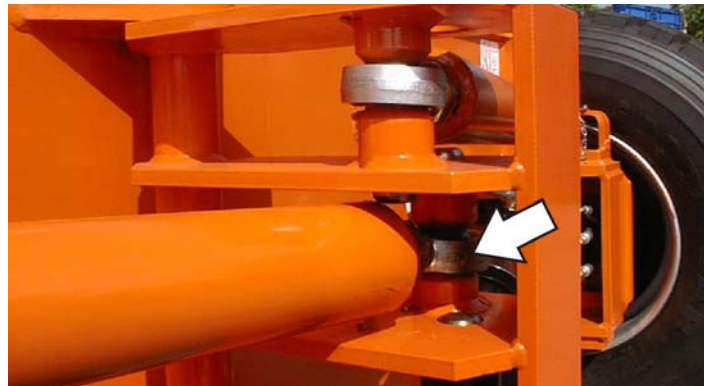

Lube Point(s) - 2 Grease Fittings
Capacity - A/R
Lube - MPG
Interval - Every 3 months or 150 hrs of operation

SECTION 6 - GENERAL SPECIFICATIONS & OPERATOR MAINTENANCE

4. Steer Cylinder Barrel Ends



Lube Point(s) - 2 Grease Fittings
Capacity - A/R
Lube - MPG
Interval - Every 3 months or 150 hrs of operation

5. Steer Cylinder Rod Ends



Lube Point(s) - 2 Grease Fittings
Capacity - A/R
Lube - MPG
Interval - Every 3 months or 150 hrs of operation

SECTION 6 - GENERAL SPECIFICATIONS & OPERATOR MAINTENANCE

6. Extending Axles



Lube Point(s) - N/A
Capacity - A/R
Lube - MPG
Interval - Every 3 months or 150 hrs of operation
Comments - Apply by brush

7. Swing Bearing Gear



Lube Point(s) - N/A
Capacity - A/R
Lube - MPG
Interval - Every 3 months or 150 hrs of operation
Comments - Apply by brush

SECTION 6 - GENERAL SPECIFICATIONS & OPERATOR MAINTENANCE

8. Lower Master Cylinder Barrel End



Lube Point(s) - 1 Grease Fitting
Capacity - A/R
Lube - MPG
Interval - Every 3 months or 150 hrs of operation
Comments - Remote Fitting on Left Rear of Turntable

9. Tower Boom Lift Cylinder Barrel End



Lube Point(s) - 1 Grease Fitting
Capacity - A/R
Lube - MPG
Interval - Every 3 months or 150 hrs of operation
Comments - Remote Fitting on Left Rear of Turntable

SECTION 6 - GENERAL SPECIFICATIONS & OPERATOR MAINTENANCE

10. Swing Bearing



Lube Point(s) - 2 Grease Fitting
Capacity - A/R
Lube - MPG
Interval - Every 3 months or 150 hrs of operation
Comments - Remote Fitting on Left Rear of Turntable

11. Lower Master Cylinder Rod End

Lube Point(s) - 1 Grease Fitting
Capacity - A/R
Lube - MPG
Interval - Every 3 months or 150 hrs of operation
Comments -

12. Platform Hinges



Lube Point(s) - 2 Grease Fittings
Capacity - A/R
Lube - MPG
Interval - Every 3 months or 150 hrs of operation

13. Platform Door Latch

Lube Point(s) - N/A
Capacity - A/R
Lube - EO
Interval - Every 3 months or 150 hrs of operation

SECTION 6 - GENERAL SPECIFICATIONS & OPERATOR MAINTENANCE

14. Platform Rotate Pivot/Rotator Worm Gear



Lube Point(s) - 2 Grease Fittings on pivot; 1 Grease Fitting on worm gear
Capacity - A/R
Lube - MPG
Interval - Every 3 months or 150 hrs of operation

15. Platform Level Links

Lube Point(s) - 3 Grease Fittings
Capacity - A/R
Lube - MPG
Interval - Every 3 months or 150 hrs of operation

SECTION 6 - GENERAL SPECIFICATIONS & OPERATOR MAINTENANCE

16. Level Cylinder Rod End



Lube Point(s) - 1 Grease Fitting
Capacity - A/R
Lube - MPG
Interval - Every 3 months or 150 hrs of operation

17. Level Cylinder Barrel End

Lube Point(s) - 1 Grease Fitting
Capacity - A/R
Lube - MPG
Interval - Every 3 months or 150 hrs of operation

18. Engine Crankcase



Lube Point(s) - Fill Cap/Drain Plug
Capacity - 10 quarts (9.5 L) w/o filter
Lube - EO
Comments - Check daily. Refer to Engine Manual for Change interval.

SECTION 6 - GENERAL SPECIFICATIONS & OPERATOR MAINTENANCE

19. Engine Oil Filter



Lube Point(s) - N/A

Lube - EO

Comments - Refer to Engine Manual for Change interval.

20. Main Boom Chains

Lube Point(s) - N/A

Capacity - N/A

Lube - Chain Lube

Interval - Every 2 years or 1200 hours of operation.

21. Main Boom Extend Chain Sheave

Lube Point(s) - 1 Grease Fitting

Capacity - A/R

Lube - MPG

Interval - Every 3 months or 150 hrs of operation

Comments - Align access holes in mid and fly boom

22. Main Boom Lift Cylinder



Lube Point(s) - 1 Grease Fitting

Capacity - A/R

Lube - MPG

Interval - Every 3 months or 150 hrs of operation

SECTION 6 - GENERAL SPECIFICATIONS & OPERATOR MAINTENANCE

23. Main Boom Retract Chain Sheave

Lube Point(s) - 1 Grease Fitting

Capacity - A/R

Lube - MPG

Interval - Every 3 months or 150 hrs of operation

Comments - Align with access hole in base boom.

24. Main Boom Pivot Pin



Lube Point(s) - 1 Grease Fitting

Capacity - A/R

Lube - MPG

Interval - Every 3 months or 150 hrs of operation

25. Tower Boom Pivot Pin

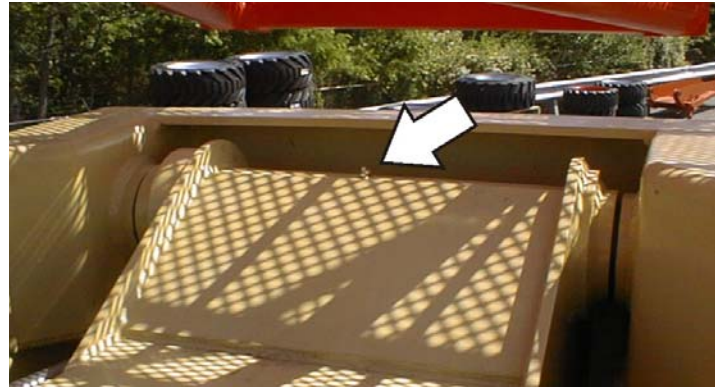

Lube Point(s) - 1 Grease Fitting

Capacity - A/R

Lube - MPG

Interval - Every 3 months or 150 hrs of operation

SECTION 6 - GENERAL SPECIFICATIONS & OPERATOR MAINTENANCE

26. Level Links



Lube Point(s) - 3 Grease Fitting
Capacity - A/R
Lube - MPG
Interval - Every 3 months or 150 hrs of operation
Comments -

27. Upper Master Cylinder Rod End



Lube Point(s) - 1 Grease Fitting
Capacity - A/R
Lube - MPG
Interval - Every 3 months or 150 hrs of operation
Comments -

SECTION 6 - GENERAL SPECIFICATIONS & OPERATOR MAINTENANCE

28. Upper Master Cylinder Barrel End



Lube Point(s) - 1 Grease Fitting
Capacity - A/R
Lube - MPG
Interval - Every 3 months or 150 hrs of operation
Comments -

29. Tower Boom Lift Cylinder Rod End

Lube Point(s) - 1 Grease Fitting
Capacity - A/R
Lube - MPG
Interval - Every 3 months or 150 hrs of operation
Comments -

30. Hydraulic Oil

Lube Point(s) - Fill Cap/Drain Plug
Capacity - A/R
Lube - HO
Interval - Check daily. Change every 2 years or 1200 hours
Comments - On new machines, those recently overhauled, or after changing hydraulic oil, operate all systems a minimum of two complete cycles and recheck oil level in reservoir.

31. Hydraulic Filter

Interval - Replace filter after first 50 hours of operation, then every 6 months or 300 hours thereafter.

SECTION 6 - GENERAL SPECIFICATIONS & OPERATOR MAINTENANCE

32. Air Filter



Lube Point(s) - Replaceable Element
Interval - Every 6 months or 300 hours of operation or as indicated by the condition indicator

6.4 TIRES & WHEELS

Tire Inflation

The air pressure for pneumatic tires must be equal to the air pressure that is stenciled on the side of the JLG product or rim decal for safe and proper operational characteristics.

Tire Damage

For pneumatic tires, JLG Industries, Inc. recommends that when any cut, rip, or tear is discovered that exposes sidewall or tread area cords in the tire, measures must be taken to remove the JLG product from service immediately. Arrangements must be made for replacement of the tire or tire assembly.

For polyurethane foam filled tires, JLG Industries, Inc. recommends that when any of the following are discovered, measures must be taken to remove the JLG product from service immediately and arrangements must be made for replacement of the tire or tire assembly.

- a smooth, even cut through the cord plies which exceeds 3 inches (7.5 cm) in total length
- any tears or rips (ragged edges) in the cord plies which exceeds 1 inch (2.5 cm) in any direction
- any punctures which exceed 1 inch in diameter

- any damage to the bead area cords of the tire

If a tire is damaged but is within the above noted criteria, the tire must be inspected on a daily basis to insure the damage has not propagated beyond the allowable criteria.

Tire Replacement

JLG recommends a replacement tire be the same size, ply and brand as originally installed on the machine. Please refer to the JLG Parts Manual for the part number of the approved tires for a particular machine model. If not using a JLG approved replacement tire, we recommend that replacement tires have the following characteristics:

- Equal or greater ply/load rating and size of original
- Tire tread contact width equal or greater than original
- Wheel diameter, width, and offset dimensions equal to the original
- Approved for the application by the tire manufacturer (including inflation pressure and maximum tire load)

Unless specifically approved by JLG Industries Inc. do not replace a foam filled or ballast filled tire assembly with a pneumatic tire. When selecting and installing a replacement tire, ensure that all tires are inflated to the pressure recommended

by JLG. Due to size variations between tire brands, both tires on the same axle should be the same.

Wheel Replacement

The rims installed on each product model have been designed for stability requirements which consist of track width, tire pressure, and load capacity. Size changes such as rim width, center piece location, larger or smaller diameter, etc., without written factory recommendations, may result in an unsafe condition regarding stability.

Wheel Installation

It is extremely important to apply and maintain proper wheel mounting torque.



WHEEL NUTS MUST BE INSTALLED AND MAINTAINED AT THE PROPER TORQUE TO PREVENT LOOSE WHEELS, BROKEN STUDS, AND POSSIBLE DANGEROUS SEPARATION OF WHEEL FROM THE AXLE. BE SURE TO USE ONLY THE NUTS MATCHED TO THE CONE ANGLE OF THE WHEEL.

Tighten the lug nuts to the proper torque to prevent wheels from coming loose. Use a torque wrench to tighten the fasteners. If you do not have a torque wrench, tighten the fasteners with a lug wrench, then immediately have a service garage or dealer tighten the lug nuts to the proper torque. Over-tightening will result in breaking the studs or permanently deforming the mounting stud holes in the wheels. The proper procedure for attaching wheels is as follows:

1. Start all nuts by hand to prevent cross threading. DO NOT use a lubricant on threads or nuts.

SECTION 6 - GENERAL SPECIFICATIONS & OPERATOR MAINTENANCE

2. Tighten nuts in the following sequence:

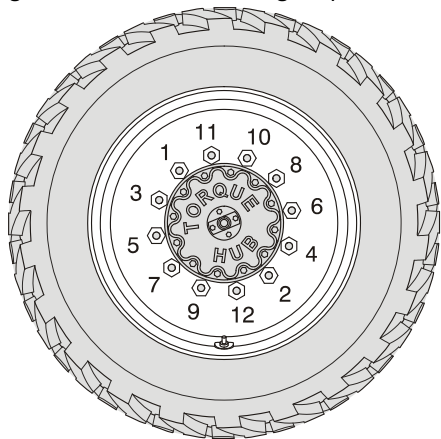

3. The tightening of the nuts should be done in stages. Following the recommended sequence, tighten nuts per wheel torque chart.

Table 6-14. Wheel Torque Chart

| TORQUE SEQUENCE | | |
|------------------------|--------------------------|--------------------------|
| 1st Stage | 2nd Stage | 3rd Stage |
| 70 ft. lbs. (95 Nm) | 170 ft. lbs. (225 Nm) | 300 ft. lbs. (405 Nm) |

4. Wheel nuts should be torqued after first 50 hours of operation and after each wheel removal. Check torque every 3 months or 150 hours of operation.

6.5 SUPPLEMENTAL INFORMATION

The following information is provided in accordance with the requirements of the European Machinery Directive 2006/42/EC and is only applicable to CE machines.

For electric powered machines, the equivalent continuous A-Weighted sound pressure level at the work platform is less than 70dB(A)

For combustion engine powered machines, guaranteed Sound Power Level (LWA) per European Directive 2000/14/EC (Noise Emission in the Environment by Equipment for Use Outdoors) based on test methods in accordance with Annex III, Part B, Method 1 and 0 of the directive, is 112 dB.

The vibration total value to which the hand-arm system is subjected does not exceed $2,5 \text{ m/s}^2$. The highest root mean square value of weighted acceleration to which the whole body is subjected does not exceed $0,5 \text{ m/s}^2$.



An Oshkosh Corporation Company

TRANSFER OF OWNERSHIP

To Product Owner:

If you now own but ARE NOT the original purchaser of the product covered by this manual, we would like to know who you are. For the purpose of receiving safety-related bulletins, it is very important to keep JLG Industries, Inc. updated with the current ownership of all JLG products. JLG maintains owner information for each JLG product and uses this information in cases where owner notification is necessary.

Please use this form to provide JLG with updated information with regard to the current ownership of JLG products. Please return completed form to the JLG Product Safety & Reliability Department via facsimile or mail to address as specified below.

Thank You,

Product Safety & Reliability Department
JLG Industries, Inc.

13224 Fountainhead Plaza
Hagerstown, MD 21742
USA

Telephone: +1-717-485-6591
Fax: +1-301-745-3713

NOTE: Leased or rented units should not be included on this form.

Mfg. Model: _____

Serial Number: _____

Previous Owner: _____

Address: _____

Country: _____ Telephone: (____) _____

Date of Transfer: _____

Current Owner: _____

Address: _____

Country: _____ Telephone: (____) _____

Who in your organization should we notify?

Name: _____

Title: _____



WARNING:



The engine exhaust from this product contains chemicals known to the State of California to cause cancer, birth defects, or other reproductive harm.

1702961

PROPOSITION 65 WARNING

- **Battery posts, terminals and related accessories contain lead and lead compounds, chemicals known to the State of California to cause cancer and reproductive harm.**
- **Batteries also contain other chemicals known to the State of California to cause cancer.**
- **Wash hands after handling.**



An Oshkosh Corporation Company

Corporate Office
JLG Industries, Inc.
1 JLG Drive
McConnellsburg PA. 17233-9533
USA

(717) 485-5161

(717) 485-6417



3121213

JLG Worldwide Locations

JLG Industries (Australia)
P.O. Box 5119
11 Bolwarra Road
Port Macquarie
N.S.W. 2444
Australia

+61 2 65 811111

+61 2 65813058

JLG Latino Americana Ltda.
Rua Eng. Carlos Stevenson,
80-Suite 71
13092-310 Campinas-SP
Brazil

+55 19 3295 0407

+55 19 3295 1025

JLG Industries (UK) Ltd
Bentley House
Bentley Avenue
Middleton
Greater Manchester
M24 2GP - England

+44 (0)161 654 1000

+44 (0)161 654 1001

JLG France SAS
Z.I. de Baulieu
47400 Fauillet
France

+33 (0)5 53 88 31 70

+33 (0)5 53 88 31 79

JLG Deutschland GmbH
Max-Planck-Str. 21
D - 27721 Ritterhude - Ihlpohl
Germany

+49 (0)421 69 350 20

+49 (0)421 69 350 45

JLG Equipment Services Ltd.
Rm 1107 Landmark North
39 Lung Sum Avenue
Sheung Shui N. T.
Hong Kong

(852) 2639 5783

(852) 2639 5797

JLG Industries (Italia) s.r.l.
Via Po. 22
20010 Pregnana Milanese - MI
Italy

+39 029 359 5210

+39 029 359 5845

Oshkosh-JLG Singapore Technology
Equipment Pte Ltd
29 Tuas Ave 4,
Jurong Industrial Estate
Singapore, 639379

+65-6591 9030

+65-6591 9031

Plataformas Elevadoras
JLG Iberica, S.L.
Trapadella, 2
P.I. Castellbisbal Sur
08755 Castellbisbal, Barcelona
Spain

+34 93 772 4700

+34 93 771 1762

JLG Sverige AB
Enkopingsvagen 150
Box 704
SE - 176 27 Jarfalla
Sweden

+46 (0)850 659 500

+46 (0)850 659 534